

SERVICE MANUAL LA-2 CHASSIS

<u>MODEL</u>	<u>COMMANDER</u>	<u>DEST.</u>	<u>CHASSIS NO.</u>	<u>MODEL</u>	<u>COMMANDER</u>	<u>DEST.</u>	<u>CHASSIS NO.</u>
<i>KF-42WE610</i>	<i>RM-Y913</i>	<i>US</i>					
<i>KF-42WE610</i>	<i>RM-Y913</i>	<i>Canadian</i>					
<i>KF-50WE610</i>	<i>RM-Y913</i>	<i>US</i>					
<i>KF-50WE610</i>	<i>RM-Y913</i>	<i>Canadian</i>					
<i>KF-60WE610</i>	<i>RM-Y913</i>	<i>US</i>					
<i>KF-60WE610</i>	<i>RM-Y913</i>	<i>Canadian</i>					

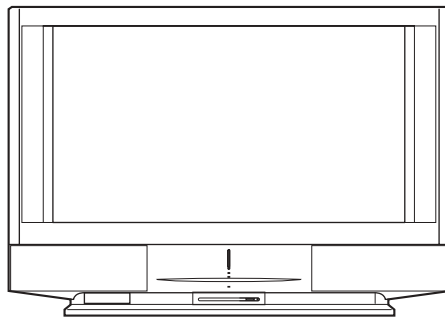

KF-42WE610/50WE610/60WE610



RM-Y913

LCD PROJECTION TV

SONY®

Specifications

Projection System	3 LCD Panels, 1 lens projection system	
LCD Panel	0.87 inch TFT LCD panel Approx. 3.28 million dots (1,092,168 pixels)	
Projection Lens	High Performance, large diameter hybrid lens F2.4	
Antenna	75 ohm external terminal for VHF/UHF	
Lamp	UHP lamp, 100W XL-2100U	
Television System	NTSC, American TV Standard	
Screen Size (measured diagonally)	KF-42WE610: 42 inches, KF-50WE610: 50 inches, KF-60WE610: 60 inches	
Channel Coverage		
VHF	2-13	
UHF	14-69	
CATV	1-125	
Power Requirements	120V, 60 Hz	
Number of Inputs/Outputs		
DVI-HDTV	1 terminal, 3.3 V T.M.D.S., 50 ohms The DVI-HDTV input terminal is compliant with the EIA-861 standard and is not intended for use with personal computers.	
Video (IN)	4	1 Vp-p, 75 ohms unbalanced, sync negative
S Video (IN)	4	Y: 1 Vp-p, 75 ohms unbalanced, sync negative C: 0.286 Vp-p (Burst signal), 75 ohms
Audio (IN)	6	500 mVrms (100% modulation) Impedance: 47 kilohms
AUDIO (VAR/FIX)	1	500 mVrms at the maximum volume setting (Variable) 500 mVrms (Fixed) Impedance (output): 2 kilohms
CONTROL S (IN/OUT)	1	minijacks
Component Video Input	2 (Y, P _B , P _R)	Y: 1.0 Vp-p, 75 ohms unbalanced, sync negative P _B : 0.7 Vp-p, 75 ohms P _R : 0.7 Vp-p, 75 ohms
RF Inputs	2	
Converter	1	
Speaker Output	5W (L), 5W (R), 20W (Woofer)	
Dimensions (W ◊ H ◊ D)	KF-42WE610: 1,201 x 819 x 371 mm (47 1/4 x 32 1/4 x 14 1/2 inches) KF-50WE610: 1,377 x 928 x 452 mm (54 1/4 x 36 1/2 x 17 3/4 inches) KF-60WE610: 1,619 x 1,067 x 541 mm (63 3/4 x 42 x 21 1/4 inches)	
Mass	KF-42WE610: 32 Kg (70 lb 12 oz) KF-50WE610: 39.5 kg (87 lb 1 oz), KF-60WE610: 49.5 kg (109 lb 2 oz)	
Power Consumption		
In Use	210 W	
In Standby	Under 1 W	

Supplied Accessories	
Remote Control	RM-Y913
AA Batteries	2 supplied for remote control
Cleaning Cloth	1
Optional Accessories	
TV Stand	SU-GW1 (for KF-50/60WE610), SU-GW2 (for KF-42WE610)
Lamp	XL-2100U
AV Cable	VC-810S/820S/830S
Control S Cable	RK-G69
Component Video Cable	VMC-10/30
AV Receiver	STR series or equivalent
Memory Stick media	8MB (MSA-8A), 16MB (MSA-16A), 32MB (MSA-32A), 64MB (MSA-64A), 128MB (MSA-128A)

Design and specifications are subject to change without notice.

SAFETY CHECK-OUT

(US model only)

After correcting the original service problem, perform the following safety checks before releasing the set to the customer:

1. Check the area of your repair for unsoldered or poorly-soldered connections. Check the entire board surface for solder splashes and bridges.
2. Check the interboard wiring to ensure that no wires are "pinched" or contact high-wattage resistors.
3. Check that all control knobs, shields, covers, ground straps, and mounting hardware have been replaced. Be absolutely certain that you have replaced all the insulators.
4. Look for unauthorized replacement parts, particularly transistors, that were installed during a previous repair. Point them out to the customer and recommend their replacement.
5. Look for parts which, through functioning, show obvious signs of deterioration. Point them out to the customer and recommend their replacement.
6. Check the line cords for cracks and abrasion. Recommend the replacement of any such line cord to the customer.
7. Check the condition of the monopole antenna (if any). Make sure the end is not broken off, and has the plastic cap on it. Point out the danger of impalement on a broken antenna to the customer, and recommend the antenna's replacement.
8. Check the B+ and HV to see they are at the values specified. Make sure your instruments are accurate; be suspicious of your HV meter if sets always have low HV.
9. Check the antenna terminals, metal trim, "metallized" knobs, screws, and all other exposed metal parts for AC leakage. Check leakage as described below.

LEAKAGE TEST

The AC leakage from any exposed metal part to earth ground and from all exposed metal parts to any exposed metal part having a return to chassis, must not exceed 0.5mA (500 microampers). Leakage current can be measured by any one of three methods.

1. A commercial leakage tester, such as the Simpson 229 or RCA WT-540A. Follow the manufacturers' instructions to use these instruments.
2. A battery-operated AC milliammeter. The Data Precision 245 digital multimeter is suitable for this job.
3. Measuring the voltage drop across a resistor by means of a VOM or battery-operated AC voltmeter. The "limit" indication is 0.75V, so analog meters must have an accurate low-voltage scale. The Simpson 250 and Sanwa SH-63Trd are examples of a passive VOM that is suitable. Nearly all battery-operated digital multimeters that have a 2V AC range are suitable. (See Fig. A)

HOW TO FIND A GOOD EARTH GROUND

A cold-water pipe is guaranteed earth ground; the cover-plate retaining screw on most AC outlet boxes is also at earth ground. If the retaining screw is to be used as your earth-ground, verify that it is at ground by measuring the resistance between it and a cold-water pipe with an ohmmeter. The reading should be zero ohms. If a cold-water pipe is not accessible, connect a 60-100 watt trouble light (not a neon lamp) between the hot side of the receptacle and the retaining screw. Try both slots, if necessary, to locate the hot side of the line, the lamp should light at normal brilliance if the screw is at ground potential. (See Fig. B)

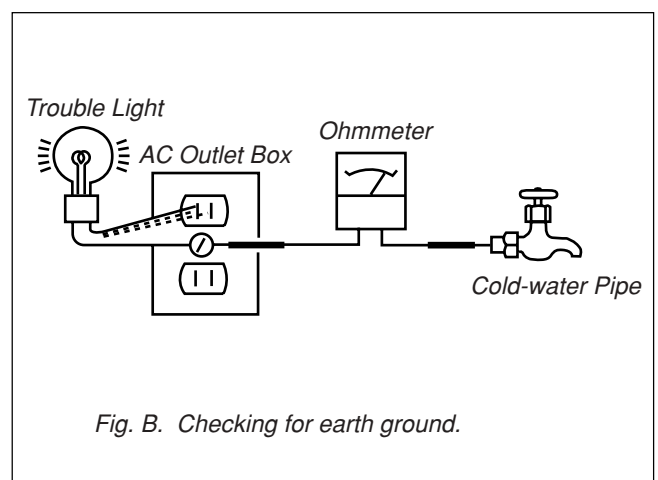
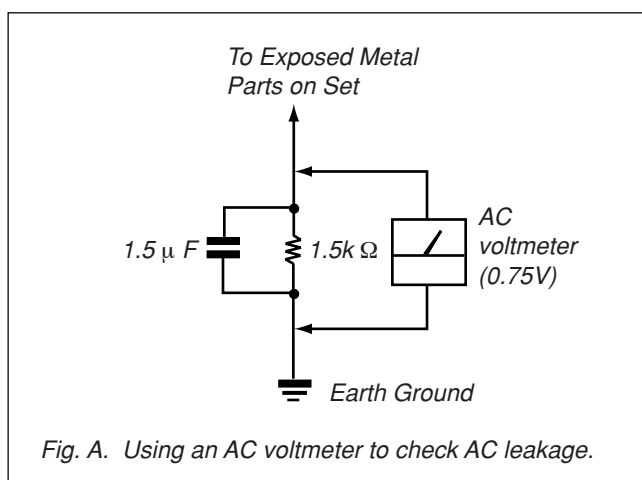

CAUTION

These servicing instructions are for use by qualified service personnel only.

To reduce the risk of electric shock, do not perform any servicing other than that contained in the operating instructions unless you are qualified to do so.

WARNING!!

AN ISOLATION TRANSFORMER SHOULD BE USED DURING ANY SERVICE TO AVOID POSSIBLE SHOCK HAZARD, BECAUSE OF LIVE CHASSIS. THE CHASSIS OF THIS RECEIVER IS DIRECTLY CONNECTED TO THE AC POWER LINE.

SAFETY-RELATED COMPONENT WARNING!!

COMPONENTS IDENTIFIED BY SHADING AND MARK \triangle ON THE SCHEMATIC DIAGRAMS, EXPLODED VIEWS AND IN THE PARTS LIST ARE CRITICAL TO SAFE OPERATION. REPLACE THESE COMPONENTS WITH SONY PARTS WHOSE PART NUMBERS APPEAR AS SHOWN IN THIS MANUAL OR IN SUPPLEMENTS PUBLISHED BY SONY. CIRCUIT ADJUSTMENTS THAT ARE CRITICAL TO SAFE OPERATION ARE IDENTIFIED IN THIS MANUAL. FOLLOW THESE PROCEDURES WHENEVER CRITICAL COMPONENTS ARE REPLACED OR IMPROPER OPERATION IS SUSPECTED.

ATTENTION!!

AFIN D'EVITER TOUT RISQUE DELECTROCUTION PROVENANT D'UN CHÂSSIS SOUS TENSION, UN TRANSFORMATEUR D'ISOLEMENT DOIT ETRE UTILISÉ LORS DE TOUT DEPANNAGE.

LE CHÂSSIS DE CE RECEPTEUR EST DIRECTEMENT RACCORDÉ À L'ALIMENTATION SECTEUR.

ATTENTION AUX COMPOSANTS RELATIFS À LA SÉCURITÉ!!

LES COMPOSANTS IDENTIFIÉS PAR UNE FRAME ET PAR UNE MAPQUE \triangle SUR LES SCHÉMAS DE PRINCIPE, LES VUES EXPLOSÉES ET LES LISTES DE PIÈCES SONT D'UNE IMPORTANCE CRITIQUE POUR LA SÉCURITÉ DU FONCTIONNEMENT. NE LES REMPLACER QUE PAR DES COMPOSANTS SONY DONT LE NUMÉRO DE PIÈCE EST INDIQUÉ DANS LE PRÉSENT MANUEL OU DANS DES SUPPLÉMENTS PUBLIÉS PAR SONY. LES RÉGLAGES DE CIRCUIT DONT L'IMPORTANCE EST CRITIQUE POUR LA SÉCURITÉ DU FONCTIONNEMENT SONT IDENTIFIÉS DANS LE PRÉSENT MANUEL. SUIVRE CES PROCÉDURES LORS DE CHAQUE REMPLACEMENT DE COMPOSANTS CRITIQUES, OU LORSQU'UN MAUVAIS FONCTIONNEMENT SUSPECTÉ.

TABLE OF CONTENTS

<u>Section</u>	<u>Title</u>	<u>Page</u>	<u>Section</u>	<u>Title</u>	<u>Page</u>
1. SELF DIAGNOSIS FUNCTION		8	4-4.	Schematic Diagrams	99
			(1)	Schematic Diagram of A (1/4) Board	100
			(2)	Schematic Diagram of A (2/4) Board	101
			(3)	Schematic Diagram of A (3/4) Board	102
			(4)	Schematic Diagram of A (4/4) Board	103
			(5)	Schematic Diagram of AU (1/2) Board	104
			(6)	Schematic Diagram of AU (2/2) Board	105
			(7)	Schematic Diagram of F Board	106
			(8)	Schematic Diagram of G1 Board	107
			(9)	Schematic Diagram of H1, H2 Board	108
			(10)	Schematic Diagram of H3 Board	109
			(11)	Schematic Diagram of HM Board	110
			(12)	Schematic Diagram of T Board	111
			(13)	Schematic Diagram of U (1/3) Board	112
			(14)	Schematic Diagram of U (2/3) Board	113
			(15)	Schematic Diagram of U (3/3) Board	114
			(16)	Schematic Diagram of UD (1/2) Board	115
			(17)	Schematic Diagram of UD (2/2) Board	116
			4-5.	Printed Wiring Boards	117
				• A Board (Side A)	117
				• A Board (Side B)	118
				• AU Board	119
				• F Board	120
				• G1 Board (Side A)	121
				• G1 Board (Side B)	122
				• H1 Board	123
				• H2 Board	124
				• H3 Board	125
				• HM Board	126
				• T Board	127
				• U Board (Side A)	128
				• U Board (Side B)	129
				• UD Board	130
			4-6	IC Block Diagrams	131
			4-7	Semiconductors	132
2. DISASSEMBLY			5. EXPLODED VIEWS		
2-1.	Rear Cover	12	5-1.	KF-42WE610/50WE610	
2-2.	Center Pillar	12		Screen Mirror Block Section	134
2-3.	Service Position	12	5-2.	KF-60WE610 Screen Mirror Block Section	135
2-4.	Chassis Assembly, Optical Unit Block, D.C.Fan	13	5-3.	Bottom Block	136
2-5.	UD Board, RF Antenna Switch	13	5-4.	Chassis-1	137
2-6.	U Board	13	5-5.	Chassis-2	138
2-7.	F and G1 Boards	14	5-4.	Optical Unit Block	139
2-8.	DIC Block, AU and C2 Boards	14			
2-9.	A Board	15			
2-10.	Power Supply Block	15			
2-11.	T Board	15			
2-12.	H3 Board (42WE610)	15			
2-13.	Front Cover Assembly	16			
2-14.	HM and H3 Boards (50WE610/60WE610)	16			
2-15.	H2 Board	17			
2-16.	HM Board (42WE610)	17			
2-17.	Screen Mirror Block Assembly	18			
2-18.	H1 Board	18			
3. ELECTRICAL ADJUSTMENTS					
3-1.	Electrical Adjustment by Remote Commander	19			
3-1-1.	Method of Setting the Service Adjustment Mode	19			
3-1-2.	Service Mode Adjustment	19			
3-1-3.	Memory Write Confirmation Method	19			
3-1-4.	Adjusting Buttons and Indicator	19			
3-1-5.	Service Mode List	21			
3-2.	Sub Color/Sub Hue Adjustment	90			
4. DIAGRAMS					
4-1.	Block Diagram (1)	91			
	Block Diagram (2)	92			
	Block Diagram (3)	93			
	Block Diagram (4)	94			
	Block Diagram (5)	95			
	Block Diagram (6)	96			
	Block Diagram (7)	97			
4-2.	Frame Schematic Diagram	98			
4-3.	Circuit Boards Location	99			

<u>Section</u>	<u>Title</u>	<u>Page</u>
6. ELECTRICAL PARTS LIST		140
	• A Board	140
	• AU Board	144
	• F Board	145
	• G1 Board	146
	• H1 Board	148
	• H2 Board	148
	• H3 Board	149
	• HM Board	149
	• T Board	150
	• U Board	150
	• UD Board	154

SECTION 1**SELF DIAGNOSIS FUNCTION****1. Summary of Self-Diagnosis Function**

- This device includes a self-diagnosis function.
- In case of abnormalities, the POWER/STANDBY indicator automatically blinks. It is possible to predict the abnormality location by the number of blinks. The Instruction Manual describes blinking of the POWER/STANDBY indicator.
- If the symptom is not reproduced sometimes in case of a malfunction, there is recording of whether a malfunction was generated or not. Operate the remote command to confirm the matter on the screen and to predict the location of the abnormality.

2. Diagnosis Items and Prediction of Malfunction Location

- When a malfunction occurs the POWER/STANDBY indicator only blinks for one of the following diagnosis items. In case of two or more malfunctions, the item which first occurred blinks. If the malfunctions occurred simultaneously, the item with the lower blink count blinks first.
- The screen display displays the results regarding all the diagnosis items listed below. The display "0" means that no malfunctions occurred.

Diagnosis Item	Number of times POWER/STANDBY indicator blinks	Probable Cause Location	Defected symptoms
Power does not turn on	0	- Power cord is not plugged in. - Fuse is burned out. (F1901:F board)	- Power does not come on. - No power is supplied to the unit. - AC power supply is faulty.
Lamp cover error	3 times	- Lamp cover is not attached securely.	- No picture/No sound
Fan stopped	4 times	- Fan1 or Fan2 or Fan3 power is not supplied.(A board) - Fan connector is not attached securely.	- No picture/No sound
Temp error	4 times	- Temperature is high. - IIC-E line connector (CN8023:A board,CN44:H3 board) is not attached securely.	- No picture/No sound
Lamp driver error	5 times	- Lamp driver is faulty.	- No picture/No sound
+B OVP error	6 times	- +17V is not supplied.(G1 board)	- No picture/No sound
Audio error	7 times	- Audio line is shorted.(A,G1 board) - IC8504(A board) or IC4704(AU board) is faulty. - PS1601 or 1602 is opened.(G1 board)	- No picture/No sound
D-OVP error	8 times	- +3.3V or +2.5V or +1.8V is over voltage.(G3 board)	- No picture/No sound
Lamp error	LAMP-LED flashes	- Lamp for the light source burns out.	- No picture/No sound

3. Blinking count display of POWER/STANDBY indicator

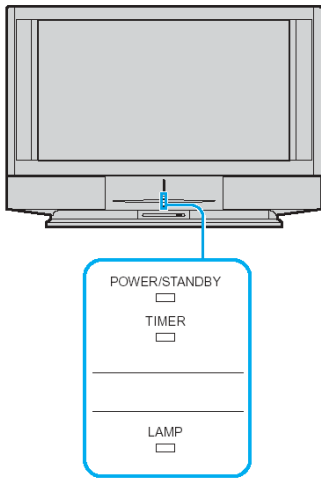

- One blink is not used for self-diagnosis.

- Example

Diagnosis item LED blinks

Lamp cover 3 times

Fan 4 times

LED ON : 0.3sec

LED OFF : 0.3sec

LED OFF
3.0sec

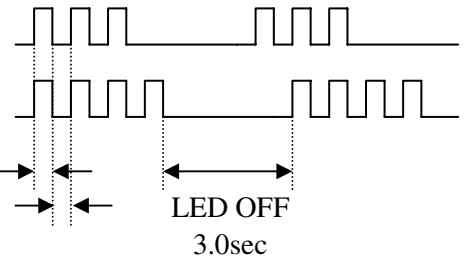

- Release of POWER/STANDBY indicator blinking

The POWER/STANDBY indicator blinking display is released by removing the plug from the power or leaving for 2 minutes.

4. Self-diagnosis screen displays

- In cases of malfunctions where it is not possible to determine the symptom such as when the power goes off occasionally or when the screen disappears occasionally, there is a screen display on whether the malfunction occurred or not in the past (and whether the detection circuit operated or not) in order to allow confirmation.

<Screen Display Method>

- Quickly press the remote command button in the following order from the standby state.

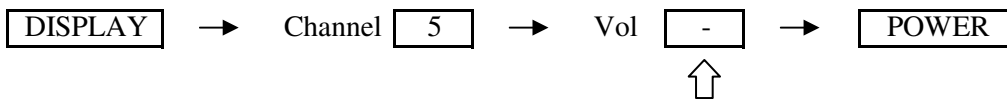

Be aware that this differs from the method of entering the service mode (Vol +).

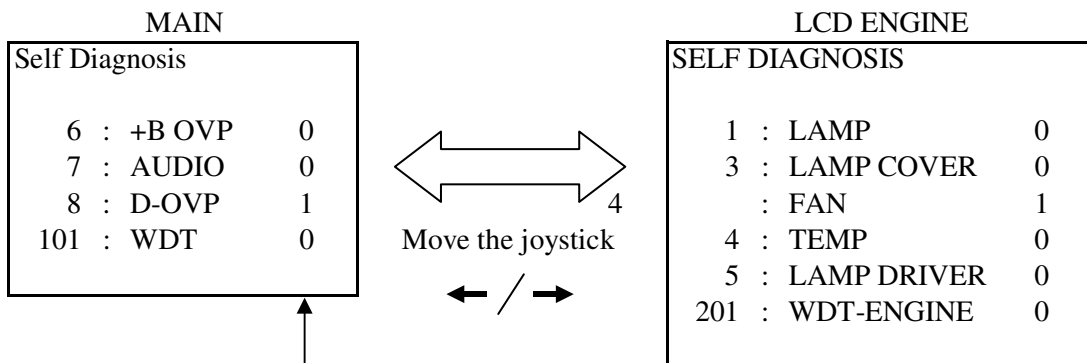

- Numeral "1" means a fault was detected one time or more.
- Numeral "0" means that no fault was detected.

- The results display is not automatically cleared. In case of repairs and after repairs, check the self-diagnosis screen and be sure to return the results display to "0".
- If the results display is not returned to "0" it will not be possible to judge a new malfunction after completing repairs.

<Method of Clearing Results Display>

1. Power off (Set to the standby mode)
2. **DISPLAY** → Channel **5** → Vol **-** → **POWER**
3. Channel **8** → **ENTER**
4. Wait until appearing the initial setup display.
5. Disconnect AC plug and connect it again.

<Method of Ending Self-Diagnosis Screen>

- When ending the self-diagnosis screen completely, turn the power switch OFF on the remote commander or the main unit.

5. Self-Diagnosis function operation

- 3 : Lamp cover When lamp cover SW is opened then pin 3 of CN8014 on the A board is high, LCD Engine u-com (pin 27 of IC3208 on the C2 board) detects it and make turn off the lamp.
- 4 : Fan When Fan1 or Fan2 or Fan3 is stopped then pin 2 or 5 or 8 of CN8022 on the A board is high, LCD Engine u-com (pin 24 of IC3208 on the C2 board) detects it and make turn off the lamp.
- 4 : Temp When a temperature sensor on the H3 board detects a high temperature or IIC-E line connector (CN8023:A board,CN44:H3 board) is not attached securely, LCD Engine u-com IIC-E line detects it and make turn off the lamp.
- 5 : Lamp driver When lamp is not turned on then pin 29 of LCD Engine u-com (IC3208 on the C2 board) is high, checks pin 28 of LCD Engine u-com. If pin 28 is low, it is judged no high voltage.
- 6 : +B OVP When +17V line drop then pin 53 of MAIN u-com (IC3405 on the C2 board) is low, it turns off the main power.
- 7 : Audio When DC is appeared by audio amp failure at speaker line. Then it is detected by MAIN u-com (pin 59 of IC3405 on the C2 board) and it turns off the main power.
- 8 : D-OVP When +3.3V or +2.5V or +1.8V line over then pin 49 of MAIN u-com (IC3405 on the C2 board) is low, it turns off the main power.
- LAMP : Lamp When lamp is not turned on then pin 29 of LCD Engine u-com (IC3208 on the C2 board) is high, checks pin 28 of LCD Engine u-com. If pin 28 is high, it is judged lamp is burned out.

<Self-Diagnosis block diagram>

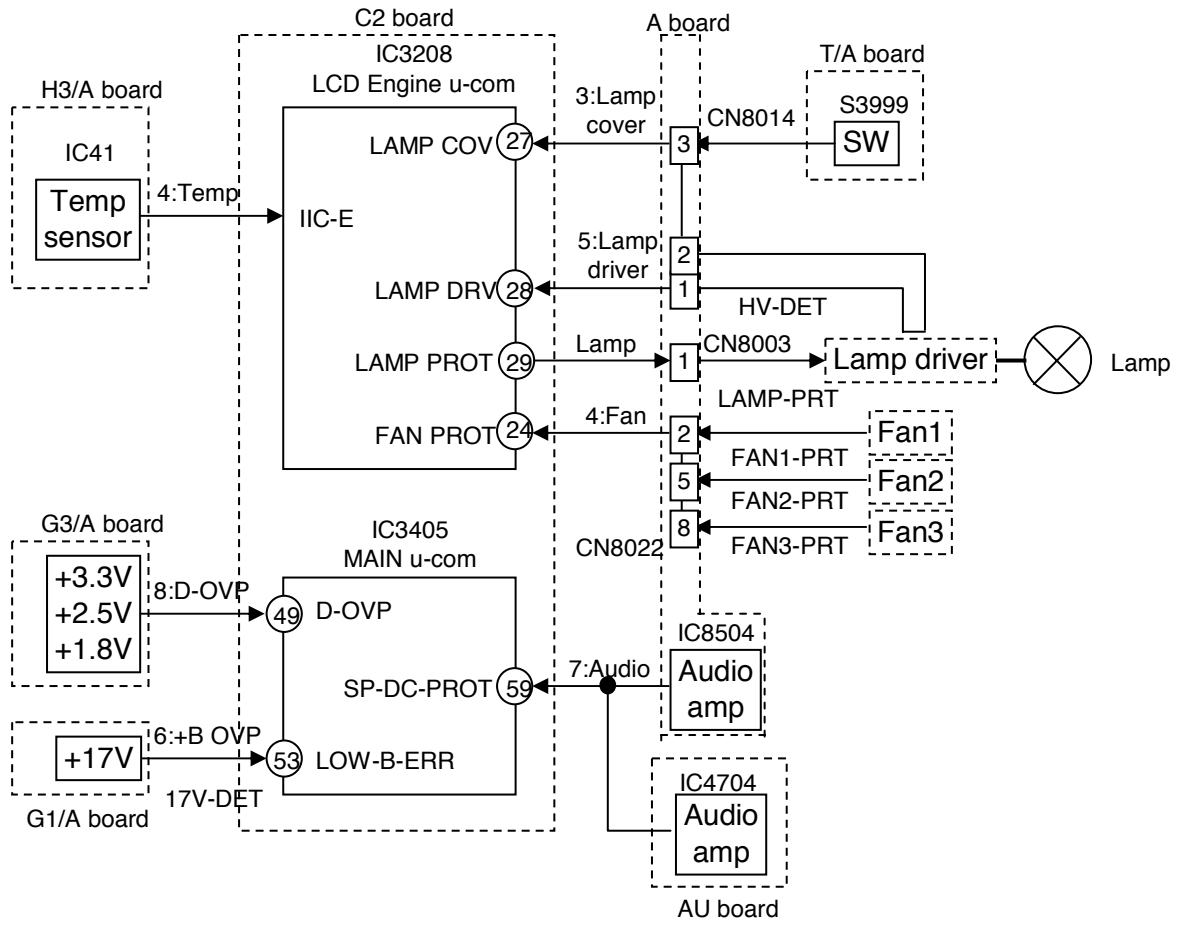

SECTION 2 DISASSEMBLY

2-1. REAR COVER

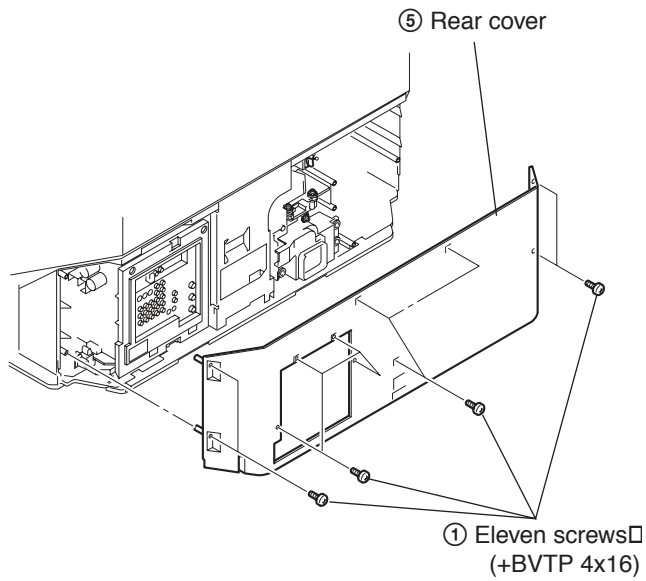

2-3. SERVICE POSITION

Note: In case of the model 60WE610,
first remove reinforcement plates (R)/(L).

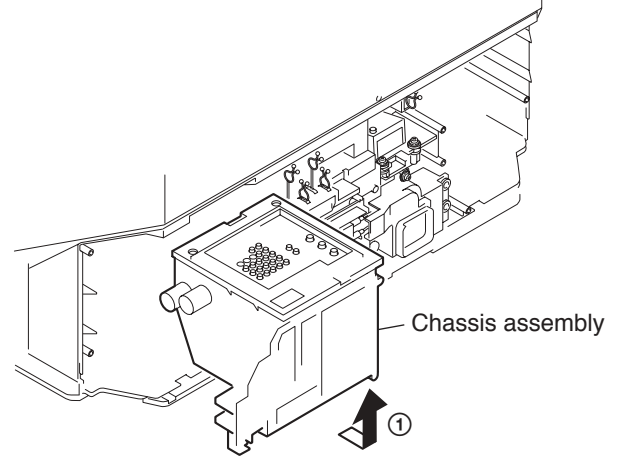

2-2. CENTER PILLAR

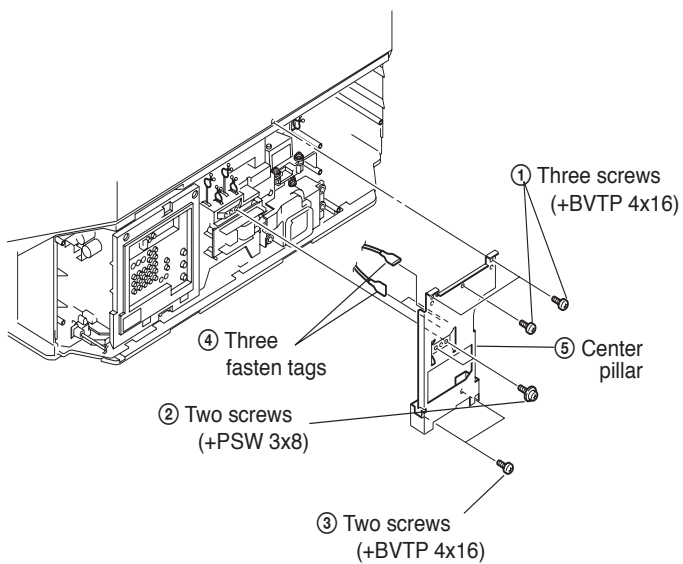

2-4. CHASSIS ASSEMBLY, OPTICAL UNIT BLOCK, D. C. FAN

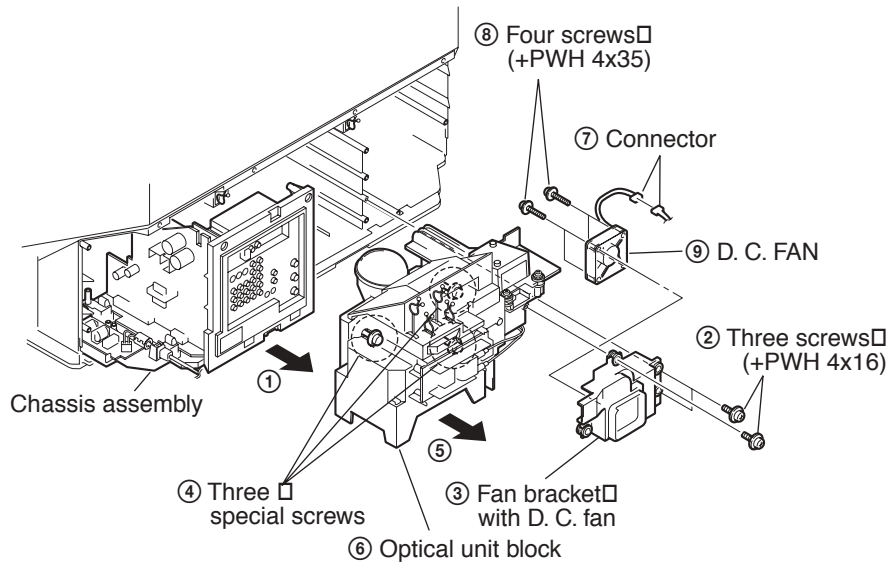

2-5. UD BOARD, RF ANTENNA SWITCH

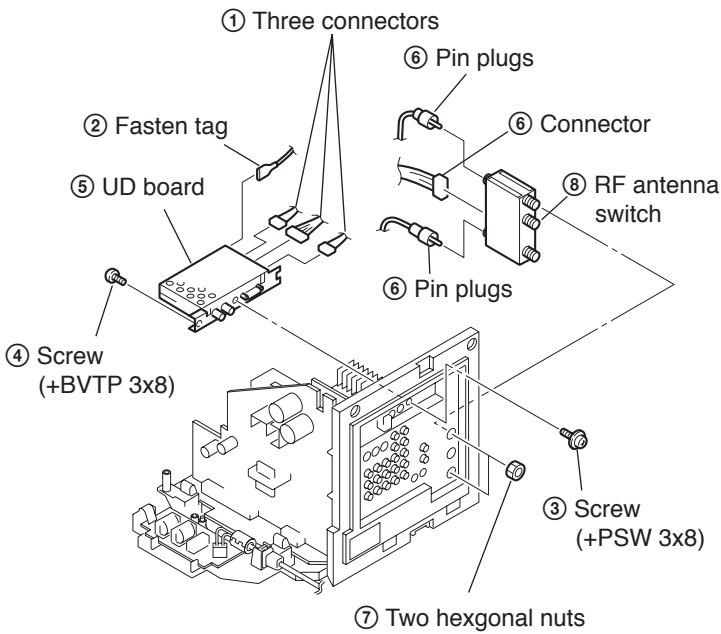

2-6. U BOARD

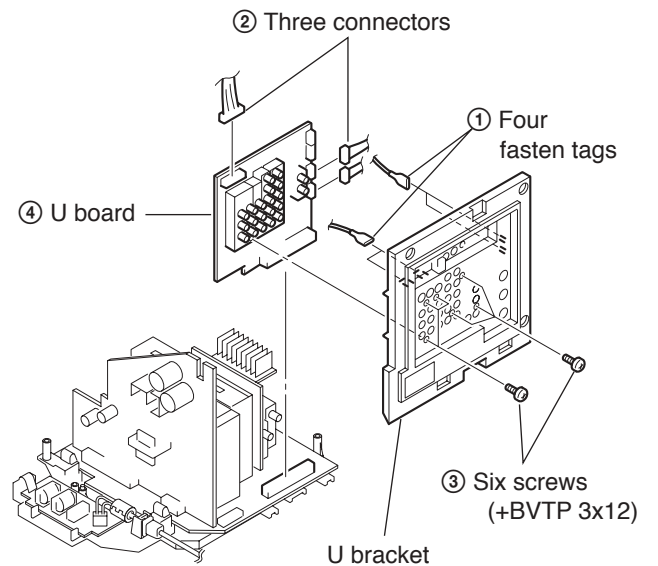

2-7. F AND G1 BOARDS

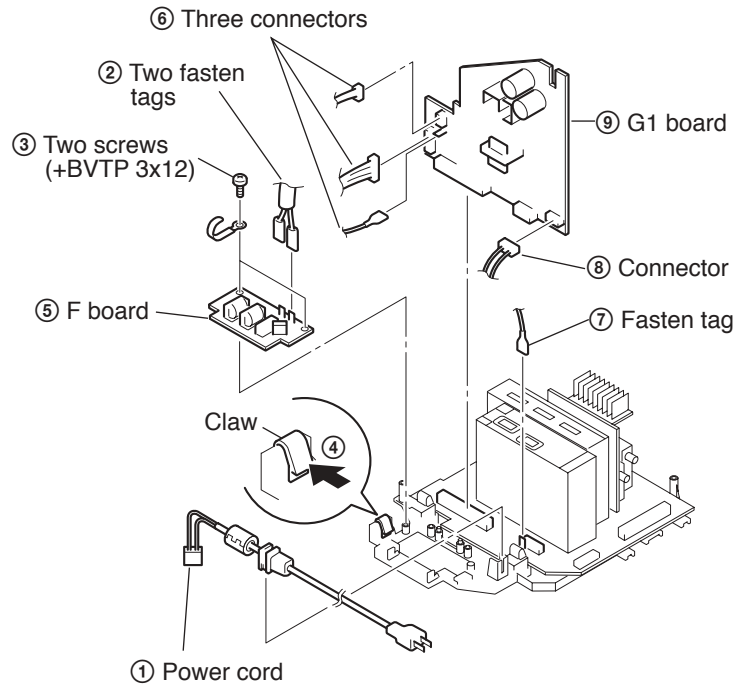

2-8. DIC BLOCK, AU AND C2 BOARDS

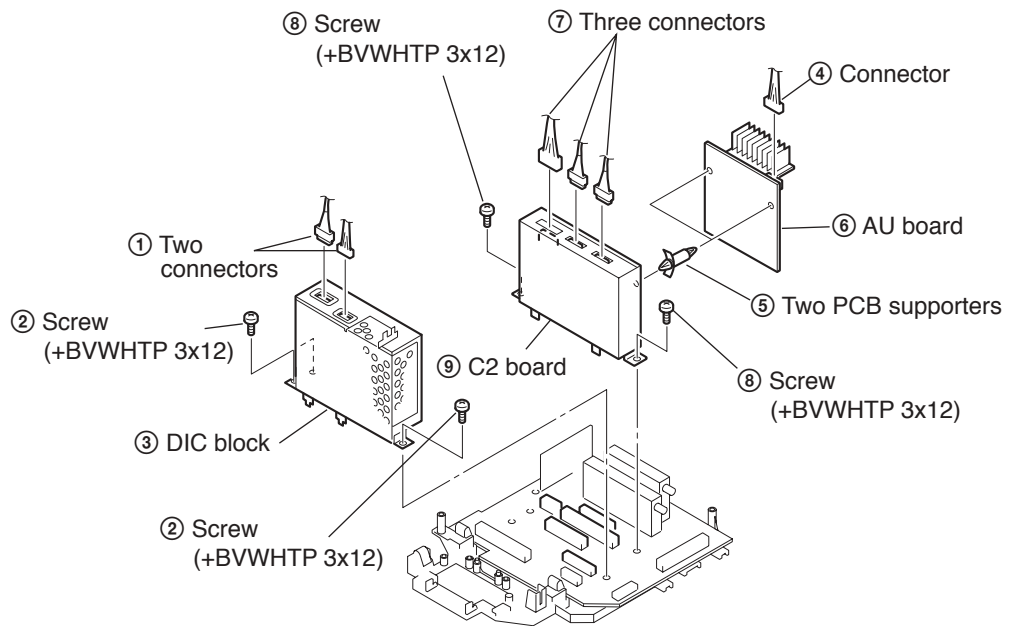

2-9. A BOARD

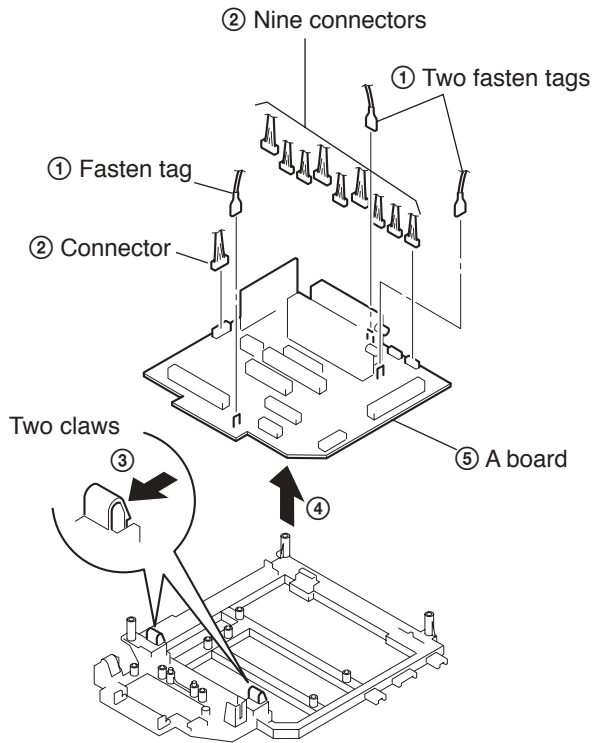

2-11. T BOARD

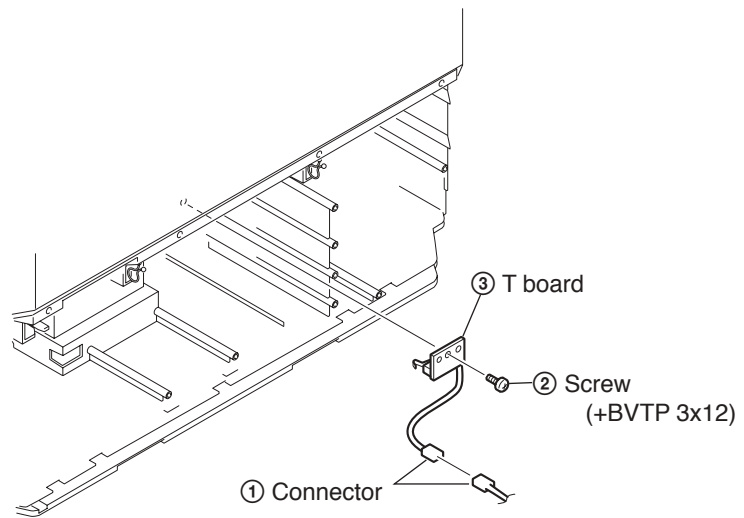

2-10. POWER SUPPLY BLOCK

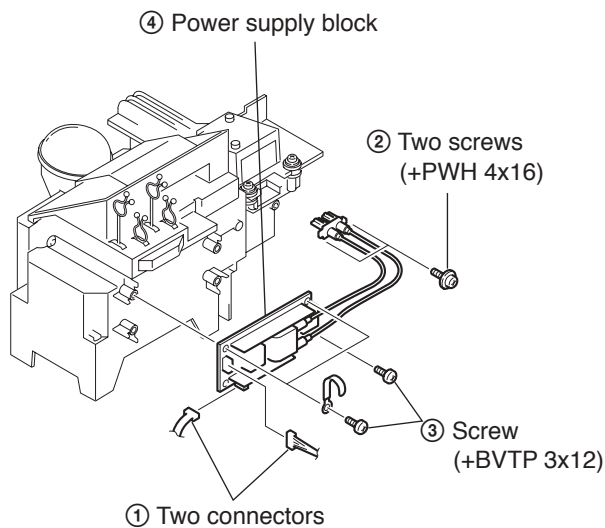

2-12. H3 BOARD (42WE610)

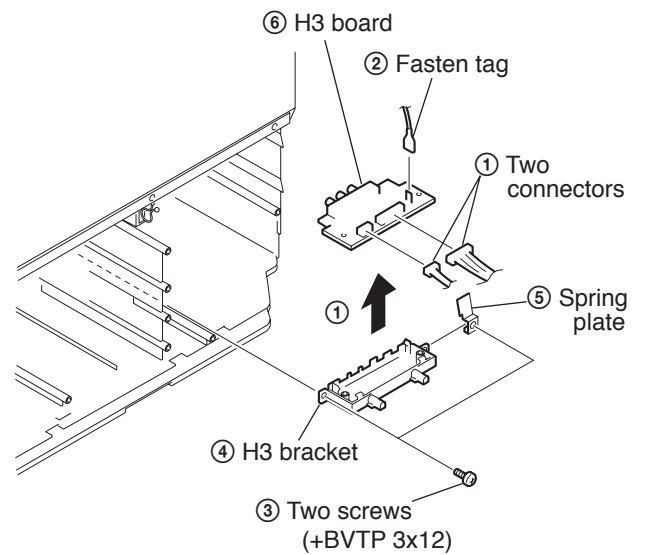

2-13. FRONT COVER ASSEMBLY

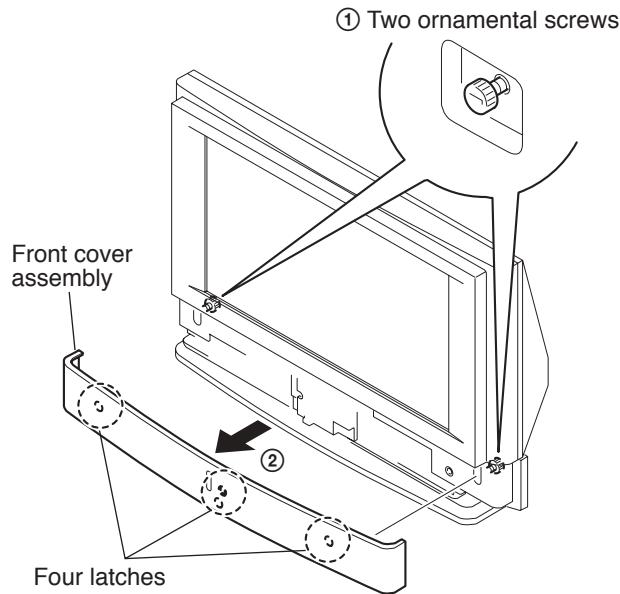

2-14. HM AND H3 BOARDS (50WE610/60WE610)

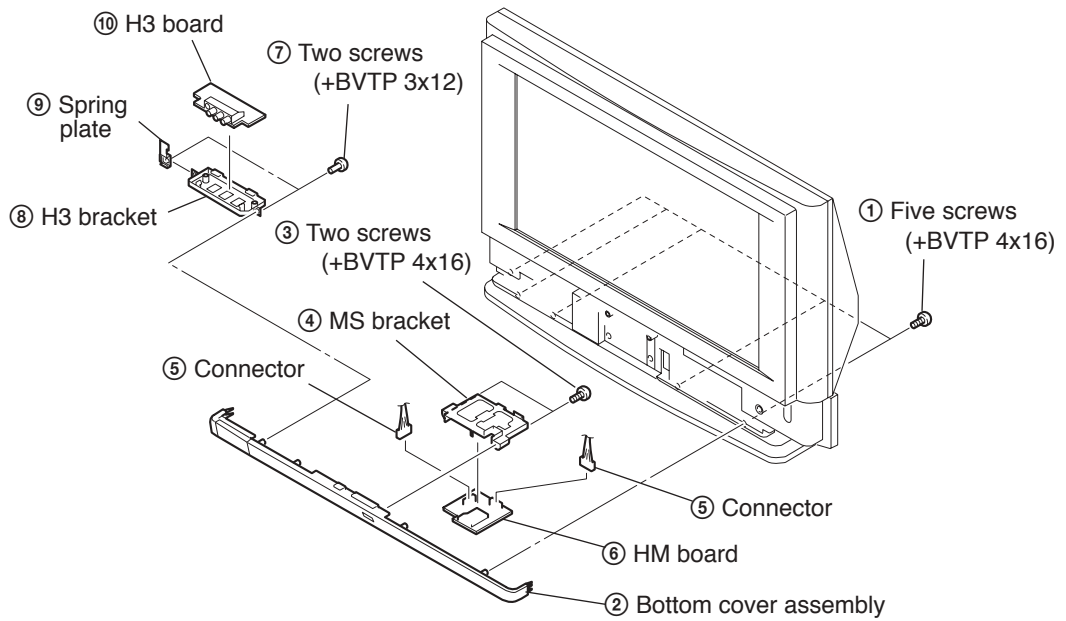

2-15. H2 BOARD

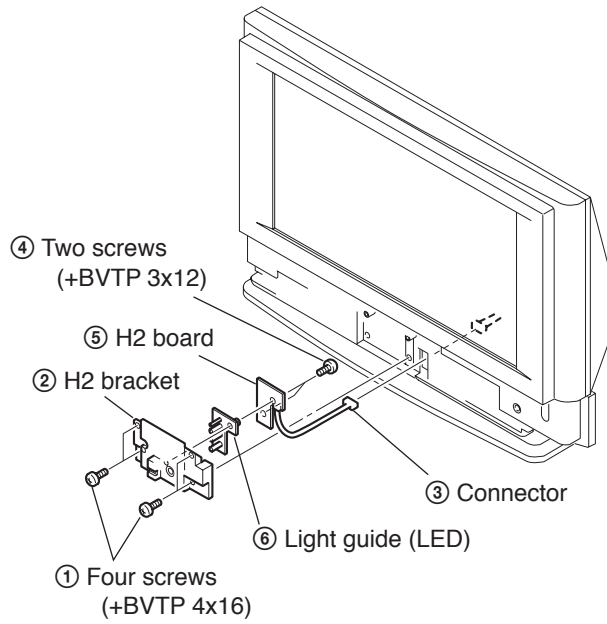

2-16. HM BOARD (42WE610)

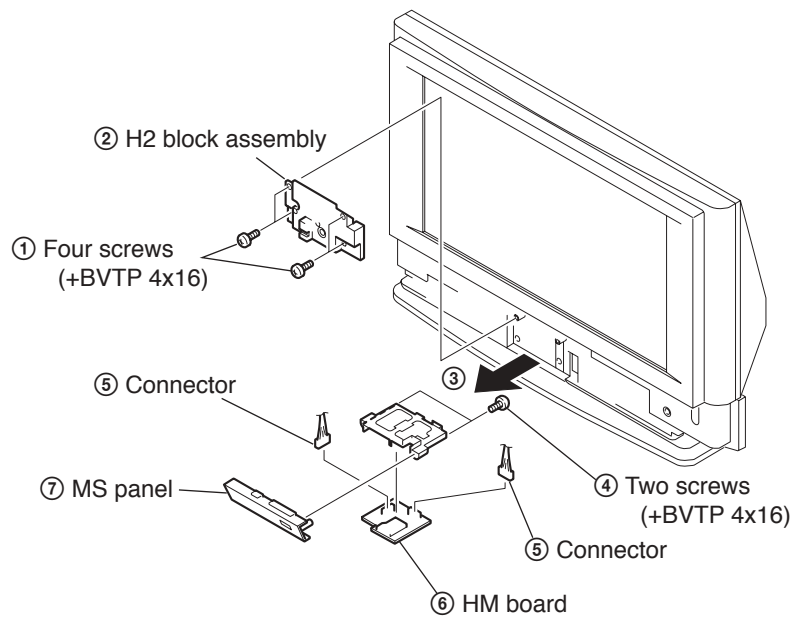

2-17. SCREEN MIRROR BLOCK ASSEMBLY

Note: In case of the model 50WE610/60WE610, it is need to remove the screws secured the reinforcement plates (R)/(L).

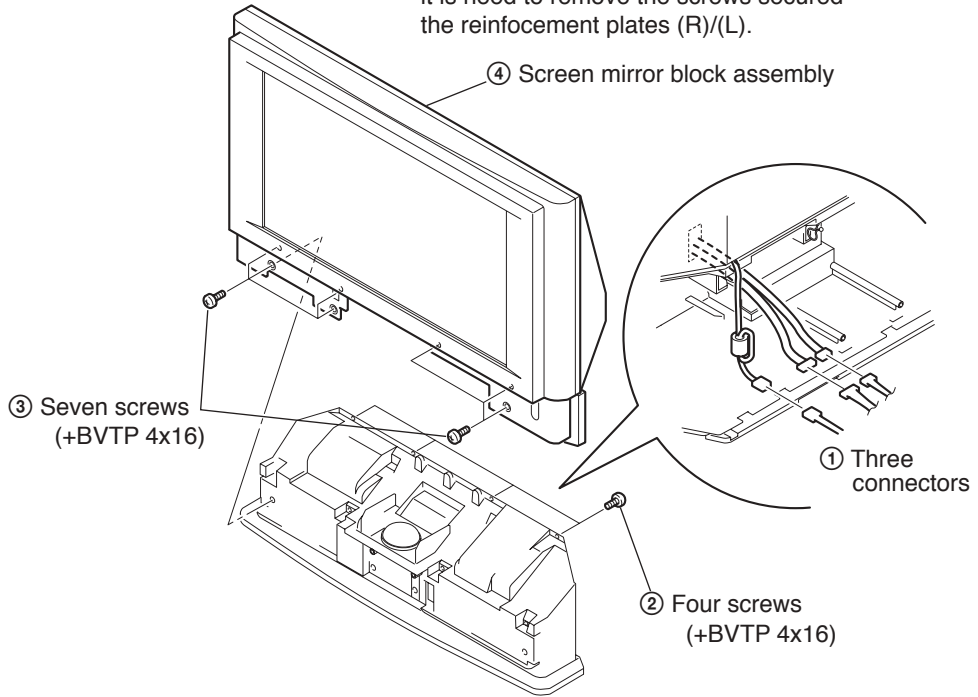

2-18. H1 BOARD

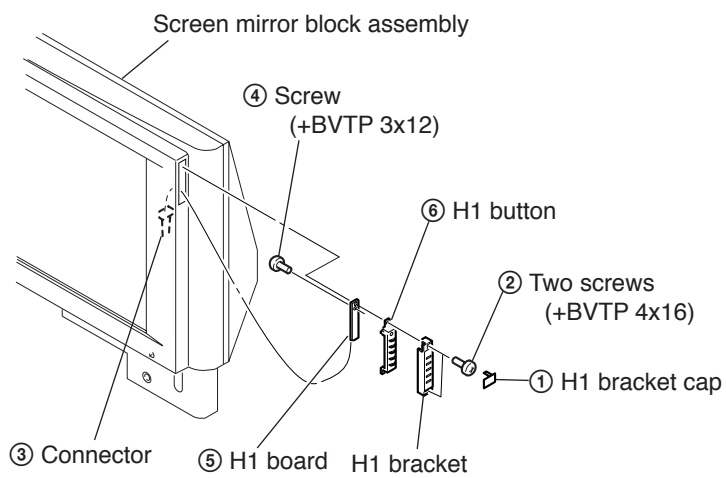

SECTION 3

ELECTRICAL ADJUSTMENTS

3-1. ELECTRICAL ADJUSTMENT BY REMOTE COMMANDER

By using remote commander (RM-Y910K), all circuit adjustments can be made.

NOTE : Test Equipment Required.

1. Pattern Generator (with component outputs)
2. Oscilloscope
3. Digital multimeter

3-1-1. Method of Setting the Service Adjustment Mode

1. Standby mode. (Power off)
2. **DISPLAY** → **5** → **VOL (+)** → **TV POWER** on the remote commander.
(Press each button within a second.)
The following service screen will appear.

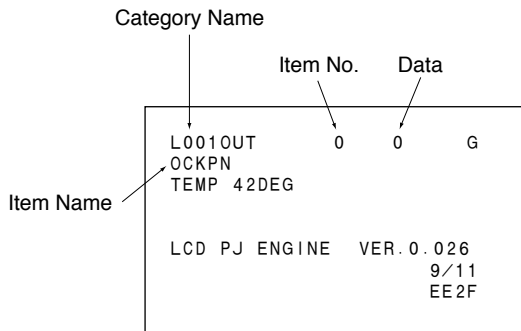
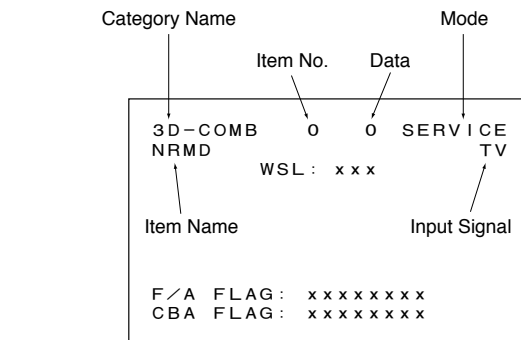

<LCD PROJECTOR ENGINE>

3-1-2. Service Mode Adjustment

1. The SCREEN displays the item being adjusted.
2. Press “①” or “④” on the remote commander to select the adjustment item.
3. Press “③” or “⑥” on the remote commander to change the data.
4. Press “②” or “⑤” on the remote commander to select the category.
Every time you press “②” (Category up), Service mode changes in the order as shown below.

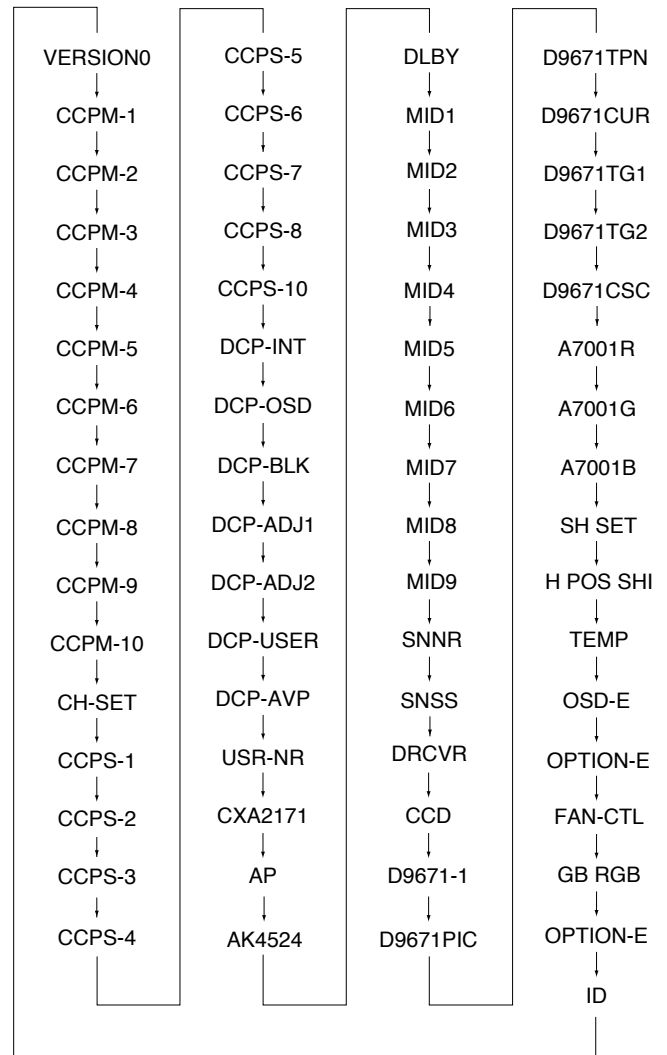

5. If you want to recover the latest values press “⑩” then “**ENTER**” to read the memory.
6. Press “**MUTING**” then “**ENTER**” to write into memory.
7. Turn power off.

Note: Press “⑧” then “**ENTER**” on the remote commander to set the shipping conditions or turn set off and on to exit.

3-1-3. Memory Write Confirmation Method

1. After adjustment, turn power off with the remote commander.
2. Turn power on and set to service mode.
3. Call the adjusted items again and confirm they were adjusted.

3-1-4. Adjusting Buttons and Indicator

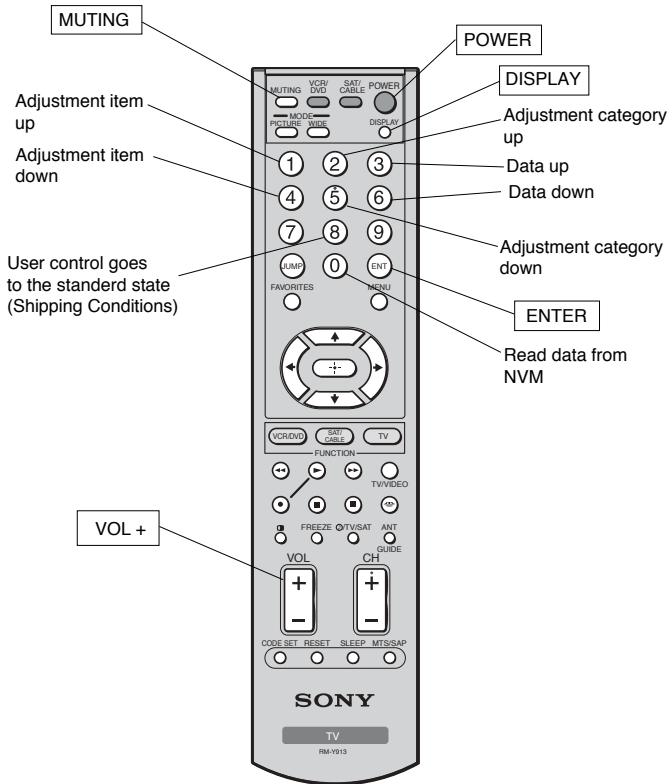

RM-Y913

FUNCTION OF KEYS ON COMMANDER

- ① : Changes adjustment item. (item No. moves up)
- ④ : Changes adjustment item. (item No. moves down)
- ② : Changes adjustment category. (category moves up)
- ⑤ : Changes adjustment category. (category moves down)
- ③ : Changes data value. (up)
- ⑥ : Changes data value. (down)

Commander Function

Button	Mode	Description
MUTING + ENTER	WRITE	Writes data to NVM.
0 + ENTER	READ	Reads data from NVM.
8 + ENTER	RESET	Set the shipping condition.

(Be sure not to use usually)

3-1-5. Service Mode List

Note: • shaded items are fixed. There is no need to change data. Others are different a little in the sets individually. Basically, there is no need to change data, too.

CCPM-1

Functionality		Data	Remarks
No.	Name		
0	SHPC	*1	
1	FUP2	*1	
2	YNR	*1	
3	CNR	*1	
4	SSHP	*1	
5	YEQ	*1	
6	SHF0	*1	
7	SECA	*2	
8	YCDL	*3	
9	YLEV	*3	
10	CLEV	*3	
11	SHUE	*4	
12	CEQ	*4	
13	CBPF	*4	
14	CBPA	*4	
15	KILV	*4	
16	APGA	*4	
17	NCOM	*4	

Standards *1

No.	Name	UV				Video			
		Vivid	Standard	Pro	Reserved	Vivid	Standard	Pro	Reserved
0	SHPC	1	1	1	0	1	1	1	0
1	FUP2	0	0	0	0	0	0	0	0
2	YNR	0	0	0	0	0	0	0	0
3	CNR	0	0	0	0	0	0	0	0
4	SSHP	2	1	1	7	5	5	5	7
5	YEQ	3	1	1	3	1	1	1	3
6	SHF0	1	1	1	1	1	1	1	1

No.	Name	Component(AVM(YCbCr))							
		480i				480p			
		Vivid	Standard	Pro	Reserved	Vivid	Standard	Pro	Reserved
0	SHPC	0	0	0	0	0	0	0	0
1	FUP2	0	0	0	0	0	0	0	0
2	YNR	0	0	0	0	0	0	0	0
3	CNR	0	0	0	0	0	0	0	0
4	SSHP	7	7	7	7	7	7	7	7
5	YEQ	3	3	3	3	3	3	3	3
6	SHF0	1	1	1	1	1	1	1	1

No.	Name	Component(AVM(YCbCr))							
		1080i				720p			
		Vivid	Standard	Pro	Reserved	Vivid	Standard	Pro	Reserved
0	SHPC	0	0	0	0	0	0	0	0
1	FUP2	0	0	0	0	0	0	0	0
2	YNR	0	0	0	0	0	0	0	0
3	CNR	0	0	0	0	0	0	0	0
4	SSHP	7	7	7	7	7	7	7	7
5	YEQ	3	3	3	3	3	3	3	3
6	SHF0	1	1	1	1	1	1	1	1

No.	Name	DVI(AVM(RGB)/DVI)							
		480i				480p			
		Vivid	Standard	Pro	Reserved	Vivid	Standard	Pro	Reserved
0	SHPC	0	0	0	0	0	0	0	0
1	FUP2	0	0	0	0	0	0	0	0
2	YNR	0	0	0	0	0	0	0	0
3	CNR	0	0	0	0	0	0	0	0
4	SSHP	7	7	7	7	7	7	7	7
5	YEQ	3	3	3	3	3	3	3	3
6	SHF0	1	1	1	1	1	1	1	1

No.	Name	DVI(AVM(RGB)/DVI)							
		1080i				720p			
		Vivid	Standard	Pro	Reserved	Vivid	Standard	Pro	Reserved
0	SHPC	0	0	0	0	0	0	0	0
1	FUP2	0	0	0	0	0	0	0	0
2	YNR	0	0	0	0	0	0	0	0
3	CNR	0	0	0	0	0	0	0	0
4	SSHP	7	7	7	7	7	7	7	7
5	YEQ	3	3	3	3	3	3	3	3
6	SHF0	1	1	1	1	1	1	1	1

No.	Name	DVI(AVM(RGB)/DVI)			
		VGA(VGA/OTHER)			
		Vivid	Standard	Pro	Reserved
0	SHPC	0	0	0	0
1	FUP2	0	0	0	0
2	YNR	0	0	0	0
3	CNR	0	0	0	0
4	SSHP	7	7	7	7
5	YEQ	3	3	3	3
6	SHF0	1	1	1	1

No.	Name	i.LINK(ex DV) for XBR/BS/CS/i.LINK(ex DV)							
		480i(ex DV Format)(480i)				480p			
		Vivid	Standard	Pro	Reserved	Vivid	Standard	Pro	Reserved
0	SHPC	0	0	0	0	0	0	0	0
1	FUP2	0	0	0	0	0	0	0	0
2	YNR	0	0	0	0	0	0	0	0
3	CNR	0	0	0	0	0	0	0	0
4	SSHP	7	7	7	7	7	7	7	7
5	YEQ	3	3	3	3	3	3	3	3
6	SHF0	1	1	1	1	1	1	1	1

No.	Name	i.LINK(ex DV) for XBR(BS/CS/i.LINK(ex DV))							
		1080i				720p			
		Vivid	Standard	Pro	Reserved	Vivid	Standard	Pro	Reserved
0	SHPC	0	0	0	0	0	0	0	0
1	FUP2	0	0	0	0	0	0	0	0
2	YNR	0	0	0	0	0	0	0	0
3	CNR	0	0	0	0	0	0	0	0
4	SSHP	7	7	7	7	7	7	7	7
5	YEQ	3	3	3	3	3	3	3	3
6	SHF0	1	1	1	1	1	1	1	1

No.	Name	i.LINK for XBR(BS/CS/i.LINK(ex DV))				i.LINK(DV)			
		480i(DV Format)Lower							
		Vivid	Standard	Pro	Mild	Vivid	Standard	Pro	Reserved
0	SHPC	0	0	0	0	0	0	0	0
1	FUP2	0	0	0	0	0	0	0	0
2	YNR	0	0	0	0	0	0	0	0
3	CNR	0	0	0	0	0	0	0	0
4	SSHP	7	7	7	7	7	7	7	7
5	YEQ	3	3	3	3	3	3	3	3
6	SHF0	1	1	1	1	1	1	1	1

No.	Name	ATSC for XBR(DTT/ATSC)							
		480i				480p			
		Vivid	Standard	Pro	Reserved	Vivid	Standard	Pro	Reserved
0	SHPC	0	0	0	0	0	0	0	0
1	FUP2	0	0	0	0	0	0	0	0
2	YNR	0	0	0	0	0	0	0	0
3	CNR	0	0	0	0	0	0	0	0
4	SSHP	7	7	7	7	7	7	7	7
5	YEQ	3	3	3	3	3	3	3	3
6	SHF0	1	1	1	1	1	1	1	1

No.	Name	ATSC for XBR(DTT/ATSC)							
		1080i				720p			
		Vivid	Standard	Pro	Reserved	Vivid	Standard	Pro	Reserved
0	SHPC	0	0	0	0	0	0	0	0
1	FUP2	0	0	0	0	0	0	0	0
2	YNR	0	0	0	0	0	0	0	0
3	CNR	0	0	0	0	0	0	0	0
4	SSHP	7	7	7	7	7	7	7	7
5	YEQ	3	3	3	3	3	3	3	3
6	SHF0	1	1	1	1	1	1	1	1

No.	Name	ATSC(DTT/ATSC)			
		Lower			
		Vivid	Standard	Pro	Mild
0	SHPC	0	0	0	0
1	FUP2	0	0	0	0
2	YNR	0	0	0	0
3	CNR	0	0	0	0
4	SSHP	7	7	7	7
5	YEQ	3	3	3	3
6	SHF0	1	1	1	1

No.	Name	MS for XBR(DATA(ADD))							
		STILL(1080i)(480i)				MOVIE(CONT-PANEL) (OTHER)			
		Vivid	Standard	Pro	Reserved	Vivid	Standard	Pro	Reserved
0	SHPC	0	0	0	0	0	0	0	0
1	FUP2	0	0	0	0	0	0	0	0
2	YNR	0	0	0	0	0	0	0	0
3	CNR	0	0	0	0	0	0	0	0
4	SSHP	7	7	7	7	7	7	7	7
5	YEQ	3	3	3	3	3	3	3	3
6	SHF0	1	1	1	1	1	1	1	1

No.	Name	MS for XBR(DATA(INDEPENDENT))							
		MOVIE(LOW) (480i)				MOVIE(HIGH) OTHER			
		Vivid	Standard	Pro	Reserved	Vivid	Standard	Pro	Mild
0	SHPC	0	0	0	0	0	0	0	0
1	FUP2	0	0	0	0	0	0	0	0
2	YNR	0	0	0	0	0	0	0	0
3	CNR	0	0	0	0	0	0	0	0
4	SSHP	7	7	7	7	7	7	7	7
5	YEQ	3	3	3	3	3	3	3	3
6	SHF0	1	1	1	1	1	1	1	1

Standards *2

No.	Name	UV	Video
7	SECA	10	10

No.	Name	Component(AVM(YCbCr))				DVI(AVM(RGB)/DVI)				
		480i	480p	1080i	720p	480i	480p	1080i	720p	VGA(VGA/OTHER)
7	SECA	0	0	0	0	0	0	0	0	0

No.	Name	i.LINK(ex DV) for XBR(BS/CS/i.LINK(ex DV))					i.LINK(DV)
		480i(ex DV)	480p	1080i	720p	Lower	
7	SECA	0	0	0	0	0	0

No.	Name	ATSC(DTT/ATSC)				
		480i	480p	1080i	720p	Lower
7	SECA	0	0	0	0	0

No.	Name	DATA(ADD)		DATA(INDEPENDENT)	
		480i	OTHER	480i	OTHER
7	SECA	0	0	0	0

Standards *3

No.	Name	UV	Video	Component (not 480i)	ATSC for XBR (not 480i)(AVM(Y/Cb/Cr))	DVI (not 480i) (AVM(RGB)/DVI)	i.LINK (480i and ex DV) for XBR	i.LINK(DV)	MS for XBR (DTT/ATSC)
8	YCDL	8	8	7	7	7	7	7	7
9	YLEV	175	175	175	175	175	175	175	175
10	CLEV	97	97	185	185	185	185	185	185

No.	Name	Component (480i)	ATSC for XBR (480i) (AVM(Y/Cb/Cr))	DVI (480i) (AVM(RGB)/DVI)	i.LINK (not 480i and ex DV) for XBR
8	YCDL	7	7	7	7
9	YLEV	175	175	175	175
10	CLEV	185	185	185	185

Standards *4

No.	Name	UV			Video
		UV(GR OFF)	GR ON		
			GCR ON	GCR OFF	
11	SHUE	7	7	7	7
12	CEQ	3	1	1	0
13	CBPF	3	2	2	0
14	CBPA	0	1	1	0
15	KILV	2	2	2	2
16	APGA	0	0	0	0
17	NCOM	0	0	0	0

CCPM-2

Functionality		Data	Remarks
No.	Name		
0	PACK	*1	
1	CLPP	*2	
2	SSEP	*2	
3	CLPG	*2	
4	CLPA	*2	
5	AFCV	*2	
6	HSSL	*2	
7	VSSL	*2	
8	STIP	*2	
9	SYLP	*2	
10	SYFI	*2	
11	AFCG	*2	
12	LOWG	*2	
13	AFCM	*2	
14	LOCO	*2	
15	HICO	*2	
16	CDM1	*2	
17	CDM2	*2	
18	CDM3	*2	
19	BGPS	*2	
20	VINT	*2	
21	HSPO	*2	
22	MVSW	*2	
23	MVCT	*2	
24	MVHC	*2	
25	CLAL	*2	
26	ADPS	*2	
27	CLGA	*2	
28	YTRP	*2	
29	CTRP	*2	
30	CROF	*2	
31	SDLP	*2	
32	ROM2	*2	

Standards *1

No.	Name	UV	Video1	Video2	Video3	Video4
0	PACK	0	4	4	4	4

No.	Name	Video5(COMPLEMENT1)				Video6(COMPLEMENT2)			
		480i	480p	1080i	720p	480i	480p	1080i	720p
0	PACK	5	6	7	8	5	6	7	8

No.	Name	i.LINK/ATSC/MS for XBR(AVM(YCbCr))				DVI(AVM(RGB)/DVI)				
		480i	480p	1080i	720p	480i	480p	1080i	720p	VGA/OTHER
0	PACK	5	6	7	8	5	6	7	8	13

Standards *2

No.	Name	PACK = 0	PACK = 1	PACK = 2	PACK = 3	PACK = 4	PACK = 5	PACK = 6	PACK = 7	PACK = 8
1	CLPP	28	28	28	28	28	28	28	28	28
2	SSEP	0	0	0	0	0	0	0	0	0
3	CLPG	0	0	0	0	0	0	0	0	0
4	CLPA	0	0	0	0	0	0	0	0	0
5	AFCV	1	1	1	1	1	1	1	1	1
6	HSSL	2	2	2	2	0	0	0	3	3
7	VSSL	2	2	2	2	2	2	2	3	3
8	STIP	2	2	2	2	2	2	2	2	2
9	SYLP	0	0	0	0	0	0	0	0	0
10	SYFI	1	0	1	0	1	1	0	0	0
11	AFCG	1	1	2	2	0	1	1	1	1
12	LOWG	0	0	0	0	0	0	0	0	0
13	AFCM	0	0	0	0	0	0	0	0	0
14	LOCO	0	0	0	0	0	0	0	0	0
15	HICO	0	0	0	0	0	0	0	0	0
16	CDM1	2	2	2	2	2	2	2	2	2
17	CDM2	0	0	0	0	0	0	0	0	0
18	CDM3	0	0	0	0	0	0	0	0	0
19	BGPS	10	10	10	10	10	10	10	10	10
20	VINT	7	7	7	7	7	7	7	3	7
21	HSPO	7	7	7	7	7	7	7	7	7
22	MVSW	2	2	2	2	2	2	2	2	2
23	MVCT	7	7	7	7	7	7	7	7	7
24	MVHC	4	4	4	4	4	4	4	4	4
25	CLAL	0	0	0	0	0	0	0	0	0
26	ADPS	0	0	0	0	0	0	0	0	0
27	CLGA	2	2	2	2	2	2	2	2	2
28	YTRP	1	1	1	1	1	0	0	0	0
29	CTRP	1	1	1	1	1	0	0	0	0
30	CROF	1	1	1	1	1	1	1	1	1
31	SDLP	1	1	1	1	1	0	0	0	0
32	ROM2	0	0	0	0	0	0	0	0	0

No.	Name	PACK = 9	PACK = 10	PACK = 11	PACK = 12	PACK = 13	PACK = 14	PACK = 15
1	CLPP	28	28	28	28	28	28	28
2	SSEP	0	0	0	0	0	0	0
3	CLPG	0	0	0	0	0	0	0
4	CLPA	0	0	0	0	0	0	0
5	AFCV	1	1	1	1	1	1	1
6	HSSL	1	1	1	1	0	2	2
7	VSSL	2	2	2	2	2	2	2
8	STIP	2	2	2	2	2	2	2
9	SYLP	0	0	0	0	0	0	0
10	SYFI	1	0	1	0	0	1	1
11	AFCG	1	1	2	2	1	2	3
12	LOWG	0	0	0	0	0	1	3
13	AFCM	0	0	0	0	0	0	0
14	LOCO	0	0	0	0	0	0	0
15	HICO	0	0	0	0	0	0	0
16	CDM1	2	2	2	2	2	2	2
17	CDM2	0	0	0	0	0	0	0
18	CDM3	0	0	0	0	0	0	0
19	BGPS	10	10	10	10	10	10	10
20	VINT	7	7	7	7	7	7	7
21	HSPO	7	7	7	7	7	7	7
22	MVSW	2	2	2	2	2	2	2
23	MVCT	7	7	7	7	7	7	7
24	MVHC	4	4	4	4	4	4	4
25	CLAL	0	0	0	0	0	0	0
26	ADPS	0	0	0	0	0	0	0
27	CLGA	2	2	2	2	2	2	2
28	YTRP	1	1	1	1	0	1	1
29	CTRP	1	1	1	1	0	1	1
30	CROF	1	1	1	1	1	1	1
31	SDLP	1	1	1	1	0	1	1
32	ROM2	0	0	0	0	0	0	0

CCPM-3

Functionality		Data	Remarks
No.	Name		
0	AD1E	0	
1	APED	*1	
2	AATK	*2	
3	AHLD	*2	
4	AARE	*2	
5	AHIS	*2	
6	DCTR	*1	
7	DCTC	*3	
8	IDIW	*4	
9	WSSO	*4	
10	SLIC	*4	
11	AWOF	*5	
12	UPAR	*5	
13	UPTH	*5	
14	X149	*5	
15	DMST	*5	
16	INST	*5	
17	UPRL	*5	
18	OFSL	*5	
19	SLOF	*5	
20	FR43	*5	
21	FRWI	*5	
22	FRTI	*5	
23	LPFL	*5	
24	4CNT	*5	
25	REFP	*5	
26	REFM	*5	
27	AWSN	*5	
28	AWRE	*5	

Standards *1

No.	Name	AD1E = 1 Or MULTI(TWIN,FAVORITES)						
		480i(RF/Video/Component480i)						
		Vivid	Standard	Pro				Reserved
BLK Correction Off	BLK Correction L			BLK Correction M	BLK Correction H			
1	APED	2	1	0	1	2	3	1
6	DCTR	2	1	0	1	2	3	1

No.	Name	AD1E = 1 Or MULTI(TWIN,FAVORITES)						
		480p						
		Vivid	Standard	Pro				Reserved
BLK Correction Off	BLK Correction L			BLK Correction M	BLK Correction H			
1	APED	2	1	0	1	2	3	1
6	DCTR	2	1	0	1	2	3	1

No.	Name	AD1E = 1 Or MULTI(TWIN,FAVORITES)						
		1080i/60						
		Vivid	Standard	Pro				Reserved
BLK Correction Off	BLK Correction L			BLK Correction M	BLK Correction H			
1	APED	2	1	0	1	2	3	1
6	DCTR	2	1	0	1	2	3	1

No.	Name	AD1E = 1 Or MULTI(TWIN,FAVORITES)						
		720p/60						
		Vivid	Standard	Pro				Reserved
BLK Correction Off	BLK Correction L			BLK Correction M	BLK Correction H			
1	APED	2	1	0	1	2	3	1
6	DCTR	2	1	0	1	2	3	1

No.	Name	AD1E = 1 Or MULTI(TWIN,FAVORITES)						
		576i						
		Vivid	Standard	Pro				Reserved
BLK Correction Off	BLK Correction L			BLK Correction M	BLK Correction H			
1	APED	3	2	0	1	2	3	1
6	DCTR	3	2	0	1	2	3	1

No.	Name	AD1E = 1 Or MULTI(TWIN,FAVORITES)						
		576p						
		Vivid	Standard	Pro				Reserved
BLK Correction Off	BLK Correction L			BLK Correction M	BLK Correction H			
1	APED	3	2	0	1	2	3	1
6	DCTR	3	2	0	1	2	3	1

No.	Name	AD1E = 1 Or MULTI(TWIN,FAVORITES)						
		1080i/50						
		Vivid	Standard	Pro				Reserved
BLK Correction Off	BLK Correction L			BLK Correction M	BLK Correction H			
1	APED	3	2	0	1	2	3	1
6	DCTR	3	2	0	1	2	3	1

No.	Name	AD1E = 1 Or MULTI(TWIN.FAVORITES)						
		720p/50						
		Vivid	Standard	Pro				Reserved
				BLK Correction Off	BLK Correction L	BLK Correction M	BLK Correction H	
1	APED	3	2	0	1	2	3	1
6	DCTR	3	2	0	1	2	3	1

Standards *2

No.	Name	APED = 0	APED = 1	APED = 2	APED = 3
2	AATK	2	2	2	2
3	AHLD	2	2	2	2
4	AARE	2	2	2	2
5	AHIS	0	0	0	0

Standards *3

No.	Name	DCTR = 0	DCTR = 1	DCTR = 2	DCTR = 3
7	DCTC	2	2	2	2

Standards *4

No.	Name	UV	Video1	Video2	Video3	Video4
8	IDIW	1	1	1	1	1
9	WSSO	0	0	0	0	0
10	SLIC	5	5	5	5	5

No.	Name	Video5(COMPONENT1)		Video6(COMPONENT2)		i.LINK/ATSC for XBR(AVM(YCbCr))	
		480i	480p	480i	480p	480i	480p
8	IDIW	1	1	1	1	1	1
9	WSSO	0	0	0	0	0	0
10	SLIC	5	5	5	5	5	5

Standards *5

No.	Name	UV	Video1	Video2	Video3	Video4
11	AWOF	0	0	0	0	0
12	UPAR	0	0	0	0	0
13	UPTH	0	0	0	0	0
14	X149	0	0	0	0	0
15	DMST	1	1	1	1	1
16	INST	0	0	0	0	0
17	UPRL	1	1	1	1	1
18	OFSL	0	0	0	0	0
19	SLOF	0	0	0	0	0
20	FR43	2	2	2	2	2
21	FRWI	2	2	2	2	2
22	FRTI	2	2	2	2	2
23	LPFL	1	1	1	1	1
24	4CNT	1	1	1	1	1
25	REFP	1	1	1	1	1
26	REFM	5	5	5	5	5
27	AWSN	0	0	0	0	0
28	AWRE	0	0	0	0	0

No.	Name	Video5 480i(COMPONENT1 480i)	Video6 480i(COMPONENT2 480i)	i.LINK/ATSC for XBR 480i (AVM(YCbCr) 480i)	DVI 480i(AVM(RGB) 480i)
11	AWOF	0	0	0	0
12	UPAR	0	0	0	0
13	UPTH	0	0	0	0
14	X149	0	0	0	0
15	DMST	1	1	1	1
16	INST	0	0	0	0
17	UPRL	1	1	1	1
18	OFSL	0	0	0	0
19	SLOF	0	0	0	0
20	FR43	2	2	2	2
21	FRWI	2	2	2	2
22	FRTI	2	2	2	2
23	LPFL	1	1	1	1
24	4CNT	1	1	1	1
25	REFP	1	1	1	1
26	REFM	5	5	5	5
27	AWSN	0	0	0	0
28	AWRE	0	0	0	0

CCPM-4

Functionality		Data	Remarks
No.	Name		
0	CLKS	*1	
1	REFC	*1	
2	SYMD	*1	
3	SIFM	*1	
4	DTO1	*1	
5	DTO2	*1	
6	DTO3	*1	
7	PIX1	*1	
8	PIX2	*1	
9	VLN1	*1	
10	VLN2	*1	
11	SYSC	*1	
12	DSPC	*1	
13	PLLD	*1	
14	PLLR	*1	
15	DCLP	*1	
16	DCON	*1	
17	CO2P	*1	
18	CONV	*1	
19	HO2O	*1	
20	BLKM	*1	
21	OSDL	*1	
22	OSDR	*1	
23	CO2O	*1	
24	COLS	*1	
25	VFRQ	*1	
26	PLLS	*1	
27	PIFW	*1	
28	PIBW	*1	
29	PLL4	*1	
30	CDAD	*1	
31	CDAS	*1	
32	PLD1	*1	
33	PLTS	*1	
34	PLOL	*1	
35	YRND	*1	
36	CRND	*1	

Standards *1

No.	Name	UV		Video				Component, ATSC, DVI				
		3-D	2-D	3-D	2-D	YC	YC	480i	480p	1080i	720p	VGA(DVI)
0	CLKS	0	0	0	0	0	0	0	0	0	0	0
1	REFC	1	1	1	1	1	1	1	1	1	1	1
2	SYMD	0	0	0	0	5	5	8	8	8	8	8
3	SIFM	0	0	0	0	0	0	0	2	3	4	2
4	DTO1	63	63	63	63	63	63	63	63	63	63	63
5	DTO2	254	254	254	254	254	254	254	254	254	254	254
6	DTO3	86	86	86	86	86	86	86	86	86	86	86
7	PIX1	0	0	0	0	0	0	0	0	0	0	0
8	PIX2	0	0	0	0	0	0	0	0	0	0	0
9	VLN1	0	0	0	0	0	0	0	0	0	0	0
10	VLN2	0	0	0	0	0	0	0	0	0	0	0
11	SYSC	1	1	1	1	1	1	1	0	0	0	0
12	DSPC	3	3	3	3	3	3	3	1	1	1	1
13	PLLD	0	0	0	0	0	0	0	0	0	0	0
14	PLLR	1	1	1	1	1	1	1	1	1	1	1
15	DCLP	2	2	2	2	2	2	2	2	2	2	2
16	DCON	0	0	0	0	0	0	0	0	0	0	0
17	CO2P	0	0	0	0	0	0	0	0	0	0	0
18	CONV	0	0	0	0	0	0	0	0	0	0	0
19	HO2O	1	1	1	1	1	1	1	0	0	0	0
20	BLKM	1	1	1	1	1	1	1	1	1	1	1
21	OSDL	3	3	3	3	3	3	3	3	3	3	3
22	OSDR	1	1	1	1	1	1	1	1	1	1	1
23	CO2O	1	1	1	1	1	1	1	0	0	0	0
24	COLS	0	0	0	0	0	0	0	0	0	0	0
25	VFRQ	3	3	3	3	3	3	3	3	3	3	3
26	PLLS	0	0	0	0	0	0	0	0	0	0	0
27	PIFW	0	0	0	0	0	0	0	0	0	0	0
28	PIBW	0	0	0	0	0	0	0	0	0	0	0
29	PLL4	0	0	0	0	0	0	0	0	0	0	0
30	CDAD	0	0	0	0	0	0	0	0	0	0	0
31	CDAS	0	0	0	0	0	0	0	0	0	0	0
32	PLD1	0	0	0	0	0	0	0	0	0	0	0
33	PLTS	0	0	0	0	0	0	0	0	0	0	0
34	PLOL	0	0	0	0	0	0	0	0	0	0	0
35	YRND	1	1	1	1	1	1	1	1	1	1	1
36	CRND	1	1	1	1	1	1	1	1	1	1	1

No.	Name	BS/DTT YC	BS/DTT				MS/CNM for XBR	MS/CNM for WE to CCPS
			480i	480p	1080i	720p		
0	CLKS	0	5	5	5	5	0	4
1	REFC	1	1	1	1	1	1	1
2	SYMD	5	14	14	14	14	8	12
3	SIFM	0	0	2	3	4	3	15
4	DTO1	63	63	63	63	63	63	63
5	DTO2	254	254	254	254	254	254	254
6	DTO3	86	86	86	86	86	86	86
7	PIX1	0	0	0	0	0	0	255
8	PIX2	0	0	0	0	0	0	15
9	VLN1	0	0	0	0	0	0	0
10	VLN2	0	0	0	0	0	0	64
11	SYSC	1	1	0	0	0	0	0
12	DSPC	3	2	0	0	0	1	0
13	PLLD	0	0	0	0	0	0	0
14	PLLR	1	2	1	1	1	1	1
15	DCLP	2	2	2	2	2	2	2
16	DCON	0	0	0	0	0	0	0
17	CO2P	0	0	0	0	0	0	0
18	CONV	0	0	0	0	0	0	0
19	HO2O	0	0	0	0	0	0	0
20	BLKM	1	1	1	1	1	1	1
21	OSDL	3	3	3	3	3	3	3
22	OSDR	1	1	1	1	1	1	1
23	CO2O	0	0	0	0	0	0	0
24	COLS	0	0	0	0	0	0	0
25	VFRQ	3	3	3	3	3	3	3
26	PLLS	0	0	0	0	0	0	0
27	PIFW	0	0	0	0	0	0	0
28	PIBW	0	0	0	0	0	0	0
29	PLL4	0	0	0	0	0	0	0
30	CDAD	0	0	0	0	0	0	0
31	CDAS	0	0	0	0	0	0	0
32	PLD1	0	0	0	0	0	0	0
33	PLTS	0	0	0	0	0	0	0
34	PLOL	0	0	0	0	0	0	0
35	YRND	1	1	1	1	1	1	1
36	CRND	1	1	1	1	1	1	1

CCPM-5

Functionality		Data		Remarks
No.	Name	UV	Video	
0	NSS	8	8	
1	TESS	0	0	
2	NSC	15	15	
3	NSV	1	1	
4	STDH	2	2	
5	SHH	1	1	

CCPM-6

Functionality		Data		Remarks
No.	Name	UV	Video	
0	MC1	4	4	
1	MC2	3	3	
2	CR1	1	1	
3	CR2	1	1	
4	CR3	0	0	
5	CR4	1	1	
6	CCR	2	2	
7	CHED	2	2	
8	CVED	3	3	
9	CR5	4	4	
10	YFLT	4	4	
11	C3LE	1	1	
12	YMFH	3	3	
13	YMFV	1	1	
14	F2SW	0	0	
15	MO1	15	15	
16	MO2	3	3	
17	MNNR	1	1	
18	DTH	2	2	
19	DTV	2	2	
20	DT2D	2	2	
21	DTHP	3	3	
22	DTCR	4	4	
23	D2FC	3	3	
24	D2F	9	9	
25	D2F2	1	1	
26	D2FL	0	0	
27	DC	0	0	
28	CVFT	3	3	
29	HC2F	1	1	
30	MNSW	0	0	
31	MDYB	0	0	
32	LCBP	2	2	
33	BPSE	1	1	
34	CR2H	0	0	
35	IMPR	3	3	
36	IMPS	1	1	
37	IMPL	0	0	
38	PLPL	1	1	
39	MDYE	3	3	
40	PLCL	1	1	
41	BPL2	1	1	
42	HPL	1	1	
43	CVFP	0	0	
44	BPL3	7	7	
45	D2F3	2	2	
46	LPSW	1	1	
47	LCR	1	1	
48	F2CR	1	1	
49	YIR	1	1	
50	MOMO	0	0	

CCPM-7

Functionality		Data		Remarks
No.	Name	UV/Video		
		STANDARD	NOT STANDARD	
0	SCTP	0	2	
1	CYBP	0	0	
2	Y2BP	0	0	
3	C2LE	1	1	
4	DTCN	1	2	
5	VEDL	3	3	
6	HP	2	2	
7	PNR	0	0	
8	NCDT	0	0	
9	H2DD	0	0	
10	THRU	0	0	
11	MCH	15	15	
12	MCV	1	1	
13	PEDS	0	0	
14	MMK	7	7	
15	MKAM	0	0	
16	HGLT	0	0	
17	TESL	0	0	
18	SDOF	0	0	
19	BPOF	1	1	
20	C1L	1	1	
21	CYV	0	0	
22	PAL3	0	0	

CCPM-8

Functionality		Data	Remarks
No.	Name		
0	VECR	*1	
1	VECL	*1	
2	VECN	*1	
3	VEGA	*1	

Standards *1

No.	Name	UV				Video			
		Vivid	Standard	Pro	Reserved	Vivid	Standard	Pro	Reserved
0	VECR	0	0	0	0	0	0	0	0
1	VECL	0	0	0	0	0	0	0	0
2	VECN	2	2	2	2	2	2	2	2
3	VEGA	0	0	0	0	0	0	0	0

CCPM-9

Functionality		Data	Remarks
No.	Name		
0	RNRL	*1	
1	NYLP	*2	
2	NYG	*2	
3	NYPH	*2	
4	NYLM	*2	
5	NCLP	*2	
6	NGC	*2	
7	NCPH	*2	
8	NCLM	*2	
9	RNRM	*1	

Standards *1

No.	Name	UV				Video			
		Vivid	Standard	Pro	Mild	Vivid	Standard	Pro	Mild
0	RNRL	0	0	0	0	0	0	0	0
9	RNRM	0	0	0	0	0	0	0	0

No.	Name	Component(AVM(YCbCr))							
		480i				480p			
		Vivid	Standard	Pro	Mild	Vivid	Standard	Pro	Mild
0	RNRL	0	0	0	0	0	0	0	0
9	RNRM	0	0	0	0	0	0	0	0

No.	Name	Component(AVM(YCbCr))							
		1080i				720p			
		Vivid	Standard	Pro	Mild	Vivid	Standard	Pro	Mild
0	RNRL	0	0	0	0	0	0	0	0
9	RNRM	0	0	0	0	0	0	0	0

No.	Name	DVI(AVM(RGB)/DVI)							
		480i				480p			
		Vivid	Standard	Pro	Mild	Vivid	Standard	Pro	Mild
0	RNRL	0	0	0	0	0	0	0	0
9	RNRM	0	0	0	0	0	0	0	0

No.	Name	DVI(AVM(RGB)/DVI)							
		1080i				720p			
		Vivid	Standard	Pro	Mild	Vivid	Standard	Pro	Mild
0	RNRL	0	0	0	0	0	0	0	0
9	RNRM	0	0	0	0	0	0	0	0

No.	Name	DVI(AVM(RGB)/DVI)			
		VGA(VGA/OTHER)			
		Vivid	Standard	Pro	Mild
0	RNRL	0	0	0	0
9	RNRM	0	0	0	0

No.	Name	i.LINK(ex DV) for XBR(BS/CS/i.LINK(ex DV))							
		480i				480p			
		Vivid	Standard	Pro	Mild	Vivid	Standard	Pro	Mild
0	RNRL	0	0	0	0	0	0	0	0
9	RNRM	0	0	0	0	0	0	0	0

No.	Name	i.LINK(ex DV) for XBR(BS/CS/i.LINK(ex DV))							
		1080i				720p			
		Vivid	Standard	Pro	Mild	Vivid	Standard	Pro	Mild
0	RNRL	0	0	0	0	0	0	0	0
9	RNRM	0	0	0	0	0	0	0	0

No.	Name	BS/CS/i.LINK(ex DV)				i.LINK(DV)			
		Lower				Vivid	Standard	Pro	Mild
		Vivid	Standard	Pro	Mild				
0	RNRL	0	0	0	0	0	0	0	0
9	RNRM	0	0	0	0	0	0	0	0

No.	Name	ATSC(DTT/ATSC)							
		480i				480p			
		Vivid	Standard	Pro	Mild	Vivid	Standard	Pro	Mild
0	RNRL	0	0	0	0	0	0	0	0
9	RNRM	0	0	0	0	0	0	0	0

No.	Name	ATSC(DTT/ATSC)							
		1080i				720p			
		Vivid	Standard	Pro	Mild	Vivid	Standard	Pro	Mild
0	RNRL	0	0	0	0	0	0	0	0
9	RNRM	0	0	0	0	0	0	0	0

No.	Name	ATSC(DTT/ATSC)			
		Lower			
		Vivid	Standard	Pro	Mild
0	RNRL	0	0	0	0
9	RNRM	0	0	0	0

No.	Name	MS for XBR(DATA(ADD))							
		STILL(1080i)(480i)				MOVIE(CONT-PANEL)(OTHER)			
		Vivid	Standard	Pro	Mild	Vivid	Standard	Pro	Mild
0	RNRL	0	0	0	0	0	0	0	0
9	RNRM	0	0	0	0	0	0	0	0

No.	Name	MS for XBR(DATA(IND.))							
		MOVIE(LQ)(480i)				MOVIE(HQ)(OTHER)			
		Vivid	Standard	Pro	Mild	Vivid	Standard	Pro	Mild
0	RNRL	0	0	0	0	0	0	0	0
9	RNRM	0	0	0	0	0	0	0	0

Standards *2

No.	Name	RNRL = 0	RNRL = 1	RNRL = 2	RNRL = 3	RNRL = 4	RNRL = 5	RNRL = 6	RNRL = 7
1	NYLP	0	0	0	0	0	0	0	0
2	NYG	1	1	1	1	1	1	1	1
3	NYPH	13	13	13	13	13	13	13	13
4	NYLM	0	1	4	6	8	10	12	14
5	NCLP	0	0	0	0	0	0	0	0
6	NGC	1	1	1	1	1	1	1	1
7	NCPH	13	13	13	13	13	13	13	13
8	NCLM	0	1	4	6	8	10	12	14

CCPM-10

Functionality		Data	Remarks
No.	Name		
0	BNRL	*1	
1	EDL	*2	
2	LFL	*2	
3	DCT	*2	
4	BLEV	*2	
5	DNE	*2	
6	MRON	*2	
7	FMOD	*2	
8	BNRM	*1	

Standards *1

No.	Name	UV				Video			
		Vivid	Standard	Pro	Mild	Vivid	Standard	Pro	Mild
0	BNRL	0	0	0	0	0	0	0	0
8	BNRM	0	0	0	0	0	0	0	0

No.	Name	Component(AVM(YCbCr))							
		480i				480p			
		Vivid	Standard	Pro	Mild	Vivid	Standard	Pro	Mild
0	BNRL	0	0	0	0	0	0	0	0
8	BNRM	0	0	0	0	0	0	0	0

No.	Name	Component(AVM(YCbCr))							
		1080i				720p			
		Vivid	Standard	Pro	Mild	Vivid	Standard	Pro	Mild
0	BNRL	0	0	0	0	0	0	0	0
8	BNRM	0	0	0	0	0	0	0	0

No.	Name	DVI(AVM(RGB)/DVI)							
		480i				480p			
		Vivid	Standard	Pro	Mild	Vivid	Standard	Pro	Mild
0	BNRL	0	0	0	0	0	0	0	0
8	BNRM	0	0	0	0	0	0	0	0

No.	Name	DVI(AVM(RGB)/DVI)							
		1080i				720p			
		Vivid	Standard	Pro	Mild	Vivid	Standard	Pro	Mild
0	BNRL	0	0	0	0	0	0	0	0
8	BNRM	0	0	0	0	0	0	0	0

No.	Name	DVI(AVM(RGB)/DVI)			
		VGA(VGA/OTHER)			
		Vivid	Standard	Pro	Mild
0	BNRL	0	0	0	0
8	BNRM	0	0	0	0

No.	Name	i.LINK(ex DV) for XBR(BS/CS/i.LINK(ex DV))							
		480i				480p			
		Vivid	Standard	Pro	Mild	Vivid	Standard	Pro	Mild
0	BNRL	0	0	0	0	0	0	0	0
8	BNRM	0	0	0	0	0	0	0	0

No.	Name	i.LINK(ex DV) for XBR(BS/CS/i.LINK(ex DV))							
		1080i				720p			
		Vivid	Standard	Pro	Mild	Vivid	Standard	Pro	Mild
0	BNRL	0	0	0	0	0	0	0	0
8	BNRM	0	0	0	0	0	0	0	0

No.	Name	BS/CS/i.LINK(ex DV)				i.LINK(DV)			
		Lower							
		Vivid	Standard	Pro	Mild	Vivid	Standard	Pro	Mild
0	BNRL	0	0	0	0	0	0	0	0
8	BNRM	0	0	0	0	0	0	0	0

No.	Name	ATSC(DTT/ATSC)							
		480i				480p			
		Vivid	Standard	Pro	Mild	Vivid	Standard	Pro	Mild
0	BNRL	0	0	0	0	0	0	0	0
8	BNRM	0	0	0	0	0	0	0	0

No.	Name	ATSC(DTT/ATSC)							
		1080i				720p			
		Vivid	Standard	Pro	Mild	Vivid	Standard	Pro	Mild
0	BNRL	0	0	0	0	0	0	0	0
8	BNRM	0	0	0	0	0	0	0	0

No.	Name	ATSC(DTT/ATSC)			
		Lower			
		Vivid	Standard	Pro	Mild
0	BNRL	0	0	0	0
8	BNRM	0	0	0	0

No.	Name	MS for XBR(DATA(ADD))							
		STILL(1080i)(480i)				MOVIE(CONT-PANEL)(OTHER)			
		Vivid	Standard	Pro	Mild	Vivid	Standard	Pro	Mild
0	BNRL	0	0	0	0	0	0	0	0
8	BNRM	0	0	0	0	0	0	0	0

No.	Name	MS for XBR(DATA(IND.))							
		MOVIE(LQ)(480i)				MOVIE(HQ)(OTHER)			
		Vivid	Standard	Pro	Mild	Vivid	Standard	Pro	Mild
0	BNRL	0	0	0	0	0	0	0	0
8	BNRM	0	0	0	0	0	0	0	0

Standards *2

No.	Name	BNRL = 0	BNRL = 1	BNRL = 2	BNRL = 3	BNRL = 4	BNRL = 5	BNRL = 6	BNRL = 7
1	EDL	2	2	2	2	2	2	2	2
2	LFL	2	2	2	2	2	2	2	2
3	DCT	2	2	2	2	2	2	2	2
4	BLEV	0	1	2	3	4	5	6	7
5	DNE	1	1	1	1	1	1	1	1
6	MRON	0	0	0	0	0	0	0	0
7	FMOD	0	0	0	0	0	0	0	0

CH-SET

Functionality	Data	Remarks
No. Name		
0 PKNO	*1	
1 CHNL	*1	
2 HOF5	*1	
3 PACK	*1	

Standards *1

No.	Name	PKNO = 0	PKNO = 1	PKNO = 2	PKNO = 3	PKNO = 4	PKNO = 5	PKNO = 6	PKNO = 7
0	PKNO	0	1	2	3	4	5	6	7
1	CHNL	0	0	0	0	0	0	0	0
2	HOF5	7	7	7	7	7	7	7	7
3	PACK	0	0	0	0	0	0	0	0

CCPS-1

Functionality		Data	Remarks
No.	Name		
0	SHPC	*1	
1	FUP2	*1	
2	YNR	*1	
3	CNR	*1	
4	SSHP	*1	
5	YEQ	*1	
6	SHF0	*1	
7	SECA	*2	
8	YCDL	*3	
9	YLEV	*3	
10	CLEV	*3	
11	SHUE	*4	
12	CEQ	*4	
13	CBPF	*4	
14	CBPA	*4	
15	KILV	*4	
16	APGA	*4	
17	NCOM	*4	

Standards *1

No.	Name	UV				Video			
		Vivid	Standard	Pro	Reserved	Vivid	Standard	Pro	Reserved
0	SHPC	0	0	0	0	0	0	0	0
1	FUP2	0	0	0	0	0	0	0	0
2	YNR	0	0	0	0	0	0	0	0
3	CNR	0	0	0	0	0	0	0	0
4	SSHP	4	4	4	7	7	7	7	7
5	YEQ	3	3	3	3	3	3	3	3
6	SHF0	1	1	1	1	1	1	1	1

No.	Name	BS(ANALOG)				DTT(ANALOG)			
		Vivid	Standard	Pro	Mild	Vivid	Standard	Pro	Mild
0	SHPC	0	0	0	0	0	0	0	0
1	FUP2	0	0	0	0	0	0	0	0
2	YNR	0	0	0	0	0	0	0	0
3	CNR	0	0	0	0	0	0	0	0
4	SSHP	7	7	7	7	7	7	7	7
5	YEQ	3	3	3	3	3	3	3	3
6	SHF0	1	1	1	1	1	1	1	1

No.	Name	MS for WE(MS/CNM)							
		STILL(1080i)				MOVIE(CONT-PANEL)			
		Vivid	Standard	Pro	Reserved	Vivid	Standard	Pro	Reserved
0	SHPC	0	0	0	0	0	0	0	0
1	FUP2	0	0	0	0	0	0	0	0
2	YNR	0	0	0	0	0	0	0	0
3	CNR	0	0	0	0	0	0	0	0
4	SSHP	7	7	7	7	7	7	7	7
5	YEQ	3	3	3	3	3	3	3	3
6	SHF0	1	1	1	1	1	1	1	1

No.	Name	MS for WE(MS/CNM)							
		MOVIE(LQ)				MOVIE(HQ)			
		Vivid	Standard	Pro	Reserved	Vivid	Standard	Pro	Mild
0	SHPC	0	0	0	0	0	0	0	0
1	FUP2	0	0	0	0	0	0	0	0
2	YNR	0	0	0	0	0	0	0	0
3	CNR	0	0	0	0	0	0	0	0
4	SSHP	7	7	7	7	7	7	7	7
5	YEQ	3	3	3	3	3	3	3	3
6	SHF0	1	1	1	1	1	1	1	1

Standards *2

No.	Name	UV	Video
7	SECA	10	10

No.	Name	COMPONENT/AVM(YCbCr)				AVM(RGB)/DVI				
		480i	480p	1080i	720p	480i	480p	1080i	720p	VGA/OTHER
7	SECA	0	0	0	0	0	0	0	0	0

No.	Name	BS/i.LINK					i.LINK(DV)
		480i	480p	1080i	720p	Lower	
7	SECA	0	0	0	0	0	0

No.	Name	DTT/ATSC				
		480i	480p	1080i	720p	Lower
7	SECA	0	0	0	0	0

No.	Name	DATA(ADD)		DATA(IND.)	
		480i	OTHER	480i	OTHER
7	SECA	0	0	0	0

Standards *3

No.	Name	UV	Video	BS(ANALOG)	DTT(ANALOG)	MS for WE(MS/CNM)			
						STILL(1080i)	MOVIE(CONT-PANEL)	MOVIE(LQ)	MOVIE(HQ)
8	YCDL	8	8	7	7	7	7	7	7
9	YLEV	175	175	194	194	128	128	128	160
10	CLEV	97	97	100	100	128	128	128	100

Standards *4

No.	Name	UV	Video	BS(ANALOG)	DTT(ANALOG)
11	SHUE	7	7	7	7
12	CEQ	3	0	0	0
13	CBPF	3	0	0	0
14	CBPA	0	1	1	1
15	KILV	2	2	2	2
16	APGA	0	0	0	0
17	NCOM	0	0	0	0

CCPS-2

Functionality		Data	Remarks
No.	Name		
0	SHPC	*1	

Standards *1

No.	Name	UV	Video1	Video2	Video3	Video4	BS	DTT
0	PACK	0	4	4	4	4	14	15

CCPS-3

Functionality		Data	Remarks
No.	Name		
0	ADIE	0	
1	APED	*1	
2	AATK	*2	
3	AHLD	*2	
4	AARE	*2	
5	AHIS	*2	
6	DCTR	*1	
7	DCTC	*3	
8	ID1W	*4	
9	WSSO	*4	
10	SLIC	*4	
11	AWOF	*5	
12	UPAR	*5	
13	UPTH	*5	
14	X149	*5	
15	DMST	*5	
16	INST	*5	
17	UPRL	*5	
18	OFSL	*5	
19	SLOF	*5	
20	FR43	*5	
21	FRWI	*5	
22	FRTI	*5	
23	LPFL	*5	
24	4CNT	*5	
25	REFP	*5	
26	REFM	*5	
27	AWSN	*5	
28	AWRE	*5	

Standards *1

No.	Name	ADIE = 1 Or MULTI(TWIN,FAVORITES)						
		480i (RF/Video/Component480i)						
		Vivid	Standard	Pro				Reserved
BLK Correction Off	BLK Correction L			BLK Correction M	BLK Correction H			
1	APED	2	1	0	1	2	3	1
6	DCTR	2	1	0	1	2	3	1

No.	Name	ADIE = 1 Or MULTI(TWIN,FAVORITES)						
		480p						
		Vivid	Standard	Pro				Reserved
BLK Correction Off	BLK Correction L			BLK Correction M	BLK Correction H			
1	APED	2	1	0	1	2	3	1
6	DCTR	2	1	0	1	2	3	1

No.	Name	ADIE = 1 Or MULTI(TWIN,FAVORITES)						
		1080i/60						
		Vivid	Standard	Pro				Reserved
BLK Correction Off	BLK Correction L			BLK Correction M	BLK Correction H			
1	APED	2	1	0	1	2	3	1
6	DCTR	2	1	0	1	2	3	1

No.	Name	ADIE = 1 Or MULTI(TWIN,FAVORITES)						
		720p/60						
		Vivid	Standard	Pro				Reserved
BLK Correction Off	BLK Correction L			BLK Correction M	BLK Correction H			
1	APED	2	1	0	1	2	3	1
6	DCTR	2	1	0	1	2	3	1

No.	Name	ADIE = 1 Or MULTI(TWIN,FAVORITES)						
		576i						
		Vivid	Standard	Pro				Reserved
BLK Correction Off	BLK Correction L			BLK Correction M	BLK Correction H			
1	APED	3	2	0	1	2	3	1
6	DCTR	3	2	0	1	2	3	1

No.	Name	ADIE = 1 Or MULTI(TWIN,FAVORITES)						
		576p						
		Vivid	Standard	Pro				Reserved
BLK Correction Off	BLK Correction L			BLK Correction M	BLK Correction H			
1	APED	3	2	0	1	2	3	1
6	DCTR	3	2	0	1	2	3	1

No.	Name	ADIE = 1 Or MULTI(TWIN,FAVORITES)						
		1080i/50						
		Vivid	Standard	Pro				Reserved
BLK Correction Off	BLK Correction L			BLK Correction M	BLK Correction H			
1	APED	3	2	0	1	2	3	1
6	DCTR	3	2	0	1	2	3	1

No.	Name	AD1E = 1 Or MULTI(TWIN,FAVORITES)						Reserved
		720p/50						
		Vivid	Standard	Pro				
BLK Correction Off	BLK Correction L			BLK Correction M	BLK Correction H			
1	APED	3	2	0	1	2	3	1
6	DCTR	3	2	0	1	2	3	1

Standards *2

No.	Name	APED = 0	APED = 1	APED = 2	APED = 3
2	AATK	2	2	2	2
3	AHLD	2	2	2	2
4	AARE	2	2	2	2
5	AHIS	0	0	0	0

Standards *3

No.	Name	DCTR = 0	DCTR = 1	DCTR = 2	DCTR = 3
7	DCTC	2	2	2	2

Standards *4

No.	Name	UV	Video1	Video2	Video3	Video4
8	ID1W	1	1	1	1	1
9	WSSO	0	0	0	0	0
10	SLIC	5	5	5	5	5

No.	Name	Video5(COMPONENT1)		Video6(COMPONENT2)		i.LINK/ATSC for XBR (AVM(YCb Cr))	
		480i	480p	480i	480p	480i	480p
8	ID1W	1	1	1	1	1	1
9	WSSO	0	0	0	0	0	0
10	SLIC	5	5	5	5	5	5

Standards *5

No.	Name	UV	Video1	Video2	Video3	Video4	Video5 480i(COMPONE NT1 480i)	Video6 480i(COMPONE NT2 480i)	i.LINK/ATSC for XBR 480i (AVM(YCbCr) 480i)
11	AWOF	0	0	0	0	0	0	0	0
12	UPAR	0	0	0	0	0	0	0	0
13	UPTH	0	0	0	0	0	0	0	0
14	X149	0	0	0	0	0	0	0	0
15	DMST	1	1	1	1	1	1	1	1
16	INST	0	0	0	0	0	0	0	0
17	UPRL	0	1	1	1	1	0	0	0
18	OFSL	0	0	0	0	0	0	0	0
19	SLOF	0	0	0	0	0	0	0	0
20	FR43	2	2	2	2	2	2	2	2
21	FRWI	2	2	2	2	2	2	2	2
22	FRTI	2	2	2	2	2	2	2	2
23	LPFL	1	1	1	1	1	1	1	1
24	4CNT	1	1	1	1	1	1	1	1
25	REFP	7	7	7	7	7	7	7	7
26	REFM	7	7	7	7	7	7	7	7
27	AWSN	0	0	0	0	0	0	0	0
28	AWRE	0	0	0	0	0	0	0	0

CCPS-4

Functionality		Data	Remarks
No.	Name		
0	CLKS	*1	
1	REFC	*1	
2	SYMD	*1	
3	SIFM	*1	
4	DTO1	*1	
5	DTO2	*1	
6	DTO3	*1	
7	PIX1	*1	
8	PIX2	*1	
9	VLN1	*1	
10	VLN2	*1	
11	SYSC	*1	
12	DSPC	*1	
13	PLLD	*1	
14	PLLR	*1	
15	DCLP	*1	
16	DCON	*1	
17	CO2P	*1	
18	CONV	*1	
19	HO2O	*1	
20	BLKM	*1	
21	OSDL	*1	
22	OSDR	*1	
23	CO2O	*1	
24	COLS	*1	
25	VFRQ	*1	
26	PLLS	*1	
27	PIFW	*1	
28	PIBW	*1	
29	PLL4	*1	
30	CDAD	*1	
31	CDAS	*1	
32	PLD1	*1	
33	PLTS	*1	
34	PLOL	*1	
35	YRND	*1	
36	CRND	*1	

Standards *1

No.	Name	UV		VIDEO				ANALOG COMPONENT				
		3-D	2-D	3-D	2-D	YC	YC	480i	480p	1080i	720p	VGA(DVI)
0	CLKS	0	0	0	0	0	0	0	0	0	0	0
1	REFC	1	1	1	1	1	1	1	1	1	1	1
2	SYMD	0	0	0	0	5	5	8	8	8	8	8
3	SIFM	0	0	0	0	0	0	0	2	3	4	6
4	DTO1	63	63	63	63	63	63	63	63	63	63	63
5	DTO2	254	254	254	254	254	254	254	254	254	254	254
6	DTO3	86	86	86	86	86	86	86	86	86	86	86
7	PIX1	0	0	0	0	0	0	0	0	0	0	49
8	PIX2	0	0	0	0	0	0	0	0	0	0	15
9	VLN1	0	0	0	0	0	0	0	0	0	0	2
10	VLN2	0	0	0	0	0	0	0	0	0	0	13
11	SYSC	1	1	1	1	1	1	1	0	0	0	0
12	DSPC	3	3	3	3	3	3	3	1	1	1	1
13	PLLD	0	0	0	0	0	0	0	0	0	0	0
14	PLLR	1	1	1	1	1	1	1	1	1	1	1
15	DCLP	2	2	2	2	2	2	2	2	2	2	2
16	DCON	0	0	0	0	0	0	0	0	0	0	0
17	CO2P	0	0	0	0	0	0	0	0	0	0	0
18	CONV	0	0	0	0	0	0	0	0	0	0	0
19	HO2O	1	1	1	1	1	1	1	0	0	0	0
20	BLKM	1	1	1	1	1	1	1	1	1	1	1
21	OSDL	3	3	3	3	3	3	3	3	3	3	3
22	OSDR	1	1	1	1	1	1	1	1	1	1	1
23	CO2O	1	1	1	1	1	1	1	0	0	0	0
24	COLS	0	0	0	0	0	0	0	0	0	0	0
25	VFRQ	3	3	3	3	3	3	3	3	3	3	3
26	PLLS	0	0	0	0	0	0	0	0	0	0	0
27	PIFW	0	0	0	0	0	0	0	0	0	0	0
28	PIBW	0	0	0	0	0	0	0	0	0	0	0
29	PLL4	0	0	0	0	0	0	0	0	0	0	0
30	CDAD	0	0	0	0	0	0	0	0	0	0	0
31	CDAS	0	0	0	0	0	0	0	0	0	0	0
32	PLD1	0	0	0	0	0	0	0	0	0	0	0
33	PLTS	0	0	0	0	0	0	0	0	0	0	0
34	PLOL	0	0	0	0	0	0	0	0	0	0	0
35	YRND	1	1	1	1	1	1	1	1	1	1	1
36	CRND	1	1	1	1	1	1	1	1	1	1	1

No.	Name	BS/DTT YC	BS/DTT DIGITAL COMPONENT				MS/CNM for WE
			480i	480p	1080i	720p	
0	CLKS	0	5	5	5	5	4
1	REFC	1	1	1	1	1	1
2	SYMD	5	14	14	14	14	12
3	SIFM	0	0	2	3	4	15
4	DT01	63	63	63	63	63	63
5	DT02	254	254	254	254	254	254
6	DT03	86	86	86	86	86	86
7	PIX1	0	0	0	0	0	255
8	PIX2	0	0	0	0	0	15
9	VLN1	0	0	0	0	0	0
10	VLN2	0	0	0	0	0	64
11	SYSC	1	1	0	0	0	0
12	DSPC	3	2	0	0	0	0
13	PLLD	0	0	0	0	0	0
14	PLLR	1	2	1	1	1	1
15	DCLP	2	2	2	2	2	2
16	DCON	0	0	0	0	0	0
17	CO2P	0	0	0	0	0	0
18	CONV	0	0	0	0	0	0
19	HO2O	0	0	0	0	0	0
20	BLKM	1	1	1	1	1	1
21	OSDL	3	3	3	3	3	3
22	OSDR	1	1	1	1	1	1
23	CO2O	0	0	0	0	0	0
24	COLS	0	0	0	0	0	0
25	VFRQ	3	3	3	3	3	3
26	PLLS	0	0	0	0	0	0
27	PIFW	0	0	0	0	0	0
28	PIBW	0	0	0	0	0	0
29	PLL4	0	0	0	0	0	0
30	CDAD	0	0	0	0	0	0
31	CDAS	0	0	0	0	0	0
32	PLD1	0	0	0	0	0	0
33	PLTS	0	0	0	0	0	0
34	PLOL	0	0	0	0	0	0
35	YRND	1	1	1	1	1	1
36	CRND	1	1	1	1	1	1

CCPS-5

Functionality		Data		Remarks
No.	Name	UV	Video	
0	NSS	8	8	
1	TESS	0	0	
2	NSC	15	15	
3	NSV	1	1	
4	STDH	2	2	
5	SHH	1	1	

CCPS-6

Functionality		Data		Remarks
No.	Name	UV	Video	
0	MC1	4	4	
1	MC2	3	3	
2	CR1	1	1	
3	CR2	1	1	
4	CR3	0	0	
5	CR4	1	1	
6	CCR	2	2	
7	CHED	2	2	
8	CVED	3	3	
9	CR5	4	4	
10	YFLT	4	4	
11	C3LE	1	1	
12	YMFH	3	3	
13	YMFV	1	1	
14	F2SW	0	0	
15	MO1	15	15	
16	MO2	3	3	
17	MNNR	1	1	
18	DTH	2	2	
19	DTV	2	2	
20	DT2D	2	2	
21	DTHP	3	3	
22	DTCR	4	4	
23	D2FC	3	3	
24	D2F	9	9	
25	D2F2	1	1	
26	D2FL	0	0	
27	DC	0	0	
28	CVFT	3	3	
29	HC2F	1	1	
30	MNSW	0	0	
31	MDYB	0	0	
32	LCBP	2	2	
33	BPSE	1	1	
34	CR2H	0	0	
35	IMPR	3	3	
36	IMPS	1	1	
37	IMPL	0	0	
38	PLPL	1	1	
39	MDYE	3	3	
40	PLCL	1	1	
41	BPL2	1	1	
42	HPL	1	1	
43	CVFP	0	0	
44	BPL3	7	7	
45	D2F3	2	2	
46	LPSW	1	1	
47	LCR	1	1	
48	F2CR	1	1	
49	YIR	1	1	
50	MOMO	0	0	

CCPS-7

Functionality		Data	Remarks
No.	Name		
0	SCTP	0	
1	CYBP	0	
2	Y2BP	0	
3	C2LE	1	
4	DTCN	1	
5	VEDL	3	
6	HP	2	
7	PNR	0	
8	NCDT	0	
9	H2DD	0	
10	THRU	0	
11	MCH	15	
12	MCV	1	
13	PEDS	0	
14	MMK	7	
15	MKAM	1	
16	HGLT	0	
17	TESL	0	
18	SDOF	1	
19	BPOF	1	
20	CIL	1	
21	CYV	0	
22	PAL3	0	

CCPS-8

Functionality		Data	Remarks
No.	Name		
0	VECR	*1	
1	VECL	*1	
2	VECN	*1	
3	VEGA	*1	

Standards *1

No.	Name	UV				Video			
		Vivid	Standard	Pro	Reserved	Vivid	Standard	Pro	Reserved
0	VECR	0	0	0	0	0	0	0	0
1	VECL	0	0	0	0	0	0	0	0
2	VECN	2	2	2	2	2	2	2	2
3	VEGA	0	0	0	0	0	0	0	0

No.	Name	BS(ANALOG)				DTT(ANALOG)			
		Vivid	Standard	Pro	Reserved	Vivid	Standard	Pro	Reserved
0	VECR	0	0	0	0	0	0	0	0
1	VECL	0	0	0	0	0	0	0	0
2	VECN	2	2	2	2	2	2	2	2
3	VEGA	0	0	0	0	0	0	0	0

CCPS-10

Functionality		Data	Remarks
No.	Name		
0	BNRL	*1	
1	EDL	*2	
2	LFL	*2	
3	DCT	*2	
4	BLEV	*2	
5	DNE	*2	
6	MRON	*2	
7	FMOD	*2	
8	BNRM	*1	

Standards *1

No.	Name	UV				Video			
		Vivid	Standard	Pro	Mild	Vivid	Standard	Pro	Mild
0	BNRL	0	0	0	0	0	0	0	0
8	BNRM	0	0	0	0	0	0	0	0

No.	Name	BS				DTT			
		Vivid	Standard	Pro	Mild	Vivid	Standard	Pro	Mild
0	BNRL	0	0	0	0	0	0	0	0
8	BNRM	0	0	0	0	0	0	0	0

No.	Name	MS for WE(MS/CNM)							
		STILL(1080i)				MOVIE(CONT-PANEL)			
		Vivid	Standard	Pro	Mild	Vivid	Standard	Pro	Mild
0	BNRL	0	0	0	0	0	0	0	0
8	BNRM	0	0	0	0	0	0	0	0

No.	Name	MS for WE(MS/CNM)							
		MOVIE(LQ)				M	OVIE(HQ)		
		Vivid	Standard	Pro	Mild	Vivid	Standard	Pro	Mild
0	BNRL	0	0	0	0	0	0	0	0
8	BNRM	0	0	0	0	0	0	0	0

Standards *2

No.	Name	BNRL = 0	BNRL = 1	BNRL = 2	BNRL = 3	BNRL = 4	BNRL = 5	BNRL = 6	BNRL = 7
1	EDL	2	2	2	2	2	2	2	2
2	LFL	2	2	2	2	2	2	2	2
3	DCT	2	2	2	2	2	2	2	2
4	BLEV	0	1	2	3	4	5	6	7
5	DNE	1	1	1	1	1	1	1	1
6	MRON	0	0	0	0	0	0	0	0
7	FMOD	0	0	0	0	0	0	0	0

DCP-INT

Functionality		Data	Remarks
No.	Name		
0	DENC	1	
1	DENG	0	
2	EO1C	1	
3	EO2C	1	
4	EO1H	0	
5	EO2H	1	
6	POFF	0	
7	O1TM	0	
8	YCFS	0	
9	RN8Y	0	
10	HINV	0	
11	VINV	0	
12	CDEM	1	
13	CPOL	0	
14	OFST	*1	
15	TCOF	0	
16	CINT	0	
17	RN8C	0	
18	DMTR	0	
19	MTRX	1	
20	OSDE	1	
21	MUX	1	
22	EXMT	1	
23	EXOF	0	
24	GON	1	
25	BON	1	
26	RON	1	
27	BKOF	1	
28	AGIW	0	
29	AGIB	0	
30	HFIN	0	
31	VFIN	0	
32	CFDM	0	
33	CFCP	0	
34	YFOF	0	
35	CFOF	0	
36	CFIP	0	
37	R8CF	0	
38	MATF	1	
39	GLMT	15	
40	WBSW	0	
41	OENG	0	
42	RFRM	1	
43	GHPL	1	
44	GVPL	1	
45	GBPL	1	

Standards *1

No.	Name	MS/MPEG 4	CNM(not MPEG4)	Others	Standby
14	OFST	0	0	0	0

DCP-OSD

Functionality		Data	Remarks
No.	Name		
0	HPL1	0	
1	VPL1	0	
2	HPL2	0	
3	VPL2	0	
4	HP1H	0	
5	HP1L	0	
6	HWD1	134	
7	CP1P	128	
8	CP1W	32	
9	HIN1	0	
10	WOF1	0	
11	O1WD	0	
12	WP1H	0	
13	WP1L	67	
14	WS1H	2	
15	WS1L	36	
16	RP1H	1	
17	RP1L	63	
18	RS1H	4	
19	RS1L	185	
20	MOD1	1	
21	GEN1	1	
22	GAI1	22	
23	YSD1	6	
24	YSW1	2	
25	YMD1	6	
26	YMW1	2	
27	GEN2	0	
28	GAI2	31	
29	YSD2	6	
30	YSW2	2	
31	YMD2	6	
32	YMW2	2	
33	MP1H	1	
34	MP1L	64	
35	MS1H	2	
36	MS1L	171	
37	FP1H	2	
38	FP1L	195	
39	FS1H	3	
40	FS1L	150	

DCP-BLK

Functionality		Data	Remarks
No.	Name		
0	PSCL	*1	
1	LHBH	*1	
2	RHBH	*1	
3	LHBL	*1	
4	RHBL	*1	
5	UVBH	0	
6	UVBL	3	
7	UVBL	22	
8	LVBL	22	
9	LHPH	*1	
10	RHPH	*1	
11	LHPL	*1	
12	RHPL	*1	
13	UVPH	0	
14	LVPH	2	
15	UVPL	75	
16	LVPL	126	
17	LHKH	*1	
18	RHKL	*1	
19	LHKL	*1	
20	RHKH	*1	
21	UVKH	0	
22	LVKH	3	
23	UVKL	8	
24	LVKL	36	

Standards *1

No.	Name	Normal	Wide
0	PSCL	186	134
1	LHBH	1	0
2	RHBH	5	6
3	LHBL	166	232
4	RHBL	128	62
9	LHPH	1	1
10	RHPH	5	5
11	LHPL	230	80
12	RHPL	80	224
17	LHKH	0	0
18	RHKL	6	6
19	LHKL	217	217
20	RHKH	95	95

DCP-ADJ1

Functionality		Data	Remarks
No.	Name		
0	CBOF	*1	
1	CROF	*1	
2	SCON	*1	
3	RDRV	*2	
4	GDRV	*2	
5	BDRV	*2	
6	RCUT	*2	
7	GCUT	*2	
8	BCUT	*2	
9	SBRT	132	
10	SPIC	63	
11	SCOL	*1	
12	SCNF	128	
13	SCLF	128	

Standards *1

No.	Name	UV	Video	Component	Component	Component	Component
				(480i)	(480p)	(1080i)	(720p)
0	CBOF	130	128	130	134	129	129
1	CROF	130	128	130	133	130	130
2	SCON	175	175	175	185	185	185
11	SCOL	185	185	170	185	185	185

No.	Name	ATSC	ATSC	ATSC	ATSC	DTT/ATSC	DTT/ATSC
		(480i)	(480p)	(1080i)	(720p)	(Data)	(Lower)
0	CBOF	128	128	128	128	128	128
1	CROF	128	128	128	128	128	128
2	SCON	175	185	185	185	185	170
11	SCOL	170	185	185	185	176	176

No.	Name	DVI	DVI	DVI	DVI	DVI
		(480i)	(480p)	(1080i)	(720p)	(VGA etc)
0	CBOF	129	128	124	124	124
1	CROF	129	128	125	124	122
2	SCON	175	185	185	185	185
11	SCOL	170	185	185	185	185

No.	Name	iLINK	iLINK (480p)	iLINK (1080i)	iLINK (720p)	BS/CS-d/	BS/CS-d/
		(480i Except DV)				iLINK (Data)	iLINK (Lower)
0	CBOF	128	128	128	128	128	128
1	CROF	128	128	128	128	128	128
2	SCON	175	185	185	185	185	185
11	SCOL	170	185	185	185	176	176

No.	Name	iLINK(DV)	Memory Stick	Memory Stick	MS/CNM	Memory Stick	Twin/Freeze/
			(Still)	(Movie:Console)	MOVIE(HQ)	(Movie:Lower)	INDEX/FAVORITE
0	CBOF	126	128	128	128	128	128
1	CROF	126	128	128	128	128	128
2	SCON	175	126	126	100	126	175
11	SCOL	170	125	125	176	125	170

Standards *2

No.	Name	Color Temperature			
		4(Used)	3(Reserved)	2(Reserved)	1(Reserved)
3	RDRV	140	140	140	140
4	GDRV	140	140	140	140
5	BDRV	140	140	140	140
6	RCUT	255	255	255	255
7	GCUT	255	255	255	255
8	BCUT	255	255	255	255

DCP-ADJ2

Functionality No.	Name	Data	Remarks
0	SHOF	*1	
1	SHF0	*1	
2	SHPC	*1	
3	PROV	*1	
4	HFBT	*1	
5	ULTI	*1	
6	LTSL	*2	
7	LTLV	*2	
8	LTDL	*2	
9	LTMD	*2	
10	LTCD	*2	
11	UCTI	*1	
12	CTLV	*3	
13	CTDL	*3	
14	CTMD	*3	
15	CTCR	*3	
16	MIDE	*1	
17	APCD	*1	
18	NRLV	*1	

Standards *1

No.	Name	Normal									
		UV					Video				
		VIVID	STANDARD MILD OFF	STANDARD MILD ON	PRO MILD OFF	PRO MILD ON	VIVID	STANDARD MILD OFF	STANDARD MILD ON	PRO MILD OFF	PRO MILD ON
0	SHOF	31	31	31	31	20	23	23	23	23	23
1	SHF0	13	13	13	13	13	13	13	13	13	13
2	SHPC	6	6	6	6	6	4	4	4	4	4
3	PROV	8	8	8	8	8	8	8	8	8	8
4	HFBT	0	0	0	0	0	0	0	0	0	0
5	ULTI	0	0	0	0	0	0	0	0	0	0
11	UCTI	0	0	0	0	0	0	0	0	0	0
16	MIDE	7	6	6	4	4	11	10	10	8	8
17	APCD	2	2	2	2	2	2	2	2	2	2
18	NRLV	0	0	0	0	0	6	5	7	0	0

No.	Name	Normal									
		ATSC (480i)					ATSC (480p)				
		VIVID	STANDARD MILD OFF	STANDARD MILD ON	PRO MILD OFF	PRO MILD ON	VIVID	STANDARD MILD OFF	STANDARD MILD ON	PRO MILD OFF	PRO MILD ON
0	SHOF	31	31	20	20	10	31	31	20	20	10
1	SHF0	14	14	14	14	14	13	13	13	13	13
2	SHPC	0	0	0	0	0	0	0	0	0	0
3	PROV	8	8	8	8	8	8	8	8	8	8
4	HFBT	0	0	0	0	0	0	0	0	0	0
5	ULTI	0	0	0	0	0	0	0	0	0	0
11	UCTI	6	6	0	0	0	6	6	0	0	0
16	MIDE	19	18	18	16	16	23	22	22	20	20
17	APCD	2	2	2	2	2	2	2	2	2	2
18	NRLV	6	5	7	0	0	6	5	7	0	0

No.	Name	Normal									
		ATSC (1080i)					ATSC (720p)				
		VIVID	STANDARD MILD OFF	STANDARD MILD ON	PRO MILD OFF	PRO MILD ON	VIVID	STANDARD MILD OFF	STANDARD MILD ON	PRO MILD OFF	PRO MILD ON
0	SHOF	31	31	20	31	20	31	31	20	31	20
1	SHF0	15	15	15	15	15	15	15	15	15	15
2	SHPC	0	0	0	0	0	0	0	0	0	0
3	PROV	8	8	8	8	8	8	8	8	8	8
4	HFBT	0	0	0	0	0	0	0	0	0	0
5	ULTI	0	0	0	0	0	0	0	0	0	0
11	UCTI	0	0	0	0	0	0	0	0	0	0
16	MIDE	27	26	26	24	24	31	30	30	28	28
17	APCD	2	2	2	2	2	2	2	2	2	2
18	NRLV	5	5	6	0	0	5	5	6	0	0

No.	Name	Normal DTT/ATSC (LOWER)				
		VIVID	STANDARD MILD OFF	STANDARD MILD ON	PRO MILD OFF	PRO MILD ON
		0	SHOF	31	31	31
1	SHF0	15	15	15	15	15
2	SHPC	0	0	0	0	0
3	PROV	8	8	8	8	8
4	HFBT	15	15	15	15	15
5	ULTI	0	0	0	0	0
11	UCTI	6	6	6	6	6
16	MIDE	31	31	31	31	31
17	APCD	2	2	2	2	2
18	NRLV	6	6	6	6	6

No.	Name	Normal									
		i.LINK (480i : Except DV)					i.LINK (480p)				
		VIVID	STANDARD MILD OFF	STANDARD MILD ON	PRO MILD OFF	PRO MILD ON	VIVID	STANDARD MILD OFF	STANDARD MILD ON	PRO MILD OFF	PRO MILD ON
0	SHOF	31	31	20	20	10	31	31	20	20	10
1	SHF0	14	14	14	14	14	13	13	13	13	13
2	SHPC	0	0	0	0	0	0	0	0	0	0
3	PROV	8	8	8	8	8	8	8	8	8	8
4	HFBT	0	0	0	0	0	0	0	0	0	0
5	ULTI	0	0	0	0	0	0	0	0	0	0
11	UCTI	6	6	0	0	0	6	6	0	0	0
16	MIDE	35	34	34	32	32	39	38	38	36	36
17	APCD	2	2	2	2	2	2	2	2	2	2
18	NRLV	6	5	7	0	0	6	5	7	0	0

No.	Name	Normal									
		i.LINK (1080i)					i.LINK (720p)				
		VIVID	STANDARD MILD OFF	STANDARD MILD ON	PRO MILD OFF	PRO MILD ON	VIVID	STANDARD MILD OFF	STANDARD MILD ON	PRO MILD OFF	PRO MILD ON
0	SHOF	31	31	20	31	20	31	31	20	31	20
1	SHF0	15	15	15	15	15	15	15	15	15	15
2	SHPC	0	0	0	0	0	0	0	0	0	0
3	PROV	8	8	8	8	8	8	8	8	8	8
4	HFBT	0	0	0	0	0	0	0	0	0	0
5	ULTI	0	0	0	0	0	0	0	0	0	0
11	UCTI	0	0	0	0	0	0	0	0	0	0
16	MIDE	43	42	42	40	40	47	46	46	44	44
17	APCD	2	2	2	2	2	2	2	2	2	2
18	NRLV	5	5	6	0	0	5	5	6	0	0

No.	Name	Normal									
		BS/CS-d/i.LINK (LOWER)					i.LINK(DV)				
		VIVID	STANDARD MILD OFF	STANDARD MILD ON	PRO MILD OFF	PRO MILD ON	VIVID	STANDARD MILD OFF	STANDARD MILD ON	PRO MILD OFF	PRO MILD ON
0	SHOF	31	31	31	31	31	31	31	20	20	10
1	SHF0	15	15	15	15	15	14	14	14	14	14
2	SHPC	0	0	0	0	0	0	0	0	0	0
3	PROV	8	8	8	8	8	8	8	8	8	8
4	HFBT	15	15	15	15	15	15	15	15	15	15
5	ULTI	0	0	0	0	0	0	0	0	0	0
11	UCTI	6	6	6	6	6	0	0	0	0	0
16	MIDE	31	31	31	31	31	15	14	14	12	12
17	APCD	2	2	2	2	2	2	2	2	2	2
18	NRLV	6	6	6	6	6	5	5	5	5	5

No.	Name	Normal									
		IND. DATA (480i)					IND. DATA (ex 480i)				
		VIVID	STANDARD MILD OFF	STANDARD MILD ON	PRO MILD OFF	PRO MILD ON	VIVID	STANDARD MILD OFF	STANDARD MILD ON	PRO MILD OFF	PRO MILD ON
0	SHOF	31	31	31	31	31	20	31	20	31	31
1	SHF0	15	15	15	15	15	15	15	15	15	15
2	SHPC	0	0	0	0	0	0	0	0	0	0
3	PROV	8	8	8	8	8	8	8	8	8	8
4	HFBT	15	15	15	15	15	15	15	15	15	15
5	ULTI	0	0	0	0	0	0	0	0	0	0
11	UCTI	6	6	6	6	6	0	0	0	6	6
16	MIDE	31	31	31	31	31	14	12	12	31	31
17	APCD	2	2	2	2	2	2	2	2	2	2
18	NRLV	6	6	6	6	6	5	5	5	6	6

No.	Name	Normal									
		ADD DATA (480i)					ADD DATA (ex 480i)				
		VIVID	STANDARD MILD OFF	STANDARD MILD ON	PRO MILD OFF	PRO MILD ON	VIVID	STANDARD MILD OFF	STANDARD MILD ON	PRO MILD OFF	PRO MILD ON
0	SHOF	31	31	31	20	31	20	31	31	31	31
1	SHF0	15	15	15	15	15	15	15	15	15	15
2	SHPC	0	0	0	0	0	0	0	0	0	0
3	PROV	8	8	8	8	8	8	8	8	8	8
4	HFBT	15	15	15	15	15	15	15	15	15	15
5	ULTI	0	0	0	0	0	0	0	0	0	0
11	UCTI	6	6	6	0	0	0	6	6	6	6
16	MIDE	31	31	31	14	12	12	31	31	31	31
17	APCD	2	2	2	2	2	2	2	2	2	2
18	NRLV	6	6	6	5	5	5	6	6	6	6

No.	Name	Normal									
		Component (480i)					Component (480p)				
		VIVID	STANDARD MILD OFF	STANDARD MILD ON	PRO MILD OFF	PRO MILD ON	VIVID	STANDARD MILD OFF	STANDARD MILD ON	PRO MILD OFF	PRO MILD ON
0	SHOF	31	31	20	20	10	31	31	20	20	10
1	SHF0	14	14	14	14	14	13	13	13	13	13
2	SHPC	0	0	0	0	0	0	0	0	0	0
3	PROV	8	8	8	8	8	8	8	8	8	8
4	HFBT	0	0	0	0	0	0	0	0	0	0
5	ULTI	0	0	0	0	0	0	0	0	0	0
11	UCTI	6	6	0	0	0	6	6	0	0	0
16	MIDE	51	50	50	48	48	55	54	54	52	52
17	APCD	2	2	2	2	2	2	2	2	2	2
18	NRLV	6	5	7	0	0	6	5	7	0	0

No.	Name	Normal									
		Component (1080i)					Component (720p)				
		VIVID	STANDARD MILD OFF	STANDARD MILD ON	PRO MILD OFF	PRO MILD ON	VIVID	STANDARD MILD OFF	STANDARD MILD ON	PRO MILD OFF	PRO MILD ON
0	SHOF	31	31	20	31	20	31	31	20	31	20
1	SHF0	15	15	15	15	15	15	15	15	15	15
2	SHPC	0	0	0	0	0	0	0	0	0	0
3	PROV	8	8	8	8	8	8	8	8	8	8
4	HFBT	0	0	0	0	0	0	0	0	0	0
5	ULTI	0	0	0	0	0	0	0	0	0	0
11	UCTI	0	0	0	0	0	0	0	0	0	0
16	MIDE	59	58	58	56	56	63	62	62	60	60
17	APCD	2	2	2	2	2	2	2	2	2	2
18	NRLV	5	5	6	0	0	5	5	6	0	0

No.	Name	Normal									
		DVI (480i)					DVI (480p)				
		VIVID	STANDARD MILD OFF	STANDARD MILD ON	PRO MILD OFF	PRO MILD ON	VIVID	STANDARD MILD OFF	STANDARD MILD ON	PRO MILD OFF	PRO MILD ON
0	SHOF	31	31	20	20	10	31	31	20	20	10
1	SHF0	14	14	14	14	14	13	13	13	13	13
2	SHPC	0	0	0	0	0	0	0	0	0	0
3	PROV	8	8	8	8	8	8	8	8	8	8
4	HFBT	0	0	0	0	0	0	0	0	0	0
5	ULTI	0	0	0	0	0	0	0	0	0	0
11	UCTI	6	6	0	0	0	6	6	0	0	0
16	MIDE	67	66	66	64	64	71	70	70	68	68
17	APCD	2	2	2	2	2	2	2	2	2	2
18	NRLV	6	5	7	0	0	6	5	7	0	0

No.	Name	Normal									
		DVI (1080i)					DVI (720p)				
		VIVID	STANDARD MILD OFF	STANDARD MILD ON	PRO MILD OFF	PRO MILD ON	VIVID	STANDARD MILD OFF	STANDARD MILD ON	PRO MILD OFF	PRO MILD ON
0	SHOF	31	31	20	31	20	31	31	20	31	20
1	SHF0	15	15	15	15	15	15	15	15	15	15
2	SHPC	0	0	0	0	0	0	0	0	0	0
3	PROV	8	8	8	8	8	8	8	8	8	8
4	HFBT	0	0	0	0	0	0	0	0	0	0
5	ULTI	0	0	0	0	0	0	0	0	0	0
11	UCTI	0	0	0	0	0	0	0	0	0	0
16	MIDE	75	74	74	72	72	79	78	78	76	76
17	APCD	2	2	2	2	2	2	2	2	2	2
18	NRLV	5	5	6	0	0	5	5	6	0	0

No.	Name	Normal				
		DVI (VGA etc)				
		VIVID	STANDARD MILD OFF	STANDARD MILD ON	PRO MILD OFF	PRO MILD ON
0	SHOF	31	31	20	20	10
1	SHF0	13	13	13	13	13
2	SHPC	0	0	0	0	0
3	PROV	8	8	8	8	8
4	HFBT	0	0	0	0	0
5	ULTI	0	0	0	0	0
11	UCTI	6	6	0	0	0
16	MIDE	83	82	82	80	80
17	APCD	2	2	2	2	2
18	NRLV	6	5	7	0	0

No.	Name	Normal									
		MS (STILL)					MS (MOVIE(CONT-PANEL))				
		VIVID	STANDARD MILD OFF	STANDARD MILD ON	PRO MILD OFF	PRO MILD ON	VIVID	STANDARD MILD OFF	STANDARD MILD ON	PRO MILD OFF	PRO MILD ON
0	SHOF	31	31	10	31	10	31	31	10	31	10
1	SHFO	15	15	15	15	15	15	15	15	15	15
2	SHPC	0	0	0	0	0	0	0	0	0	0
3	PROV	8	8	8	8	8	8	8	8	8	8
4	HFBT	0	0	0	0	0	0	0	0	0	0
5	ULTI	0	0	0	0	0	0	0	0	0	0
11	UCTI	0	0	0	0	0	0	0	0	0	0
16	MIDE	87	86	86	84	84	91	90	90	88	88
17	APCD	2	2	2	2	2	2	2	2	2	2
18	NRLV	5	5	6	0	0	5	5	6	0	0

No.	Name	Normal									
		MS (MOVIE(HQ))					MS (MOVIE(LQ))				
		VIVID	STANDARD MILD OFF	STANDARD MILD ON	PRO MILD OFF	PRO MILD ON	VIVID	STANDARD MILD OFF	STANDARD MILD ON	PRO MILD OFF	PRO MILD ON
0	SHOF	31	31	10	31	31	31	31	10	31	10
1	SHFO	15	15	15	15	15	15	15	15	15	15
2	SHPC	0	0	0	0	0	0	0	0	0	0
3	PROV	8	8	8	8	8	8	8	8	8	8
4	HFBT	0	0	0	0	0	0	0	0	0	0
5	ULTI	0	0	0	0	0	0	0	0	0	0
11	UCTI	0	0	0	0	0	0	0	0	0	0
16	MIDE	95	84	84	91	90	99	98	98	96	96
17	APCD	2	2	2	2	2	2	2	2	2	2
18	NRLV	5	5	6	5	5	5	5	6	0	0

No.	Name	Full/Widezoom/Zoom									
		UV					Video				
		VIVID	STANDARD MILD OFF	STANDARD MILD ON	PRO MILD OFF	PRO MILD ON	VIVID	STANDARD MILD OFF	STANDARD MILD ON	PRO MILD OFF	PRO MILD ON
0	SHOF	50	45	38	38	31	39	28	28	28	28
1	SHFO	13	13	13	13	13	13	13	13	13	13
2	SHPC	6	6	6	6	6	4	4	4	4	4
3	PROV	8	8	8	8	8	8	8	8	8	8
4	HFBT	0	0	0	0	0	0	0	0	0	0
5	ULTI	2	0	0	0	0	1	0	0	0	0
11	UCTI	6	6	6	6	6	6	6	6	6	6
16	MIDE	7	6	6	4	4	11	10	10	8	8
17	APCD	2	2	2	2	2	2	2	2	2	2
18	NRLV	6	0	0	0	0	6	5	7	0	0

No.	Name	Full/Widezoom/Zoom									
		ATSC (480i)					ATSC (480p)				
		VIVID	STANDARD MILD OFF	STANDARD MILD ON	PRO MILD OFF	PRO MILD ON	VIVID	STANDARD MILD OFF	STANDARD MILD ON	PRO MILD OFF	PRO MILD ON
0	SHOF	31	31	20	20	10	41	41	20	31	10
1	SHFO	14	14	14	14	14	13	13	13	13	13
2	SHPC	0	0	0	0	0	0	0	0	0	0
3	PROV	8	8	8	8	8	8	8	8	8	8
4	HFBT	15	15	0	0	0	15	15	0	0	0
5	ULTI	1	0	0	0	0	1	0	0	0	0
11	UCTI	6	6	0	0	0	6	6	0	0	0
16	MIDE	19	18	18	16	16	23	22	22	20	20
17	APCD	2	2	2	2	2	2	2	2	2	2
18	NRLV	6	5	7	0	0	6	5	7	0	0

No.	Name	Full/Widezoom/Zoom									
		ATSC (1080i)					ATSC (720p)				
		VIVID	STANDARD MILD OFF	STANDARD MILD ON	PRO MILD OFF	PRO MILD ON	VIVID	STANDARD MILD OFF	STANDARD MILD ON	PRO MILD OFF	PRO MILD ON
0	SHOF	31	31	20	31	20	31	31	20	31	20
1	SHFO	15	15	15	15	15	15	15	15	15	15
2	SHPC	0	0	0	0	0	0	0	0	0	0
3	PROV	8	8	8	8	8	8	8	8	8	8
4	HFBT	15	15	0	0	0	15	15	15	15	15
5	ULTI	0	0	0	0	0	0	0	0	0	0
11	UCTI	0	0	0	0	0	0	0	0	0	0
16	MIDE	27	26	26	24	24	31	30	30	28	28
17	APCD	2	2	2	2	2	2	2	2	2	2
18	NRLV	5	5	6	0	0	5	5	6	0	0

No.	Name	ex NORMAL				
		DTT/ATSC (LOWER)				
		VIVID	STANDARD MILD OFF	STANDARD MILD ON	PRO MILD OFF	PRO MILD ON
0	SHOF	31	31	20	31	31
1	SHF0	15	15	15	15	15
2	SHPC	0	0	0	0	0
3	PROV	8	8	8	8	8
4	HFBT	15	0	0	15	15
5	ULTI	0	0	0	0	0
11	UCTI	6	0	0	0	0
16	MIDE	31	24	24	31	30
17	APCD	2	2	2	2	2
18	NRLV	6	6	6	5	5

No.	Name	Full/Widezoom/Zoom									
		i.LINK (480i : Except DV)					i.LINK (480p)				
		VIVID	STANDARD MILD OFF	STANDARD MILD ON	PRO MILD OFF	PRO MILD ON	VIVID	STANDARD MILD OFF	STANDARD MILD ON	PRO MILD OFF	PRO MILD ON
0	SHOF	31	31	20	20	10	41	41	20	31	10
1	SHF0	14	14	14	14	14	13	13	13	13	13
2	SHPC	0	0	0	0	0	0	0	0	0	0
3	PROV	8	8	8	8	8	8	8	8	8	8
4	HFBT	15	15	0	0	0	15	15	0	0	0
5	ULTI	1	0	0	0	0	1	0	0	0	0
11	UCTI	6	6	0	0	0	6	6	0	0	0
16	MIDE	35	34	34	32	32	39	38	38	36	36
17	APCD	2	2	2	2	2	2	2	2	2	2
18	NRLV	6	5	7	0	0	6	5	7	0	0

No.	Name	Full/Widezoom/Zoom									
		i.LINK (1080i)					i.LINK (720p)				
		VIVID	STANDARD MILD OFF	STANDARD MILD ON	PRO MILD OFF	PRO MILD ON	VIVID	STANDARD MILD OFF	STANDARD MILD ON	PRO MILD OFF	PRO MILD ON
0	SHOF	31	31	20	31	20	31	31	20	31	20
1	SHF0	15	15	15	15	15	15	15	15	15	15
2	SHPC	0	0	0	0	0	0	0	0	0	0
3	PROV	8	8	8	8	8	8	8	8	8	8
4	HFBT	15	15	0	0	0	15	15	15	15	15
5	ULTI	0	0	0	0	0	0	0	0	0	0
11	UCTI	0	0	0	0	0	0	0	0	0	0
16	MIDE	43	42	42	40	40	47	46	46	44	44
17	APCD	2	2	2	2	2	2	2	2	2	2
18	NRLV	5	5	6	0	0	5	5	6	0	0

No.	Name	Full/Widezoom/Zoom									
		BS/CS-d/i.LINK (LOWER)					i.LINK(DV)				
		VIVID	STANDARD MILD OFF	STANDARD MILD ON	PRO MILD OFF	PRO MILD ON	VIVID	STANDARD MILD OFF	STANDARD MILD ON	PRO MILD OFF	PRO MILD ON
0	SHOF	31	31	20	31	31	31	31	20	20	10
1	SHF0	15	15	15	15	15	14	14	14	14	14
2	SHPC	0	0	0	0	0	0	0	0	0	0
3	PROV	8	8	8	8	8	8	8	8	8	8
4	HFBT	15	0	0	15	15	15	15	15	15	15
5	ULTI	0	0	0	0	0	1	0	0	0	0
11	UCTI	6	0	0	0	0	6	6	0	0	0
16	MIDE	31	40	40	47	46	15	14	14	12	12
17	APCD	2	2	2	2	2	2	2	2	2	2
18	NRLV	6	6	6	5	5	5	5	5	5	5

No.	Name	ex NORMAL									
		IND. DATA (480i)					IND. DATA (ex 480i)				
		VIVID	STANDARD MILD OFF	STANDARD MILD ON	PRO MILD OFF	PRO MILD ON	VIVID	STANDARD MILD OFF	STANDARD MILD ON	PRO MILD OFF	PRO MILD ON
0	SHOF	31	31	31	31	31	20	31	20	20	31
1	SHF0	15	15	15	15	15	15	15	15	15	15
2	SHPC	0	0	0	0	0	0	0	0	0	0
3	PROV	8	8	8	8	8	8	8	8	8	8
4	HFBT	15	15	15	15	15	15	15	15	15	15
5	ULTI	0	0	0	0	0	0	0	0	0	0
11	UCTI	6	0	0	0	0	0	0	0	0	0
16	MIDE	31	47	46	15	14	14	12	12	12	47
17	APCD	2	2	2	2	2	2	2	2	2	2
18	NRLV	6	6	6	6	6	6	6	6	6	6

No.	Name	ex NORMAL									
		ADD DATA (480i)					ADD DATA (ex 480i)				
		VIVID	STANDARD MILD OFF	STANDARD MILD ON	PRO MILD OFF	PRO MILD ON	VIVID	STANDARD MILD OFF	STANDARD MILD ON	PRO MILD OFF	PRO MILD ON
0	SHOF	31	31	31	20	31	20	31	31	31	31
1	SHF0	15	15	15	15	15	15	15	15	15	15
2	SHPC	0	0	0	0	0	0	0	0	0	0
3	PROV	8	8	8	8	8	8	8	8	8	8
4	HFBT	15	15	15	15	15	15	15	15	15	15
5	ULTI	0	0	0	0	0	0	0	0	0	0
11	UCTI	6	0	0	0	0	0	0	0	0	0
16	MIDE	31	15	14	14	12	12	47	47	47	15
17	APCD	2	2	2	2	2	2	2	2	2	2
18	NRLV	6	5	5	5	5	5	6	6	6	5

No.	Name	Full/Widezoom/Zoom									
		Component (480i)					Component (480p)				
		VIVID	STANDARD MILD OFF	STANDARD MILD ON	PRO MILD OFF	PRO MILD ON	VIVID	STANDARD MILD OFF	STANDARD MILD ON	PRO MILD OFF	PRO MILD ON
0	SHOF	31	31	20	20	10	41	41	20	31	10
1	SHF0	14	14	14	14	14	13	13	13	13	13
2	SHPC	0	0	0	0	0	0	0	0	0	0
3	PROV	8	8	8	8	8	8	8	8	8	8
4	HFBT	15	15	0	0	0	15	15	0	0	0
5	ULTI	1	0	0	0	0	1	0	0	0	0
11	UCTI	6	6	0	0	0	6	6	0	0	0
16	MIDE	51	50	50	48	48	55	54	54	52	52
17	APCD	2	2	2	2	2	2	2	2	2	2
18	NRLV	6	5	7	0	0	6	5	7	0	0

No.	Name	Full/Widezoom/Zoom									
		Component (1080i)					Component (720p)				
		VIVID	STANDARD MILD OFF	STANDARD MILD ON	PRO MILD OFF	PRO MILD ON	VIVID	STANDARD MILD OFF	STANDARD MILD ON	PRO MILD OFF	PRO MILD ON
0	SHOF	31	31	20	31	20	31	31	20	31	20
1	SHF0	15	15	15	15	15	15	15	15	15	15
2	SHPC	0	0	0	0	0	0	0	0	0	0
3	PROV	8	8	8	8	8	8	8	8	8	8
4	HFBT	15	15	0	0	0	15	15	15	15	15
5	ULTI	0	0	0	0	0	0	0	0	0	0
11	UCTI	0	0	0	0	0	0	0	0	0	0
16	MIDE	59	58	58	56	56	63	62	62	60	60
17	APCD	2	2	2	2	2	2	2	2	2	2
18	NRLV	5	5	6	0	0	5	5	6	0	0

No.	Name	Full/Widezoom/Zoom									
		DVI (480i)					DVI (480p)				
		VIVID	STANDARD MILD OFF	STANDARD MILD ON	PRO MILD OFF	PRO MILD ON	VIVID	STANDARD MILD OFF	STANDARD MILD ON	PRO MILD OFF	PRO MILD ON
0	SHOF	31	31	20	20	10	41	41	20	31	10
1	SHF0	14	14	14	14	14	13	13	13	13	13
2	SHPC	0	0	0	0	0	0	0	0	0	0
3	PROV	8	8	8	8	8	8	8	8	8	8
4	HFBT	15	15	0	0	0	15	15	0	0	0
5	ULTI	1	0	0	0	0	1	0	0	0	0
11	UCTI	6	6	0	0	0	6	6	0	0	0
16	MIDE	67	66	66	64	64	71	70	70	68	68
17	APCD	2	2	2	2	2	2	2	2	2	2
18	NRLV	6	5	7	0	0	6	5	7	0	0

No.	Name	Full/Widezoom/Zoom									
		DVI (1080i)					DVI (720p)				
		VIVID	STANDARD MILD OFF	STANDARD MILD ON	PRO MILD OFF	PRO MILD ON	VIVID	STANDARD MILD OFF	STANDARD MILD ON	PRO MILD OFF	PRO MILD ON
0	SHOF	31	31	20	31	20	31	31	20	31	20
1	SHF0	15	15	15	15	15	15	15	15	15	15
2	SHPC	0	0	0	0	0	0	0	0	0	0
3	PROV	8	8	8	8	8	8	8	8	8	8
4	HFBT	15	15	0	0	0	15	15	15	15	15
5	ULTI	0	0	0	0	0	0	0	0	0	0
11	UCTI	0	0	0	0	0	0	0	0	0	0
16	MIDE	75	74	74	72	72	79	78	78	76	76
17	APCD	2	2	2	2	2	2	2	2	2	2
18	NRLV	5	5	6	0	0	5	5	6	0	0

No.	Name	Full/Widezoom/Zoom				
		DVI (VGA etc)				
		VIVID	STANDARD MILD OFF	STANDARD MILD ON	PRO MILD OFF	PRO MILD ON
0	SHOF	41	41	20	31	10
1	SHF0	13	13	13	13	13
2	SHPC	0	0	0	0	0
3	PROV	8	8	8	8	8
4	HFBT	15	15	0	0	0
5	ULTI	1	0	0	0	0
11	UCTI	6	6	0	0	0
16	MIDE	83	82	82	80	80
17	APCD	2	2	2	2	2
18	NRLV	6	5	7	0	0

No.	Name	Full/Widezoom/Zoom									
		MS (STILL)					MS (MOVIE(CONT-PANEL))				
		VIVID	STANDARD MILD OFF	STANDARD MILD ON	PRO MILD OFF	PRO MILD ON	VIVID	STANDARD MILD OFF	STANDARD MILD ON	PRO MILD OFF	PRO MILD ON
0	SHOF	31	31	10	31	10	31	31	10	31	10
1	SHF0	15	15	15	15	15	15	15	15	15	15
2	SHPC	0	0	0	0	0	0	0	0	0	0
3	PROV	8	8	8	8	8	8	8	8	8	8
4	HFBT	0	0	0	0	0	0	0	0	0	0
5	ULTI	0	0	0	0	0	0	0	0	0	0
11	UCTI	0	0	0	0	0	0	0	0	0	0
16	MIDE	87	86	86	84	84	91	90	90	88	88
17	APCD	2	2	2	2	2	2	2	2	2	2
18	NRLV	5	5	6	0	0	5	5	6	0	0

No.	Name	Full/Widezoom/Zoom									
		MS (MOVIE(HQ))					MS (MOVIE(LQ))				
		VIVID	STANDARD MILD OFF	STANDARD MILD ON	PRO MILD OFF	PRO MILD ON	VIVID	STANDARD MILD OFF	STANDARD MILD ON	PRO MILD OFF	PRO MILD ON
0	SHOF	31	31	10	31	31	31	10	31	10	
1	SHF0	15	15	15	15	15	15	15	15	15	
2	SHPC	0	0	0	0	0	0	0	0	0	
3	PROV	8	8	8	8	8	8	8	8	8	
4	HFBT	0	0	0	0	0	0	0	0	0	
5	ULTI	0	0	0	0	0	0	0	0	0	
11	UCTI	0	0	0	0	0	0	0	0	0	
16	MIDE	95	84	84	91	90	99	98	98	96	96
17	APCD	2	2	2	2	2	2	2	2	2	2
18	NRLV	5	5	6	5	5	5	5	6	0	0

No.	Name	Multi Window									
		Twin/Freeze					Index				
		VIVID	STANDARD MILD OFF	STANDARD MILD ON	PRO MILD OFF	PRO MILD ON	VIVID	STANDARD MILD OFF	STANDARD MILD ON	PRO MILD OFF	PRO MILD ON
0	SHOF	31	31	20	31	20	31	31	20	31	20
1	SHF0	14	14	14	14	14	14	14	14	14	14
2	SHPC	0	0	0	0	0	0	0	0	0	0
3	PROV	8	8	8	8	8	8	8	8	8	8
4	HFBT	0	0	0	0	0	0	0	0	0	0
5	ULTI	0	0	0	0	0	0	0	0	0	0
11	UCTI	0	0	0	0	0	0	0	0	0	0
16	MIDE	0	0	0	0	0	0	0	0	0	0
17	APCD	2	2	2	2	2	2	2	2	2	2
18	NRLV	0	0	0	0	0	0	0	0	0	0

No.	Name	Multi Window				
		Favorites				
		VIVID	STANDARD MILD OFF	STANDARD MILD ON	PRO MILD OFF	PRO MILD ON
0	SHOF	31	31	20	31	20
1	SHF0	14	14	14	14	14
2	SHPC	0	0	0	0	0
3	PROV	8	8	8	8	8
4	HFBT	0	0	0	0	0
5	ULTI	0	0	0	0	0
11	UCTI	0	0	0	0	0
16	MIDE	0	0	0	0	0
17	APCD	2	2	2	2	2
18	NRLV	0	0	0	0	0

Standards *2

No.	Name	ULTI=0	ULTI=1	ULTI=2	ULTI=3	ULTI=4	ULTI=5	ULTI=6	ULTI=7
6	LTSL	0	0	1	3	1	2	3	1
7	LTLV	0	1	3	3	1	1	1	2
8	LTDL	0	12	12	15	14	14	14	14
9	LTMD	0	0	0	1	1	1	1	0
10	LTCR	0	0	0	0	0	0	0	0

No.	Name	ULTI=8	ULTI=9	ULTI=10	ULTI=11	ULTI=12	ULTI=13	ULTI=14	ULTI=15
6	LTSL	2	2	2	2	2	1	1	2
7	LTLV	2	3	1	2	3	1	3	3
8	LTDL	14	14	14	14	14	14	14	14
9	LTMD	0	0	1	1	1	0	0	0
10	LTCR	0	0	0	0	0	0	0	0

No.	Name	UCTI=0	UCTI=1	UCTI=2	UCTI=3	UCTI=4	UCTI=5	UCTI=6	UCTI=7
12	CTLV	0	1	2	3	4	5	6	7
13	CTDL	0	6	6	6	6	6	6	6
14	CTMD	0	0	0	0	0	0	0	0
15	CTCR	0	0	0	0	0	0	0	0

No.	Name	UCTI=8	UCTI=9	UCTI=10	UCTI=11	UCTI=12	UCTI=13	UCTI=14	UCTI=15
12	CTLV	8	9	10	11	12	13	14	15
13	CTDL	6	6	6	6	6	6	6	6
14	CTMD	0	0	0	0	0	0	0	0
15	CTCR	0	0	0	0	0	0	0	0

DCP-USER

Functionality		Data	Remarks
No.	Name		
0	UPIC	*1	
1	UBRT	*1	
2	UCOL	*1	
3	UHUE	*1	
4	USHP	*1	
5	UTMP	*1	
6	UDCL	*1	
7	UNRT	*1	
8	UBNR	*1	
9	UDRC	*1	
10	UBLT	*1	
11	UPOF	*2	
12	UBOF	*2	
13	UCOF	*2	
14	UHOF	*2	
15	AXIS	*2	
16	RYB	*3	
17	RYS	*3	
18	GYB	*3	
19	GYR	*3	
20	UGAM	*2	
21	RGAM	*4	
22	GGAM	*4	
23	BGAM	*4	
24	UDCT	*2	
25	DCTR	*5	
26	DCT1	*5	
27	DCT2	*5	
28	UAPD	*2	
29	APDL	*6	
30	APDK	*6	
31	APDD	*6	
32	APDA	*6	
33	APDH	*6	
34	LSCL	*2	
35	UDCI	*2	
36	DCIE	*7	
37	DAUT	*7	
38	DGAI	*7	
39	DLPF	*7	
40	DINF	*7	
41	DPIC	255	
42	DBRT	202	
43	LPSW	0	

Standards *1

No.	Name	WE 42", 50"				WE 60"			
		Vivid	Standard	Pro	Reserved	Vivid	Standard	Pro	Reserved
0	UPIC	63	50	46	48	63	50	46	48
1	UBRT	25	35	31	31	25	35	31	31
2	UCOL	37	34	31	31	37	34	31	31
3	UHUE	31	31	31	31	31	31	31	31
4	USHP	37	35	31	31	42	40	36	31
5	UTMP	2	1	1	3	2	1	1	3
6	UDCL	0	0	0	0	0	0	0	0
7	UNRT	1	2	0	0	1	2	0	0
8	UBNR	0	0	0	0	0	0	0	0
9	UDRC	2	3	1	0	2	3	1	0
10	UBLT	0	0	0	0	0	0	0	0

Standards *2

No.	Name	UV				Video			
		Vivid	Standard	Pro	Reserved	Vivid	Standard	Pro	Reserved
11	UPOF	31	31	31	31	31	31	31	31
12	UBOF	55	37	29	47	55	37	29	47
13	UCOF	32	32	31	34	31	32	31	34
14	UHOF	31	31	31	31	31	31	31	31
15	AXIS	0	0	0	2	0	0	0	2
20	UGAM	6	3	0	5	6	3	0	5
24	UDCT	8	8	0	6	8	8	0	6
28	UAPD	8	4	0	6	8	4	0	6
34	LSCL	60	60	60	60	60	60	60	60
35	UDCI	4	2	0	3	4	2	0	3

No.	Name	ATSC (480i)				ATSC (480p)			
		Vivid	Standard	Pro	Reserved	Vivid	Standard	Pro	Reserved
11	UPOF	31	31	31	31	31	31	31	31
12	UBOF	55	37	29	41	55	37	29	41
13	UCOF	31	32	31	34	31	32	31	34
14	UHOF	31	31	31	31	31	31	31	31
15	AXIS	0	0	0	2	0	0	0	2
20	UGAM	6	3	0	5	6	3	0	5
24	UDCT	8	8	0	8	8	8	0	8
28	UAPD	8	4	0	6	8	4	0	6
34	LSCL	60	60	60	60	60	60	60	60
35	UDCI	4	2	0	3	4	2	0	3

No.	Name	ATSC (1080i)				ATSC (720p)			
		Vivid	Standard	Pro	Reserved	Vivid	Standard	Pro	Reserved
11	UPOF	31	31	31	31	31	31	31	31
12	UBOF	31	31	35	47	31	31	35	47
13	UCOF	31	31	31	31	31	31	31	31
14	UHOF	31	31	31	31	31	31	31	31
15	AXIS	2	2	2	2	2	2	2	2
20	UGAM	10	8	0	7	10	8	0	7
24	UDCT	8	8	0	8	8	8	0	8
28	UAPD	6	3	0	5	6	3	0	5
34	LSCL	60	60	60	60	60	60	60	60
35	UDCI	0	0	0	0	0	0	0	0

No.	Name	DTT/ATSC (LOWER)			
		Vivid	Standard	Pro	Reserved
11	UPOF	31	31	31	31
12	UBOF	31	31	31	31
13	UCOF	31	31	31	31
14	UHOF	31	31	31	31
15	AXIS	2	2	2	2
20	UGAM	8	7	0	7
24	UDCT	8	8	0	8
28	UAPD	10	5	0	5
34	LSCL	60	60	60	60
35	UDCI	0	0	0	0

No.	Name	i.LINK (480i : Except DV)				i.LINK (480p)			
		Vivid	Standard	Pro	Reserved	Vivid	Standard	Pro	Reserved
11	UPOF	31	31	31	31	31	31	31	31
12	UBOF	55	37	29	41	55	37	29	41
13	UCOF	31	32	31	34	31	32	31	34
14	UHOF	31	31	31	31	31	31	31	31
15	AXIS	0	0	0	2	0	0	0	2
20	UGAM	6	3	0	5	6	3	0	5
24	UDCT	8	8	0	8	8	8	0	8
28	UAPD	8	4	0	6	8	4	0	6
34	LSCL	60	60	60	60	60	60	60	60
35	UDCI	4	2	0	3	4	2	0	3

No.	Name	i.LINK (1080i)				i.LINK (720p)			
		Vivid	Standard	Pro	Reserved	Vivid	Standard	Pro	Reserved
11	UPOF	31	31	31	31	31	31	31	31
12	UBOF	31	31	35	47	31	31	35	47
13	UCOF	31	31	31	31	31	31	31	31
14	UHOF	31	31	31	31	31	31	31	31
15	AXIS	2	2	2	2	2	2	2	2
20	UGAM	10	8	0	7	10	8	0	7
24	UDCT	8	8	0	8	8	8	0	8
28	UAPD	6	3	0	5	6	3	0	5
34	LSCL	60	60	60	60	60	60	60	60
35	UDCI	0	0	0	0	0	0	0	0

No.	Name	BS/CS-d/i.LINK (LOWER)				i.LINK (DV)			
		Vivid	Standard	Pro	Reserved	Vivid	Standard	Pro	Reserved
11	UPOF	31	31	31	31	31	31	31	31
12	UBOF	31	47	35	47	55	37	29	41
13	UCOF	31	31	31	31	31	32	31	34
14	UHOF	31	31	31	31	31	31	31	31
15	AXIS	2	2	2	2	0	0	0	2
20	UGAM	8	7	0	7	6	3	0	5
24	UDCT	8	8	0	8	8	8	0	8
28	UAPD	10	5	0	5	8	4	0	6
34	LSCL	60	60	60	60	60	60	60	60
35	UDCI	0	0	0	0	4	2	0	3

No.	Name	IND. DATA (480i)				IND. DATA (ex 480i)			
		Vivid	Standard	Pro	Reserved	Vivid	Standard	Pro	Reserved
11	UPOF	31	31	31	31	31	31	31	31
12	UBOF	31	31	31	31	31	31	31	31
13	UCOF	31	31	31	31	31	31	31	31
14	UHOF	31	31	31	31	31	31	31	31
15	AXIS	2	2	2	2	2	2	2	2
20	UGAM	8	7	0	7	8	7	0	7
24	UDCT	8	8	0	8	8	8	0	8
28	UAPD	10	5	0	5	10	5	0	5
34	LSCL	60	60	60	60	60	60	60	60
35	UDCI	0	0	0	0	0	0	0	0

No.	Name	ADD DATA (480i)				ADD DATA (ex 480i)			
		Vivid	Standard	Pro	Reserved	Vivid	Standard	Pro	Reserved
11	UPOF	31	31	31	31	31	31	31	31
12	UBOF	31	31	31	31	31	31	31	31
13	UCOF	31	31	31	31	31	31	31	31
14	UHOF	31	31	31	31	31	31	31	31
15	AXIS	2	2	2	2	2	2	2	2
20	UGAM	8	7	0	7	8	7	0	7
24	UDCT	8	8	0	8	8	8	0	8
28	UAPD	10	5	0	5	10	5	0	5
34	LSCL	60	60	60	60	60	60	60	60
35	UDCI	0	0	0	0	0	0	0	0

No.	Name	Component (480i)				Component (480p)			
		Vivid	Standard	Pro	Reserved	Vivid	Standard	Pro	Reserved
11	UPOF	31	31	31	31	31	31	31	31
12	UBOF	55	37	29	41	55	37	29	41
13	UCOF	31	32	31	34	31	32	31	34
14	UHOF	31	31	31	31	31	31	31	31
15	AXIS	0	0	0	2	0	0	0	2
20	UGAM	6	3	0	5	6	3	0	5
24	UDCT	8	8	0	8	8	8	0	8
28	UAPD	8	4	0	6	8	4	0	6
34	LSCL	60	60	60	60	60	60	60	60
35	UDCI	4	2	0	3	4	2	0	3

No.	Name	Component (1080i)				Component (720p)			
		Vivid	Standard	Pro	Reserved	Vivid	Standard	Pro	Reserved
11	UPOF	31	31	31	31	31	31	31	31
12	UBOF	31	31	35	47	31	31	35	47
13	UCOF	31	31	31	31	31	31	31	31
14	UHOF	31	31	31	31	31	31	31	31
15	AXIS	2	2	2	2	2	2	2	2
20	UGAM	10	8	0	7	10	8	0	7
24	UDCT	8	8	0	8	8	8	0	8
28	UAPD	6	3	0	5	6	3	0	5
34	LSCL	60	60	60	60	60	60	60	60
35	UDCI	0	0	0	0	0	0	0	0

No.	Name	DVI (480i)				DVI (480p)			
		Vivid	Standard	Pro	Reserved	Vivid	Standard	Pro	Reserved
11	UPOF	31	31	31	31	31	31	31	31
12	UBOF	55	37	29	41	55	37	29	41
13	UCOF	31	32	31	34	31	32	31	34
14	UHOF	31	31	31	31	31	31	31	31
15	AXIS	0	0	0	2	0	0	0	2
20	UGAM	6	3	0	5	6	3	0	5
24	UDCT	8	8	0	8	8	8	0	8
28	UAPD	8	4	0	6	8	4	0	6
34	LSCL	60	60	60	60	60	60	60	60
35	UDCI	4	2	0	3	4	2	0	3

No.	Name	DVI (1080i)				DVI (720p)			
		Vivid	Standard	Pro	Reserved	Vivid	Standard	Pro	Reserved
11	UPOF	31	31	31	31	31	31	31	31
12	UBOF	31	31	35	47	31	31	35	47
13	UCOF	31	31	31	31	31	31	31	31
14	UHOF	31	31	31	31	31	31	31	31
15	AXIS	2	2	2	2	2	2	2	2
20	UGAM	10	8	0	7	10	8	0	7
24	UDCT	8	8	0	8	8	8	0	8
28	UAPD	6	3	0	5	6	3	0	5
34	LSCL	60	60	60	60	60	60	60	60
35	UDCI	0	0	0	0	0	0	0	0

No.	Name	DVI (VGA etc)			
		Vivid	Standard	Pro	Reserved
11	UPOF	31	31	31	31
12	UBOF	55	37	29	41
13	UCOF	31	32	31	34
14	UHOF	31	31	31	31
15	AXIS	0	0	0	2
20	UGAM	6	3	0	5
24	UDCT	8	8	0	8
28	UAPD	8	4	0	6
34	LSCL	60	60	60	60
35	UDCI	4	2	0	3

No.	Name	MS (STILL)				MS (MOVIE(CONT-PANEL))			
		Vivid	Standard	Pro	Reserved	Vivid	Standard	Pro	Reserved
11	UPOF	31	31	31	31	31	31	31	31
12	UBOF	31	31	35	47	31	31	35	47
13	UCOF	31	31	31	31	31	31	31	31
14	UHOF	31	31	31	31	31	31	31	31
15	AXIS	2	2	2	2	2	2	2	2
20	UGAM	10	8	0	7	10	8	0	7
24	UDCT	8	8	0	8	8	8	0	8
28	UAPD	6	3	0	5	6	3	0	5
34	LSCL	60	60	60	60	60	60	60	60
35	UDCI	0	0	0	0	0	0	0	0

No.	Name	MS (MOVIE(HQ))				MS (MOVIE(LQ))			
		Vivid	Standard	Pro	Reserved	Vivid	Standard	Pro	Reserved
11	UPOF	31	31	31	31	31	31	31	31
12	UBOF	31	31	35	47	31	31	35	47
13	UCOF	31	31	31	31	31	31	31	31
14	UHOF	31	31	31	31	31	31	31	31
15	AXIS	2	2	2	2	2	2	2	2
20	UGAM	8	7	0	7	10	8	0	7
24	UDCT	8	8	0	8	8	8	0	8
28	UAPD	10	5	0	5	6	3	0	5
34	LSCL	60	60	60	60	60	60	60	60
35	UDCI	0	0	0	0	0	0	0	0

No.	Name	Multi Window							
		Twin/Freeze				Index			
		Vivid	Standard	Pro	Reserved	Vivid	Standard	Pro	Reserved
11	UPOF	31	31	31	31	31	31	31	31
12	UBOF	31	31	35	47	31	31	35	47
13	UCOF	31	31	31	31	31	31	31	31
14	UHOF	31	31	31	31	31	31	31	31
15	AXIS	2	2	2	2	2	2	2	2
20	UGAM	6	3	0	3	6	3	0	3
24	UDCT	0	0	0	0	0	0	0	0
28	UAPD	0	0	0	0	0	0	0	0
34	LSCL	60	60	60	60	60	60	60	60
35	UDCI	0	0	0	0	0	0	0	0

No.	Name	Multi Window			
		Favorites			
		Vivid	Standard	Pro	Reserved
11	UPOF	31	31	31	31
12	UBOF	31	31	35	47
13	UCOF	31	31	31	31
14	UHOF	31	31	31	31
15	AXIS	2	2	2	2
20	UGAM	6	3	0	3
24	UDCT	0	0	0	0
28	UAPD	0	0	0	0
34	LSCL	60	60	60	60
35	UDCI	0	0	0	0

Standards *3

No.	Name	AXIS=0	AXIS=1	AXIS=2	AXIS=3
16	RYB	24	68	35	70
17	RYR	91	103	130	160
18	GYB	91	69	91	91
19	GYR	127	122	127	127

Standards *4

No.	Name	UGAM=0	UGAM=1	UGAM=2	UGAM=3	UGAM=4	UGAM=5	UGAM=6	UGAM=7
21	RGAM	0	1	2	3	4	5	6	7
22	GGAM	0	1	2	3	4	5	6	7
23	BGAM	0	1	2	3	4	5	6	7

No.	Name	UGAM=8	UGAM=9	UGAM=10	UGAM=11	UGAM=12	UGAM=13	UGAM=14	UGAM=15
21	RGAM	8	9	10	11	12	13	14	15
22	GGAM	8	9	10	11	12	13	14	15
23	BGAM	8	9	10	11	12	13	14	15

Standards *5

No.	Name	UDCT=0	UDCT=1	UDCT=2	UDCT=3	UDCT=4	UDCT=5	UDCT=6	UDCT=7
25	DCTR	0	1	2	3	4	5	6	7
26	DCT1	0	0	0	0	0	0	0	0
27	DCT2	2	2	2	2	2	2	2	2

No.	Name	UDCT=8	UDCT=9	UDCT=10	UDCT=11	UDCT=12	UDCT=13	UDCT=14	UDCT=15
25	DCTR	8	9	10	11	12	13	14	15
26	DCT1	0	0	0	0	0	0	0	0
27	DCT2	2	2	2	2	2	2	2	2

Standards *6

No.	Name	UAPD=0	UAPD=1	UAPD=2	UAPD=3	UAPD=4	UAPD=5	UAPD=6	UAPD=7
29	APDL	0	1	2	3	4	5	6	7
30	APDK	0	16	16	16	16	16	16	16
31	APDD	0	8	8	8	8	8	8	8
32	APDA	0	15	15	15	15	15	15	15
33	APDH	0	0	0	0	0	0	0	0

No.	Name	UAPD=8	UAPD=9	UAPD=10	UAPD=11	UAPD=12	UAPD=13	UAPD=14	UAPD=15
29	APDL	8	9	10	11	12	13	14	15
30	APDK	16	16	16	16	16	16	16	16
31	APDD	8	8	8	8	8	8	8	8
32	APDA	15	15	15	15	15	15	15	15
33	APDH	0	0	0	0	0	0	0	0

Standards *7

No.	Name	UDCI=0	UDCI=1	UDCI=2	UDCI=3	UDCI=4	UDCI=5	UDCI=6	UDCI=7
36	DCIE	0	1	1	1	1	1	1	1
37	DAUT	0	1	1	1	1	1	1	1
38	DGAI	0	4	8	12	16	20	24	28
39	DLPF	0	2	2	2	2	2	2	2
40	DINF	0	38	38	38	38	38	38	38

No.	Name	UDCI=8	UDCI=9	UDCI=10	UDCI=11	UDCI=12	UDCI=13	UDCI=14	UDCI=15
36	DCIE	1	1	1	1	1	1	1	1
37	DAUT	1	1	1	1	1	1	1	1
38	DGAI	32	36	40	44	48	52	56	60
39	DLPF	2	2	2	2	2	2	2	2
40	DINF	38	38	38	38	38	38	38	38

DCP-AVP

Functionality		Data	Remarks
No.	Name		
0	AGAM	*1	
1	ADCI	*2	
2	AAPD	*2	
3	ADCT	*2	
4	AAXI	*3	
5	UNRL	*4	
6	BNRL	*5	

Standards *1

No.	Name	Gamma Correction		
		Low	Middle	High
0	AGAM	5	7	9

Standards *2

No.	Name	Dark Correction		
		Low	Middle	High
1	ADCI	2	4	6
2	AAPD	4	8	12
3	ADCT	4	6	8

Standards *3

No.	Name	Color Correction
		On
4	AAXI	3

Standards *4

No.	Name	User NR Level			
		Off : UNRT = 0	Low : UNRT = 1	Middle : UNRT = 2	High : UNRT = 3
5	UNRL	4	5	6	7

Standards *5

No.	Name	User BNR Level			
		Off : UBNR = 0	Low : UBNR = 1	Middle : UBNR = 2	High : UBNR = 3
6	BNRL	0	1	2	3

USR-NR

Functionality		Data	Remarks
No.	Name		
1	NRLV	*1	
2	RNRP	*1	

Standards *1

No.	Name	UNRL = 0	UNRL = 1	UNRL = 2	UNRL = 3	UNRL = 4	UNRL = 5	UNRL = 6	UNRL = 7
1	NRLV	0	1	2	3	4	5	6	7
2	RNRP	0	0	0	0	0	0	0	0

CXA2171

Functionality		Data	Remarks
No.	Name		
0	MTRX	*1	
1	GAIN	*2	
2	CBGN	*2	
3	VTC	1	
4	HWID	1	
5	HSEP	*2	
6	FRGB	0	
7	HMSK	0	
8	DMST	*2	
9	CLGT	*2	

Standards *1

No.	Name	VIDEO5				VIDEO6			
		480i	480p	1080i	720p	480i	480p	1080i	720p
0	MTRX	0	0	1	1	0	0	1	1

No.	Name	ATSC					DVI
		480i	480p	1080i	720p	MS	
0	MTRX	0	0	1	1	1	0

Standards *2

No.	Name	VIDEO5				VIDEO6			
		480i	480p	1080i	720p	480i	480p	1080i	720p
1	GAIN	0	0	0	0	0	0	0	0
2	CBGN	7	7	7	7	7	7	7	7
5	HSEP	1	1	0	0	1	1	0	0
8	DMST	0	0	0	0	0	0	0	0
9	CLGT	0	0	1	1	0	0	1	1

No.	Name	ATSC					DVI			
		480i	480p	1080i	720p	MS	480i	480p	1080i	720p
1	GAIN	0	0	0	0	0	0	0	0	0
2	CBGN	7	7	7	7	7	7	7	7	7
5	HSEP	1	1	0	0	0	1	1	0	0
8	DMST	0	0	0	0	0	0	0	0	0
9	CLGT	0	0	1	1	1	0	0	1	1

AP

Functionality		Data	Remarks
No.	Name		
0	SVOL	*1	
1	STRE	*1	
2	SBAS	*1	
3	BBE	*1	
4	BBEL	*1	
5	BBEH	*1	
6	MOD1	*2	
7	MOD2	*2	
8	MOD3	*2	
9	AGCL	*2	

Standards *2

No.	Name	42/50inch	60inch
6	MOD1	0	0
7	MOD2	0	0
8	MOD3	0	1
9	AGCL	0	0

Standards *1

No.	Name	Virtual Dolby			TruSurround			Simulated			Others		
		UV	ATSC	Others	UV	ATSC	Others	UV	ATSC	Others	UV	ATSC	Others
0	SVOL	6	6	6	3	7	3	4	7	4	4	7	4
1	STRE	7	7	10		7	11	12	7	13	12	7	13
2	SBAS	7	7	3	10	7	10	10	7	9	10	7	9
3	BBE	1	1	1	1	1	1	1	1	1	1	1	1
4	BBEL	4	4	7	7	4	10	5	4	8	5	4	8
5	BBEH	2	2	4	10	2	10	12	2	13	10	2	13

AK4524

Functionality		Data	Remarks
No.	Name		
0	ATTL	64	
1	ATTR	64	

DLBY

Functionality		Data	Remarks
No.	Name		
0	DBMD	0	
1	SCH	0	
2	ADSW	0	
3	CECH	0	
4	DELY	7	
5	SSEL	0	

SNNR

Functionality		Data	Remarks
No.	Name		
0	SNNR	0	
1	SNFX	0	
2	YNLV	*1	
3	HIST	*1	
4	PSCH	*1	
5	PFUP	*1	
6	PSHP	*1	
7	PYNR	*1	
8	PCNR	*1	
9	PVGA	*1	
10	PRNR	*1	
11	DSHP	*1	
12	DSF0	*1	
13	DLTI	*1	
14	DCTI	*1	
15	DHFB	*1	
16	MINR	*1	
17	VRAO	*1	
18	VRBO	*1	

Standards #1

No.	Name	SNNR0	SNNR1	SNNR2	SNNR3
2	YNLV	-	30	60	80
3	HIST	-	4	4	4
4	PSCH	0	0	1	1
5	PFUP	0	0	1	2
6	PSHP	0	0	0	1
7	PYNR	0	0	0	1
8	PCNR	0	0	0	1
9	PVGA	0	0	0	0
10	PRNR	1	1	1	1
11	DSHP	0	1	2	3
12	DSF0	0	0	1	1
13	DLTI	0	0	1	1
14	DCTI	0	3	7	15
15	DHFB	0	3	7	15
16	MINR	0	1	2	3
17	VRAO	0	3	7	15
18	VRBO	0	0	1	3

SNSS

Functionality		Data	Remarks
No.	Name		
0	SNSS	0	
1	SSFX	0	
2	YNLV	*1	
3	HIST	*1	
4	PSYF	*1	
5	PAFG	*1	
6	PLOG	*1	
7	PHSL	*1	
8	PVSL	*1	

Standards #1

No.	Name	SNSS0	SNSS1	SNSS2
2	YNLV	-	20	255
3	HIST	-	7	7
4	PSYF	0	0	0
5	PAFG	0	1	3
6	PLOG	0	0	3
7	PHSL	0	0	0
8	PVSL	0	0	0

DRCVR

Functionality		Data	Remarks
No.	Name		
0	23PD	*1	
1	MFVR	0	
2	RESO	*2	
3	NOCT	*2	
4	FMAT	0	
5	FMTH	*1	
6	FSEL	*1	
7	CDLY	*1	
8	LMIT	0	
9	LMLV	*3	
10	LMSL	1	
11	VDLY	1	
12	VDPR	3	
13	WPLL	2	
14	CRCT	0	
15	CHG1	2	
16	CHG2	4	
17	CHG3	6	
18	STP1	1	
19	STP2	2	
20	STP3	3	
21	STP4	4	
22	RSOF	*4	
23	NCOF	*4	

Standards *1

No.	Name	UV	Video1	Video2	Video3	Video4	Video5 (Component1)	Video6 (Component2)	ATSC
0	23PD	1	1	1	1	1	1	1	1
5	FMTH	1	1	1	1	1	1	1	1
6	FSEL	1	1	1	1	1	1	1	1
7	CDLY	2	2	2	2	2	2	2	2

No.	Name	Video7 (DVI)	AV-MULTI (YCbCr)	i.LINK (Except DV)	i.LINK (DV)
0	23PD	1	1	1	1
5	FMTH	1	1	1	1
6	FSEL	1	0	1	1
7	CDLY	2	1	2	2

Standards *2

No.	Name	Vivid						
		UV	ATSC	Video	Component	DVI	i.LINK (Except DV)	i.LINK (DV)
2	RESO	59	72	35	72	72	72	72
3	NOCT	218	128	203	128	128	128	128

No.	Name	Standard (Mild Off)						
		UV	ATSC	Video	Component	DVI	i.LINK (Except DV)	i.LINK (DV)
2	RESO	0	72	0	72	72	72	72
3	NOCT	155	128	141	128	128	128	128

No.	Name	Standard (Mild On)						
		UV	ATSC	Video	Component	DVI	i.LINK (Except DV)	i.LINK (DV)
2	RESO	190	190	95	190	190	190	190
3	NOCT	155	128	141	128	128	128	128

No.	Name	Pro (Mild Off)						
		UV	ATSC	Video	Component	DVI	i.LINK (Except DV)	i.LINK (DV)
2	RESO	63	128	89	128	128	128	128
3	NOCT	218	128	201	128	128	128	128

No.	Name	Pro (Mild On)						
		UV	ATSC	Video	Component	DVI	i.LINK (Except DV)	i.LINK (DV)
2	RESO	190	190	190	190	190	190	190
3	NOCT	218	190	201	190	190	190	190

Standards *3

No.	Name	UV				Except UV			
		Vivid	Standard	Pro	Reserved	Vivid	Home	Pro	Reserved
9	LMLV	2	2	2	2	2	2	2	2

Standards *4

No.	Name	DRC Palette		
		Custom1	Custom2	Custom3
22	RSOF	24	49	24
23	NCOF	0	0	24

CCD

Functionality		Data	Remarks
No.	Name		
0	HPRM	58	
1	HPRS	58	
2	YSYM	0	
3	CCDI	3	
4	CRIP	4	
5	PHLD	0	
6	CHMK	52	
7	LANG	2	
8	DATA	0	
9	VCHP	0	
10	CLMP	0	
11	SYSV	3	
12	ID1	1	
13	ID1M	3	
14	FPOL	0	
15	BWHT	0	
16	MESH	0	
17	BNBB	1	
18	BNBG	0	
19	BNBR	0	
20	CMP1	2	
21	CMP2	5	
22	CMP3	3	
23	CWHT	3	
24	VSDW	1	
25	BFRQ	0	
26	BPOS	0	
27	BFRM	1	
28	BTIM	0	

ID

Functionality		Data	Remarks
No.	Name		
0	ID0	89	
1	ID1	247	
2	ID2	239	
3	ID3	107	
4	ID4	0	
5	ID5	99	
6	ID6	54	
7	ID7	23	
8	ID8	34	

OP

Functionality		Data	Remarks
No.	Name		
0	DLY1	4	
1	DLY2	0	
2	DLY3	0	
3	DLY4	4	
4	DLY5	0	
5	DLY6	4	
6	ADLY	15	
7	OSDV	30	
8	OSDH	6	
9	HDPT	1	
10	MSBG	0	
11	RAMW	0	
12	SNON	1	
13	SNO2	0	
14	SSON	1	
15	HLCK	0	
16	XUES	1	
17	AFSO	*1	
18	LIND	*2	
19	MSPR	0	
20	CR68	2	
21	INCH	0	
22	ILLU	1	
23	OSVL	0	
24	OBIT	1	
25	OSMV	70	
26	OSFV	30	

Standards *1

No.	Name	UV	VIDEO1	VIDEO2	VIDEO3	VIDEO4 480i	VIDEO5 480i	DVI 480i
17	AFSO	1	1	1	1	1	1	1

Standards *2

No.	Name	Vivid						
		UV	VIDEO1	VIDEO2	VIDEO3	VIDEO4 480i	VIDEO5 480i	DVI 480i
18	LIND	0	0	0	0	0	0	0

No.	Name	Standard						
		UV	VIDEO1	VIDEO2	VIDEO3	VIDEO4 480i	VIDEO5 480i	DVI 480i
18	LIND	0	0	0	0	0	0	0

No.	Name	Pro						
		UV	VIDEO1	VIDEO2	VIDEO3	VIDEO4 480i	VIDEO5 480i	DVI 480i
18	LIND	0	0	0	0	0	0	0

No.	Name	Mild						
		UV	VIDEO1	VIDEO2	VIDEO3	VIDEO4 480i	VIDEO5 480i	DVI 480i
18	LIND	0	0	0	0	0	0	0

MIDI

Functionality		Data	Remarks
No.	Name		
0	DHPH	*1	
1	DVPH	*1	
2	DHAR	*1	
3	DVAR	*1	
4	DHPW	*1	
5	DVPW	*1	
6	DYCD	*2	
7	DYSD	*3	
8	DYST	*3	
9	MDHP	*4	
10	MDVP	*5	
11	MDHS	*4	
12	MDHO	*4	
13	MDVS	*5	
14	MDVO	*5	
15	MLDT	*6	
16	MLRA	*6	
17	DBCY	*7	
18	DYSS	*8	
19	MDLO	5	
20	DDGO	1	
21	DANO	0	
22	MPIC	3	
23	MPFB	24	
24	MRIN	1	
25	DCSL	1	
26	DRPD	5	
27	NOFR	0	

Standards *1

No.	Name	Panel-0	Panel-1	Panel-2	Panel-3	Panel-4(ex)
0	DHPH	255	255	103	255	255
1	DVPH	255	255	13	255	255
2	DHAR	255	255	177	255	255
3	DVAR	255	255	199	255	255
4	DHPW	255	255	50	255	255
5	DVPW	255	255	3	255	255

Standards *2

No.	Name	Single			
		Analog 480i	Analog other	Digital 480i	Digital other
6	DYCD	0	0	0	0

No.	Name	Twin	Memo	Favorite	Index
6	DYCD	0	0	0	0

Standards *3

No.	Name	Single			
		YSDLY = 0	YSDLY = 1	YSDLY = 2	YSDLY = 3
7	DYSD	8	7	4	4
8	DYST	9	10	6	8

No.	Name	Single			
		YSDLY = 4	YSDLY = 5	YSDLY = 6	YSDLY = 7
7	DYSD	2	0	0	0
8	DYST	5	3	0	0

No.	Name	Single			
		YSDLY = 8	YSDLY = 9	YSDLY = 10	YSDLY = 11
7	DYSD	0	0	0	0
8	DYST	0	0	0	0

No.	Name	Single			
		YSDLY = 12	YSDLY = 13	YSDLY = 14	YSDLY = 15
7	DYSD	0	0	0	0
8	DYST	0	0	0	0

No.	Name	Other			
		YSDLY = 0	YSDLY = 1	YSDLY = 2	YSDLY = 3
7	DYSD	7	6	4	3
8	DYST	8	7	5	4

No.	Name	Other			
		YSDLY = 4	YSDLY = 5	YSDLY = 6	YSDLY = 7
7	DYSD	2	1	0	0
8	DYST	4	3	0	0

No.	Name	Other			
		YSDLY = 8	YSDLY = 9	YSDLY = 10	YSDLY = 11
7	DYSD	0	0	0	0
8	DYST	0	0	0	0

No.	Name	Other			
		YSDLY = 12	YSDLY = 13	YSDLY = 14	YSDLY = 15
7	DYSD	0	0	0	0
8	DYST	0	0	0	0

Standards *4

No.	Name	Panel-0					
		SidePanel	Window SidePanel	Twin(Center)	Favorite	Index	other
9	MDHP	255	255	255	255	255	255
11	MDHS	255	255	255	255	255	255
12	MDHO	255	255	255	255	255	255

No.	Name	Panel-1					
		SidePanel	Window SidePanel	Twin(Center)	Favorite	Index	other
9	MDHP	255	255	255	255	255	255
11	MDHS	255	255	255	255	255	255
12	MDHO	255	255	255	255	255	255

No.	Name	Panel-2 (42")					
		SidePanel	Window SidePanel	Twin(Center)	Favorite	Index	other
9	MDHP	107	255	17	21	255	12
11	MDHS	33	255	33	33	255	224
12	MDHO	46	255	30	46	255	46

No.	Name	42" Default Panel-2					
		SidePanel	Window SidePanel	Twin(Center)	Favorite	Index	other
9	MDHP	107		17	21		12
11	MDHS						
12	MDHO						

No.	Name	Panel-2 (50")					
		SidePanel	Window SidePanel	Twin(Center)	Favorite	Index	other
9	MDHP	104	255	13	18	255	8
11	MDHS	38	255	37	38	255	231
12	MDHO	46	255	30	46	255	46

No.	Name	50" Default Panel-2					
		SidePanel	Window SidePanel	Twin(Center)	Favorite	Index	other
9	MDHP	104		13	18		8
11	MDHS						
12	MDHO						

No.	Name	Panel-2 (60")					
		SidePanel	Window SidePanel	Twin(Center)	Favorite	Index	other
9	MDHP	105	255	13	16	255	7
11	MDHS	39	255	37	39	255	233
12	MDHO	46	255	30	46	255	46

No.	Name	60" Default Panel-2					
		SidePanel	Window SidePanel	Twin(Center)	Favorite	Index	other
9	MDHP	105		13	16		7
11	MDHS						
12	MDHO						

No.	Name	Panel-3					
		SidePanel	Window SidePanel	Twin(Center)	Favorite	Index	other
9	MDHP	255	255	255	255	255	255
11	MDHS	255	255	255	255	255	255
12	MDHO	255	255	255	255	255	255

No.	Name	Panel-4					
		SidePanel	Window SidePanel	Twin(Center)	Favorite	Index	other
9	MDHP	255	255	255	255	255	255
11	MDHS	255	255	255	255	255	255
12	MDHO	255	255	255	255	255	255

Standards *5

No.	Name	Panel-0			
		Single	Twin(Center)	Favorite	Index
10	MDVP	255	255	255	255
13	MDVS	255	255	255	255
14	MDVO	255	255	255	255

No.	Name	Panel-1			
		Single	Twin(Center)	Favorite	Index
10	MDVP	255	255	255	255
13	MDVS	255	255	255	255
14	MDVO	255	255	255	255

No.	Name	Panel-2 (42")			
		Single	Twin(Center)	Favorite	Index
10	MDVP	20	152	14	255
13	MDVS	116	92	128	255
14	MDVO	64	40	64	255

No.	Name	Panel-2 (42") Default			
		Single	Twin(Center)	Favorite	Index
10	MDVP	14	152	14	
13	MDVS				
14	MDVO				

No.	Name	Panel-2 (50")			
		Single	Twin(Center)	Favorite	Index
10	MDVP	14	152	14	255
13	MDVS	128	92	128	255
14	MDVO	64	40	64	255

No.	Name	Panel-2 (50") Default			
		Single	Twin(Center)	Favorite	Index
10	MDVP	14	152	14	
13	MDVS				
14	MDVO				

No.	Name	Panel-2 (60")			
		Single	Twin(Center)	Favorite	Index
10	MDVP	20	156	20	255
13	MDVS	116	84	116	255
14	MDVO	64	40	64	255

No.	Name	Panel-2 (60") Default			
		Single	Twin(Center)	Favorite	Index
10	MDVP	20	156	20	
13	MDVS				
14	MDVO				

No.	Name	Panel-3			
		Single	Twin(Center)	Favorite	Index
10	MDVP	255	255	255	255
13	MDVS	255	255	255	255
14	MDVO	255	255	255	255

No.	Name	Panel-4 (CRT use)				
		Single 480i-input	Twin(Center)	Favorite	Index	Single 540p-input
10	MDVP	255	255	255	255	255
13	MDVS	255	255	255	255	255
14	MDVO	255	255	255	255	255

Standards *6

No.	Name	Panel-0				Panel-1			
		TWIN/MEMO	Favorite	Index	MS	TWIN/MEMO	Favorite	Index	MS
15	MLDT	255	255	255	255	255	255	255	255
16	MLRA	255	255	255	255	255	255	255	255

No.	Name	Panel-2				Panel-3			
		TWIN/MEMO	Favorite	Index	MS	TWIN/MEMO	Favorite	Index	MS
15	MLDT	7	10	255	32	255	255	255	255
16	MLRA	72	98	255	54	255	255	255	255

No.	Name	Panel-2 (Default)				Panel-3			
		TWIN/MEMO	Favorite	Index	MS	TWIN/MEMO	Favorite	Index	MS
15	MLDT				32				
16	MLRA				0				

No.	Name	Panel-4			
		TWIN/MEMO	Favorite	Index	MS
15	MLDT	255	255	255	255
16	MLRA	255	255	255	255

Standards *7

No.	Name	Single		Free	MS
		SidePanel	other		
17	DBCY	4	4	16	4

No.	Name	other	AutoProgram	All Black	All White
17	DBCY	4	16	1	62

Standards *8

No.	Name	Favorite	Single	Twin/Memo	MS	MS-Movie
18	DYSS	3	3	3	3	3

MID2

Functionality		Data	Remarks
No.	Name		
0	RHPL	*1	
1	RHSL	*1	
2	RVPL	*1	
3	RVSL	*1	
4	RHPR	*1	
5	RHSR	*1	
6	RVPR	*1	
7	RVSR	*1	
8	PABY	1	
9	PACB	0	
10	PAON	0	
11	PANP	0	
12	PACU	0	

Standards *1

No.	Name	Single Component 480i				
		SidePanel	Full	Widezoom	Zoom	Caption
		0	RHPL	159	145	145
1	RHSL	163	170	170	170	255
2	RVPL	49	49	69	105	255
3	RVSL	115	115	105	87	255

No.	Name	Single Composite 480i(CV)				
		SidePanel	Full	Widezoom	Zoom	Caption
		0	RHPL	156	141	141
1	RHSL	163	170	170	170	255
2	RVPL	49	49	69	105	255
3	RVSL	115	115	105	87	255

No.	Name	Single DVI 480i				
		SidePanel	Full	Widezoom	Zoom	Caption
		0	RHPL	160	146	146
1	RHSL	163	170	170	170	255
2	RVPL	48	48	68	104	255
3	RVSL	115	115	105	87	255

No.	Name	Single AVM 480i(YCbCr)				
		SidePanel	Full	Widezoom	Zoom	Caption
		0	RHPL	255	255	255
1	RHSL	255	255	255	255	255
2	RVPL	255	255	255	255	255
3	RVSL	255	255	255	255	255

No.	Name	Single Digital 480i				
		SidePanel	Full	Widezoom	Zoom	Caption
		0	RHPL	255	255	255
1	RHSL	255	255	255	255	255
2	RVPL	255	255	255	255	255
3	RVSL	255	255	255	255	255

No.	Name	Single ATSC 480i				
		SidePanel	Full	Widezoom	Zoom	Caption
		0	RHPL	157	143	143
1	RHSL	164	171	171	171	255
2	RVPL	48	48	70	106	255
3	RVSL	115	115	104	86	255

No.	Name	TWIN/MEMO						
		Component 480i	Composite 480i	DVI 480i	AVM 480i (YCbCr)	Digital 480i	Digital 480i (Side Panel)	ATSC 480i
0	RHPL	143	136	143	143	255	255	141
1	RHSL	167	168	167	167	255	255	168
2	RVPL	56	56	59	59	255	255	55
3	RVSL	111	111	111	111	255	255	111
4	RHPR	159	153	159	159	255	255	156
5	RHSR	167	168	167	167	255	255	168
6	RVPR	56	56	59	59	255	255	55
7	RVSR	111	111	111	111	255	255	111

No.	Name	INDEX	
		Composite 480i	Digital 480i
0	RHPL	255	255
1	RHSL	255	255
2	RVPL	255	255
3	RVSL	255	255

No.	Name	Favorite						
		Component 480i	Composite 480i	DVI 480i	AVM 480i (YCbCr)	Digital 480i	Digital 480i (Side Panel)	ATSC 480i
0	RHPL	152	147	152	255	255	255	152
1	RHSL	165	165	165	255	255	255	165
2	RVPL	48	48	50	255	255	255	49
3	RVSL	115	115	115	255	255	255	115
4	RHPR	255	255	255	255	255	255	
5	RHSR	255	255	255	255	255	255	
6	RVPR	255	255	255	255	255	255	
7	RVSR	255	255	255	255	255	255	

MID3

Functionality		Data	Remarks
No.	Name		
0	VHPL	*1	
1	VHSL	*1	
2	VVPL	*1	
3	VVSL	*1	
4	VHPR	*1	
5	VHSR	*1	
6	VVPR	*1	
7	VVSR	*1	
8	VCPO	*2	
9	VCWD	*2	
10	VYCD	*2	
11	VSTP	*2	
12	VSTT	*2	
13	VFRV	*2	

Standards *1

No.	Name	TWIN/MEMO				
		Digital 1080i other	Digital 1080i SP	Digital 1035i other	Digital 1035i SP	Component 720p
0	VHPL	255				255
1	VHSL	255				255
2	VVPL	255				255
3	VVSL	255				255
4	VHPR	255	255	255	255	255
5	VHSR	255	255	255	255	255
6	VVPR	255	255	255	255	255
7	VVSR	255	255	255	255	255

No.	Name	TWIN/MEMO			
		AVM 720p(RGB)	AVM 720p(YCbCr)	Digital 720p other	Digital 720p SP
0	VHPL	255	255	255	
1	VHSL	255	255	255	
2	VVPL	255	255	255	
3	VVSL	255	255	255	
4	VHPR	255	255	255	255
5	VHSR	255	255	255	255
6	VVPR	255	255	255	255
7	VVSR	255	255	255	255

No.	Name	TWIN/MEMO			
		Component 480p	AVM 480p(RGB)	AVM 480p(YCbCr)	Digital 480p other
0	VHPL	255	255	255	255
1	VHSL	255	255	255	255
2	VVPL	255	255	255	255
3	VVSL	255	255	255	255
4	VHPR	255	255	255	255
5	VHSR	255	255	255	255
6	VVPR	255	255	255	255
7	VVSR	255	255	255	255

No.	Name	TWIN/MEMO			
		Digital 480p SP	Component 1035i	AVM 1035i(RGB)	AVM 1035i(YCbCr)
0	VHPL	255	255	255	255
1	VHSL	255	255	255	255
2	VVPL	255	255	255	255
3	VVSL	255	255	255	255
4	VHPR	255	255	255	255
5	VHSR	255	255	255	255
6	VVPR	255	255	255	255
7	VVSR	255	255	255	255

No.	Name	TWIN/MEMO				
		Component 480i	Composite 480i	AVM 480i(RGB)	AVM 480i(YCbCr)	DTT 480i other
0	VHPL	255	255	255	255	255
1	VHSL	255	255	255	255	255
2	VVPL	255	255	255	255	255
3	VVSL	255	255	255	255	255
4	VHPR	255	76	255	255	255
5	VHSR	255	84	255	255	255
6	VVPR	255	26	255	255	255
7	VVSR	255	56	255	255	255

No.	Name	TWIN/MEMO			Favorite Composite 480i
		DTT 480i SP	Digital 240p	Digital 120p	
0	VHPL		255	255	
1	VHSL		255	255	
2	VVPL		255	255	
3	VVSL		255	255	
4	VHPR				77
5	VHSR				83
6	VVPR				14
7	VVSR				59

Standards *2

No.	Name	Component 1080i	AVM 1080i(RGB)	AVM 1080i(YCbCr)	Digital 1080i
8	VCPO	0	0	0	0
9	VCWD	0	0	0	0
10	VYCD	0	0	0	0
11	VSTP	0	0	0	0
12	VSTT	0	0	0	0
13	VFRV	0	0	0	0

No.	Name	Component 480p	AVM 480p(RGB)	AVM 480p(YCbCr)	Digital 480p
8	VCPO	0	0	0	0
9	VCWD	0	0	0	0
10	VYCD	0	0	0	0
11	VSTP	0	0	0	0
12	VSTT	0	0	0	0
13	VFRV	0	0	0	0

No.	Name	Component 480i	Composite 480i	AVM 480i(RGB)	AVM 480i(YCbCr)	Analog(DTT)480i
8	VCPO	0	0	0	0	0
9	VCWD	0	0	0	0	0
10	VYCD	0	0	0	0	0
11	VSTP	0	0	0	0	0
12	VSTT	0	0	0	0	0
13	VFRV	0	0	0	0	0

No.	Name	Component 720p	AVM 720p(RGB)	AVM 720p(YCbCr)	Digital 720p
8	VCPO	0	0	0	0
9	VCWD	0	0	0	0
10	VYCD	0	0	0	0
11	VSTP	0	0	0	0
12	VSTT	0	0	0	0
13	VFRV	0	0	0	0

No.	Name	Component 1035i	AVM 1035i(RGB)	AVM 1035i(YCbCr)	Digital 1035i
8	VCPO	0	0	0	0
9	VCWD	0	0	0	0
10	VYCD	0	0	0	0
11	VSTP	0	0	0	0
12	VSTT	0	0	0	0
13	VFRV	0	0	0	0

No.	Name	Digital 480i	Digital 240p	Digital 120p	VGA
8	VCPO	0	0	0	0
9	VCWD	0	0	0	0
10	VYCD	0	0	0	0
11	VSTP	0	0	0	0
12	VSTT	0	0	0	0
13	VFRV	0	0	0	0

MID4

Functionality		Data	Remarks
No.	Name		
0	DHPL	*1	
1	DHSL	*1	
2	DVPL	*1	
3	DVSL	*1	
4	DHPR	*1	
5	DHSR	*1	
6	DVPR	*1	
7	DVSR	*1	
8	DCPO	*2	
9	DCWD	*2	
10	DYCD	*2	
11	DSTP	*2	
12	DSTT	*2	
13	DFRV	*2	

Standards *1

No.	Name	Single									
		Component 1080i					DVI 1080i(RGB)				
		SidePanel	Full	WideZoom	Zoom	Caption	SidePanel	Full	WideZoom	Zoom	Caption
0	DHPL	255	138	255	255	255	255	137	255	255	255
1	DHSL	255	230	255	255	255	255	230	255	255	255
2	DVPL	255	36	255	255	255	255	36	255	255	255
3	DVSL	255	129	255	255	255	255	129	255	255	255

No.	Name	Single									
		AVM 1080i(YCbCr)					Digital 1080i				
		SidePanel	Full	WideZoom	Zoom	Caption	Full (1920)	Full (1440)	Full (1280)	SidePanel	
0	DHPL	255	255	255	255	255	255	255	255	255	
1	DHSL	255	255	255	255	255	255	255	255	255	
2	DVPL	255	255	255	255	255	255	255	255	255	
3	DVSL	255	255	255	255	255	255	255	255	255	

No.	Name	Single									
		Component 720p					DVI 720p(RGB)				
		SidePanel	Full	WideZoom	Zoom	Caption	SidePanel	Full	WideZoom	Zoom	Caption
0	DHPL	255	165	255	255	255	255	164	255	255	255
1	DHSL	255	153	255	255	255	255	153	255	255	255
2	DVPL	255	43	255	255	255	255	47	255	255	255
3	DVSL	255	171	255	255	255	255	171	255	255	255

No.	Name	Single							
		AVM 720p(YCbCr)					Digital 720p		
		SidePanel	Full	WideZoom	Zoom	Caption	Full	SidePanel	
0	DHPL	255	255	255	255	255	255	255	
1	DHSL	255	255	255	255	255	255	255	
2	DVPL	255	255	255	255	255	255	255	
3	DVSL	255	255	255	255	255	255	255	

No.	Name	Single									
		Component 480p					VGA				
		SidePanel	Full	Widezoom	Zoom	Caption	SidePanel	Full	Widezoom	Zoom	Caption
0	DHPL	211	191	191	191	255	196	177	177	177	255
1	DHSL	217	227	227	227	255	220	229	229	229	255
2	DVPL	45	45	69	105	255	35	35	59	95	255
3	DVSL	116	116	104	86	255	120	120	108	90	255

No.	Name	Single									
		Digital 480p (720)					Digital 480p (640)				
		SidePanel	Full	Widezoom	Zoom	Caption	SidePanel	Full	Widezoom	Zoom	Caption
0	DHPL	255	255	255	255	255	255	255	255	255	
1	DHSL	255	255	255	255	255	255	255	255	255	
2	DVPL	255	255	255	255	255	255	255	255	255	
3	DVSL	255	255	255	255	255	255	255	255	255	

No.	Name	Single		
		Digital 240p		Digital 120p
		SidePanel	Full (other)	Full (other)
0	DHPL	255	255	255
1	DHSL	255	255	255
2	DVPL	255	255	255
3	DVSL	255	255	255

No.	Name	Single									
		DVI 480p					AVM 480p(YCbCr)				
		SidePanel	Full	Widezoom	Zoom	Caption	SidePanel	Full	Widezoom	Zoom	Caption
0	DHPL	208	188	188	188	255	255	255	255	255	255
1	DHSL	217	227	227	227	255	255	255	255	255	255
2	DVPL	43	43	67	103	255	255	255	255	255	255
3	DVSL	116	116	104	86	255	255	255	255	255	255

No.	Name	Single									
		Component 480i					Composite 480i(CV)				
		SidePanel	Full (other)	Widezoom	Zoom	Caption	SidePanel	Full (other)	Widezoom	Zoom	Caption
0	DHPL	255	255	255	255	255	255	255	255	255	255
1	DHSL	255	255	255	255	255	255	255	255	255	255
2	DVPL	255	255	255	255	255	255	255	255	255	255
3	DVSL	255	255	255	255	255	255	255	255	255	255

No.	Name	Single									
		AVM 480i(RGB)					AVM 480i(YCbCr)				
		SidePanel	Full (other)	Widezoom	Zoom	Caption	SidePanel	Full (other)	Widezoom	Zoom	Caption
0	DHPL	255	255	255	255	255	255	255	255	255	255
1	DHSL	255	255	255	255	255	255	255	255	255	255
2	DVPL	255	255	255	255	255	255	255	255	255	255
3	DVSL	255	255	255	255	255	255	255	255	255	255

No.	Name	Single				
		Digital 480i				
		SidePanel	Full (other)	Widezoom	Zoom	Caption
0	DHPL	255	255	255	255	255
1	DHSL	255	255	255	255	255
2	DVPL	255	255	255	255	255
3	DVSL	255	255	255	255	255

No.	Name	Single									
		ATSC 1080i					ATSC 720p				
		SidePanel	Full (other)	Widezoom	Zoom	Caption	SidePanel	Full (other)	Widezoom	Zoom	Caption
0	DHPL	255	138	255	255	255	255	165	255	255	255
1	DHSL	255	230	255	255	255	255	153	255	255	255
2	DVPL	255	36	255	255	255	255	43	255	255	255
3	DVSL	255	129	255	255	255	255	171	255	255	255

No.	Name	Single									
		ATSC 480p					ATSC 480i(not DRC)				
		SidePanel	Full (other)	Widezoom	Zoom	Caption	SidePanel	Full (other)	Widezoom	Zoom	Caption
0	DHPL	202	184	184	184	255	255	255	255	255	255
1	DHSL	220	229	229	229	255	255	255	255	255	255
2	DVPL	48	48	70	104	255	255	255	255	255	255
3	DVSL	114	114	103	86	255	255	255	255	255	255

No.	Name	Single				
		ATSC MS(1080i)				
		SidePanel	Full (other)	Widezoom	Zoom	Caption
0	DHPL		138			
1	DHSL		230			
2	DVPL		36			
3	DVSL		129			

No.	Name	Single				
		Component 1035i	AVM 1035i(RGB)	AVM 1035i(YCbCr)	Digital 1035i	SidePanel
		Full	Full	Full	Full	SidePanel
0	DHPL	255	255	255	255	
1	DHSL	255	255	255	255	
2	DVPL	255	255	255	255	
3	DVSL	255	255	255	255	

No.	Name	TWIN/MEMO									
		Component 1080i	DVI 1080i(RGB)	AVM 1080i(YCbCr)	Digital 1080i(Full)	Digital 1080i(SidePanel)	Component 720p	DVI 720p	AVM 720p(YCbCr)	Digital 720p(Full)	Digital 720p(SidePanel)
0	DHPL	135	135	255	255	255	162	162	255	255	255
1	DHSL	226	226	255	255	255	151	151	255	255	255
2	DVPL	43	43	255	255	255	55	61	255	255	255
3	DVSL	124	124	255	255	255	165	165	255	255	255
4	DHPR	157	157	255	255	255	177	177	255	255	255
5	DHSR	226	226	255	255	255	151	151	255	255	255
6	DVPR	43	43	255	255	255	55	61	255	255	255
7	DVSR	124	124	255	255	255	165	165	255	255	255

No.	Name	TWIN/MEMO									
		Component 480p	AVM 480p(RGB)	AVM 480p(YCbCr)	Digital 480p(Full)	Digital 480p(SidePanel)	Component 1035i	AVM 1035i(RGB)	AVM 1035i(YCbCr)	Digital 1035i	Digital 1035i(SidePanel)
0	DHPL	186	184	255	255	255	255	255	255	255	255
1	DHSL	224	224	255	255	255	255	255	255	255	255
2	DVPL	53	53	255	255	255	255	255	255	255	255
3	DVSL	112	112	255	255	255	255	255	255	255	255
4	DHPR	208	206	255	255	255	255	255	255	255	255
5	DHSR	224	224	255	255	255	255	255	255	255	255
6	DVPR	53	53	255	255	255	255	255	255	255	255
7	DVSR	112	112	255	255	255	255	255	255	255	255

No.	Name	TWIN/MEMO						
		Component 480i	Composite 480i	AVM 480i(RGB)	AVM 480i(YCbCr)	Digital 480i(Full)	Digital 480i(SidePanel)	VGA
0	DHPL	255	255	255	255	255	255	169
1	DHSL	255	255	255	255	255	255	227
2	DVPL	255	255	255	255	255	255	51
3	DVSL	255	255	255	255	255	255	112
4	DHPR	255	255	255	255	255	255	193
5	DHSR	255	255	255	255	255	255	227
6	DVPR	255	255	255	255	255	255	51
7	DVSR	255	255	255	255	255	255	112

No.	Name	TWIN/MEMO			
		ATSC 1080i	ATSC 720p	ATSC 480p	ATSC 480i
0	DHPL	135	162	179	255
1	DHSL	226	151	226	255
2	DVPL	43	55	57	255
3	DVSL	124	165	110	255
4	DHPR	157	177	202	255
5	DHSR	226	151	226	255
6	DVPR	43	55	57	255
7	DVSR	124	165	110	255

No.	Name	INDEX					
		Component 480i	Digital 1080i	Digital 1035i	Digital 720p	Digital 480p	Digital 480i
0	DHPL	255	255	255	255	255	255
1	DHSL	255	255	255	255	255	255
2	DVPL	255	255	255	255	255	255
3	DVSL	255	255	255	255	255	255
4	DHPR						
5	DHSR						
6	DVPR						
7	DVSR						

No.	Name	Favorite									
		Component 1080i	DVI 1080i	AVM 1080i YCbCr	Digital 1080i(other)	Digital 1080i(SidePanel)	Component 1035i	AVM 1035i RGB	AVM 1035i YCbCr	Digital 1035i(other)	Digital 1035i(SidePanel)
0	DHPL	150	150	255	255	255	255	255	255	255	255
1	DHSL	222	222	255	255	255	255	255	255	255	255
2	DVPL	43	43	255	255	255	255	255	255	255	255
3	DVSL	124	124	255	255	255	255	255	255	255	255

No.	Name	Favorite									
		Component 720p	DVI 720p RGB	AVM 720p YCbCr	Digital 720p(other)	Digital 720p(SidePanel)	Component 480p	DVI 480p	AVM 480p(YCbCr)	Digital 480p(Full)	Digital 480p(SidePanel)
0	DHPL	173	172	255	255	255	200	198	255	255	255
1	DHSL	148	148	255	255	255	220	220	255	255	255
2	DVPL	55	61	255	255	255	45	46	255	255	255
3	DVSL	165	165	255	255	255	116	116	255	255	255

No.	Name	Favorite						
		Component 480i	Composite 480i	AVM 480i(RGB)	AVM 480i(YCbCr)	Digital 480i(Full)	Digital 480i(SidePanel)	VGA
0	DHPL	255	255	255	255	255	255	189
1	DHSL	255	255	255	255	255	255	222
2	DVPL	255	255	255	255	255	255	33
3	DVSL	255	255	255	255	255	255	121

No.	Name	Favorite			
		ATSC 1080i	ATSC 720p	ATSC 480p	ATSC 480i
0	DHPL	150	173	194	255
1	DHSL	222	148	222	255
2	DVPL	43	55	55	255
3	DVSL	124	165	111	255

Standards *2

No.	Name	Component 1080i	AVM 1080i(RGB)	AVM 1080i(YCbCr)	Digital 1080i	Component 720p	AVM 720p(RGB)	AVM 720p(YCbCr)	Digital 720p
8	DCPO	0	0	0	0	0	0	0	0
9	DCWD	0	0	0	0	0	0	0	0
10	DYCD	0	0	0	0	0	0	0	0
11	DSTP	0	0	0	0	0	0	0	0
12	DSTT	0	0	0	0	0	0	0	0
13	DFRV	0	0	0	0	0	0	0	0

No.	Name	Component 480p	AVM 480p(RGB)	AVM 480p(YCbCr)	Digital 480p	Component 1035i	AVM 1035i(RGB)	AVM 1035i(YCbCr)	Digital 1035i
8	DCPO	0	0	0	0	0	0	0	0
9	DCWD	0	0	0	0	0	0	0	0
10	DYCD	0	0	0	0	0	0	0	0
11	DSTP	0	0	0	0	0	0	0	0
12	DSTT	0	0	0	0	0	0	0	0
13	DFRV	0	0	0	0	0	0	0	0

No.	Name	Component 480i	Composite 480i	AVM 480i(RGB)	AVM 480i(YCbCr)	Digital 480i	Digital 240p	Digital 120p	VGA
8	DCPO	0	0	0	0	0	0	0	0
9	DCWD	0	0	0	0	0	0	0	0
10	DYCD	0	0	0	0	0	0	0	0
11	DSTP	0	0	0	0	0	0	0	0
12	DSTT	0	0	0	0	0	0	0	0
13	DFRV	0	0	0	0	0	0	0	0

No.	Name	ATSC 1080i	ATSC 720p	ATSC 480p	ATSC 480i	ATSC MS
8	DCPO	0	0	0	0	0
9	DCWD	0	0	0	0	0
10	DYCD	0	0	0	0	0
11	DSTP	0	0	0	0	0
12	DSTT	0	0	0	0	0
13	DFRV	0	0	0	0	0

MID5

Functionality		Data	Remarks
No.	Name		
0	POP		
1	MHFM	*1	
2	MVFM	*1	
3	MVLS	*1	
4	MHLC	*1	
5	MVLC	*1	
6	MVEC	*1	
7	MXCO	*1	
8	MXHI	*1	
9	MXMO	*1	
10	MXCR	*1	
11	MXCL	*1	
12	MXEN	*1	
13	MXLT	*1	
14	MYCO	*1	
15	MYHI	*1	
16	MYMO	*1	
17	MYCR	*1	
18	MYCL	*1	
19	MYEN	*1	
20	MYLT	*1	
21	MKMO	*1	
22	MKCO	*1	
23	MKCL	*1	
24	MKEN	*1	
25	MKLT	*1	
26	MKTH	*1	
27	MKDW	*1	

Standards *1

No.	Name	Reserved				UV			
		Pro	Pro+	Standard	Vivid	Pro	Pro+	Standard	Vivid
		POP=0	POP=1	POP=2	POP=3	POP=4	POP=5	POP=6	POP=7
1	MHFM	3	3	3	3	3	3	3	3
2	MVFM	3	3	3	3	3	3	3	3
3	MVLS	0	0	0	0	1	1	0	0
4	MHLC	2	2	2	2	3	3	3	3
5	MVLC	0	0	0	0	3	3	2	2
6	MVEC	0	0	0	0	1	1	1	1
7	MXCO	0	0	0	0	1	1	1	1
8	MXHI	0	0	0	0	0	0	0	0
9	MXMO	1	1	1	1	0	0	0	0
10	MXCR	2	2	2	2	2	2	2	2
11	MXCL	3	3	3	3	3	3	3	3
12	MXEN	0	3	5	7	2	4	6	7
13	MXLT	2	2	2	2	3	3	3	3
14	MYCO	0	0	0	0	5	5	5	5
15	MYHI	0	0	0	0	0	0	0	0
16	MYMO	1	1	1	1	0	0	0	0
17	MYCR	2	2	2	2	2	2	2	2
18	MYCL	3	3	3	3	3	3	3	3
19	MYEN	0	3	5	7	0	0	0	0
20	MYLT	2	2	2	2	3	3	3	3
21	MKMO	1	1	1	1	0	0	0	0
22	MKCO	2	2	2	2	1	1	1	1
23	MKCL	3	3	3	3	0	0	0	0
24	MKEN	0	2	3	4	0	0	0	0
25	MKLT	2	2	2	2	3	3	3	3
26	MKTH	0	0	0	0	0	0	0	0
27	MKDW	0	0	0	0	0	0	0	0

No.	Name	Video				iLINK(DV)			
		Pro	Pro+	Standard	Vivid	Pro	Pro+	Standard	Vivid
		POP=8	POP=9	POP=10	POP=11	POP=12	POP=13	POP=14	POP=15
1	MHFM	3	3	3	3	3	3	3	3
2	MVFM	3	3	3	3	3	3	3	3
3	MVLS	1	1	0	0	1	1	0	0
4	MHLC	3	3	3	3	3	3	3	3
5	MVLC	3	3	2	2	1	1	0	0
6	MVEC	1	1	1	1	1	1	1	1
7	MXCO	1	1	1	1	3	3	3	3
8	MXHI	0	0	0	0	0	0	0	0
9	MXMO	0	0	0	0	1	1	1	1
10	MXCR	2	2	2	2	1	1	1	1
11	MXCL	3	3	3	3	2	2	2	2
12	MXEN	2	4	6	7	2	4	6	7
13	MXLT	3	3	3	3	2	2	2	2
14	MYCO	5	5	5	5	0	0	0	0
15	MYHI	0	0	0	0	0	0	0	0
16	MYMO	0	0	0	0	1	1	1	1
17	MYCR	2	2	2	2	1	1	1	1
18	MYCL	3	3	3	3	2	2	2	2
19	MYEN	0	1	2	3	2	4	6	7
20	MYLT	3	3	3	3	2	2	2	2
21	MKMO	0	0	0	0	0	0	1	1
22	MKCO	1	1	1	1	0	0	1	1
23	MKCL	0	0	0	0	0	0	3	3
24	MKEN	0	0	0	0	0	0	7	7
25	MKLT	3	3	3	3	0	0	3	3
26	MKTH	0	0	0	0	0	0	0	0
27	MKDW	0	0	0	0	0	0	0	0

No.	Name	ATSC(480i)				ATSC(480p)			
		Pro	Pro+	Standard	Vivid	Pro	Pro+	Standard	Vivid
		POP=16	POP=17	POP=18	POP=19	POP=20	POP=21	POP=22	POP=23
1	MHFM	3	3	3	3	3	3	3	3
2	MVFM	3	3	3	3	3	3	3	3
3	MVLS	1	1	0	0	1	1	0	0
4	MHLC	3	3	3	3	3	3	3	3
5	MVLC	1	1	0	0	2	2	0	0
6	MVEC	1	1	1	1	1	1	1	1
7	MXCO	3	3	3	3	3	3	3	3
8	MXHI	0	0	0	0	0	0	0	0
9	MXMO	1	1	1	1	1	1	1	1
10	MXCR	1	1	1	1	1	1	1	1
11	MXCL	2	2	2	2	2	2	2	2
12	MXEN	2	4	6	7	2	4	6	7
13	MXLT	2	2	2	2	2	2	2	2
14	MYCO	0	0	0	0	0	0	0	0
15	MYHI	0	0	0	0	0	0	0	0
16	MYMO	1	1	1	1	1	1	1	1
17	MYCR	1	1	1	1	1	1	1	1
18	MYCL	2	2	2	2	2	2	2	2
19	MYEN	2	4	6	7	2	4	6	7
20	MYLT	2	2	2	2	2	2	2	2
21	MKMO	0	0	1	1	0	0	1	1
22	MKCO	0	0	1	1	0	0	1	1
23	MKCL	0	0	3	3	0	0	3	3
24	MKEN	0	0	7	7	0	0	7	7
25	MKLT	0	0	3	3	0	0	3	3
26	MKTH	0	0	0	0	0	0	0	0
27	MKDW	0	0	0	0	0	0	0	0

No.	Name	ATSC(1080i)				ATSC(720p)			
		Pro	Pro+	Standard	Vivid	Pro	Pro+	Standard	Vivid
		POP=24	POP=25	POP=26	POP=27	POP=28	POP=29	POP=30	POP=31
1	MHFM	2	2	2	2	2	2	2	2
2	MVFM	2	2	2	2	2	2	2	2
3	MVLS	0	0	0	0	0	0	0	0
4	MHLC	2	2	2	2	2	2	2	2
5	MVLC	0	0	0	0	0	0	0	0
6	MVEC	1	1	1	1	1	1	1	1
7	MXCO	1	1	1	1	1	1	1	1
8	MXHI	0	0	0	0	0	0	0	0
9	MXMO	1	1	1	1	1	1	1	1
10	MXCR	1	1	1	1	1	1	1	1
11	MXCL	2	2	2	2	2	2	2	2
12	MXEN	2	4	6	7	2	4	6	7
13	MXLT	3	3	3	3	3	3	3	3
14	MYCO	0	0	0	0	0	0	0	0
15	MYHI	0	0	0	0	0	0	0	0
16	MYMO	1	1	1	1	1	1	1	1
17	MYCR	1	1	1	1	1	1	1	1
18	MYCL	2	2	2	2	2	2	2	2
19	MYEN	2	2	4	7	2	2	4	7
20	MYLT	3	3	3	3	3	3	3	3
21	MKMO	0	0	1	1	0	0	1	1
22	MKCO	0	0	1	1	0	0	1	1
23	MKCL	0	0	2	2	0	0	2	2
24	MKEN	0	2	4	7	0	2	4	7
25	MKLT	0	0	3	3	0	0	3	3
26	MKTH	0	0	0	0	0	0	0	0
27	MKDW	0	0	0	0	0	0	0	0

No.	Name	iLINK(480i)				i LINK(480p)			
		Pro	Pro+	Standard	Vivid	Pro	Pro+	Standard	Vivid
		POP=32	POP=33	POP=34	POP=35	POP=36	POP=37	POP=38	POP=39
1	MHFM	3	3	3	3	3	3	3	3
2	MVFM	3	3	3	3	3	3	3	3
3	MVLS	1	1	0	0	1	1	0	0
4	MHLC	3	3	3	3	3	3	3	3
5	MVLC	1	1	0	0	2	2	0	0
6	MVEC	1	1	1	1	1	1	1	1
7	MXCO	3	3	3	3	3	3	3	3
8	MXHI	0	0	0	0	0	0	0	0
9	MXMO	1	1	1	1	1	1	1	1
10	MXCR	1	1	1	1	1	1	1	1
11	MXCL	2	2	2	2	2	2	2	2
12	MXEN	2	4	6	7	2	4	6	7
13	MXLT	2	2	2	2	2	2	2	2
14	MYCO	0	0	0	0	0	0	0	0
15	MYHI	0	0	0	0	0	0	0	0
16	MYMO	1	1	1	1	1	1	1	1
17	MYCR	1	1	1	1	1	1	1	1
18	MYCL	2	2	2	2	2	2	2	2
19	MYEN	2	4	6	7	2	4	6	7
20	MYLT	2	2	2	2	2	2	2	2
21	MKMO	0	0	1	1	0	0	1	1
22	MKCO	0	0	1	1	0	0	1	1
23	MKCL	0	0	3	3	0	0	3	3
24	MKEN	0	0	7	7	0	0	7	7
25	MKLT	0	0	3	3	0	0	3	3
26	MKTH	0	0	0	0	0	0	0	0
27	MKDW	0	0	0	0	0	0	0	0

No.	Name	iLINK(1080i)				iLINK(720p)			
		Pro	Pro+	Standard	Vivid	Pro	Pro+	Standard	Vivid
		POP=40	POP=41	POP=42	POP=43	POP=44	POP=45	POP=46	POP=47
1	MHFM	2	2	2	2	2	2	2	2
2	MVFM	2	2	2	2	2	2	2	2
3	MVLS	0	0	0	0	0	0	0	0
4	MHLC	2	2	2	2	2	2	2	2
5	MVLC	0	0	0	0	0	0	0	0
6	MVEC	1	1	1	1	1	1	1	1
7	MXCO	1	1	1	1	1	1	1	1
8	MXHI	0	0	0	0	0	0	0	0
9	MXMO	1	1	1	1	1	1	1	1
10	MXCR	1	1	1	1	1	1	1	1
11	MXCL	2	2	2	2	2	2	2	2
12	MXEN	2	4	6	7	2	4	6	7
13	MXLT	3	3	3	3	3	3	3	3
14	MYCO	0	0	0	0	0	0	0	0
15	MYHI	0	0	0	0	0	0	0	0
16	MYMO	1	1	1	1	1	1	1	1
17	MYCR	1	1	1	1	1	1	1	1
18	MYCL	2	2	2	2	2	2	2	2
19	MYEN	2	2	4	7	2	2	4	7
20	MYLT	3	3	3	3	3	3	3	3
21	MKMO	0	0	1	1	0	0	1	1
22	MKCO	0	0	1	1	0	0	1	1
23	MKCL	0	0	2	2	0	0	2	2
24	MKEN	0	2	4	7	0	2	4	7
25	MKLT	0	0	3	3	0	0	3	3
26	MKTH	0	0	0	0	0	0	0	0
27	MKDW	0	0	0	0	0	0	0	0

No.	Name	Component(480i)				Component(480p)			
		Pro	Pro+	Standard	Vivid	Pro	Pro+	Standard	Vivid
		POP=48	POP=49	POP=50	POP=51	POP=52	POP=53	POP=54	POP=55
1	MHFM	3	3	3	3	3	3	3	3
2	MVFM	3	3	3	3	3	3	3	3
3	MVLS	1	1	0	0	1	1	0	0
4	MHLC	3	3	3	3	3	3	3	3
5	MVLC	1	1	0	0	2	2	0	0
6	MVEC	1	1	1	1	1	1	1	1
7	MXCO	3	3	3	3	3	3	3	3
8	MXHI	0	0	0	0	0	0	0	0
9	MXMO	1	1	1	1	1	1	1	1
10	MXCR	1	1	1	1	1	1	1	1
11	MXCL	2	2	2	2	2	2	2	2
12	MXEN	2	4	6	7	2	4	6	7
13	MXLT	2	2	2	2	2	2	2	2
14	MYCO	0	0	0	0	0	0	0	0
15	MYHI	0	0	0	0	0	0	0	0
16	MYMO	1	1	1	1	1	1	1	1
17	MYCR	1	1	1	1	1	1	1	1
18	MYCL	2	2	2	2	2	2	2	2
19	MYEN	2	4	6	7	2	4	6	7
20	MYLT	2	2	2	2	2	2	2	2
21	MKMO	0	0	1	1	0	0	1	1
22	MKCO	0	0	1	1	0	0	1	1
23	MKCL	0	0	3	3	0	0	3	3
24	MKEN	0	0	7	7	0	0	7	7
25	MKLT	0	0	3	3	0	0	3	3
26	MKTH	0	0	0	0	0	0	0	0
27	MKDW	0	0	0	0	0	0	0	0

No.	Name	Component(1080i)				Component(720p)			
		Pro	Pro+	Standard	Vivid	Pro	Pro+	Standard	Vivid
		POP=56	POP=57	POP=58	POP=59	POP=60	POP=61	POP=62	POP=63
1	MHFM	2	2	2	2	2	2	2	2
2	MVFM	2	2	2	2	2	2	2	2
3	MVLS	0	0	0	0	0	0	0	0
4	MHLC	2	2	2	2	2	2	2	2
5	MVLC	0	0	0	0	0	0	0	0
6	MVEC	1	1	1	1	1	1	1	1
7	MXCO	1	1	1	1	1	1	1	1
8	MXHI	0	0	0	0	0	0	0	0
9	MXMO	1	1	1	1	1	1	1	1
10	MXCR	1	1	1	1	1	1	1	1
11	MXCL	2	2	2	2	2	2	2	2
12	MXEN	2	4	6	7	2	4	6	7
13	MXLT	3	3	3	3	3	3	3	3
14	MYCO	0	0	0	0	0	0	0	0
15	MYHI	0	0	0	0	0	0	0	0
16	MYMO	1	1	1	1	1	1	1	1
17	MYCR	1	1	1	1	1	1	1	1
18	MYCL	2	2	2	2	2	2	2	2
19	MYEN	2	2	4	7	2	2	4	7
20	MYLT	3	3	3	3	3	3	3	3
21	MKMO	0	0	1	1	0	0	1	1
22	MKCO	0	0	1	1	0	0	1	1
23	MKCL	0	0	2	2	0	0	2	2
24	MKEN	0	2	4	7	0	2	4	7
25	MKLT	0	0	3	3	0	0	3	3
26	MKTH	0	0	0	0	0	0	0	0
27	MKDW	0	0	0	0	0	0	0	0

No.	Name	DVI(480i)				DVI(480p)			
		Pro	Pro+	Standard	Vivid	Pro	Pro+	Standard	Vivid
		POP=64	POP=65	POP=66	POP=67	POP=68	POP=69	POP=70	POP=71
1	MHFM	3	3	3	3	3	3	3	3
2	MVFM	3	3	3	3	3	3	3	3
3	MVLS	1	1	0	0	1	1	0	0
4	MHLC	3	3	3	3	3	3	3	3
5	MVLC	1	1	0	0	2	2	0	0
6	MVEC	1	1	1	1	1	1	1	1
7	MXCO	3	3	3	3	3	3	3	3
8	MXHI	0	0	0	0	0	0	0	0
9	MXMO	1	1	1	1	1	1	1	1
10	MXCR	1	1	1	1	1	1	1	1
11	MXCL	2	2	2	2	2	2	2	2
12	MXEN	2	4	6	7	2	4	6	7
13	MXLT	2	2	2	2	2	2	2	2
14	MYCO	0	0	0	0	0	0	0	0
15	MYHI	0	0	0	0	0	0	0	0
16	MYMO	1	1	1	1	1	1	1	1
17	MYCR	1	1	1	1	1	1	1	1
18	MYCL	2	2	2	2	2	2	2	2
19	MYEN	2	4	6	7	2	4	6	7
20	MYLT	2	2	2	2	2	2	2	2
21	MKMO	0	0	1	1	0	0	1	1
22	MKCO	0	0	1	1	0	0	1	1
23	MKCL	0	0	3	3	0	0	3	3
24	MKEN	0	0	7	7	0	0	7	7
25	MKLT	0	0	3	3	0	0	3	3
26	MKTH	0	0	0	0	0	0	0	0
27	MKDW	0	0	0	0	0	0	0	0

No.	Name	DVI(1080i)				DVI(720p)			
		Pro	Pro+	Standard	Vivid	Pro	Pro+	Standard	Vivid
		POP=72	POP=73	POP=74	POP=75	POP=76	POP=77	POP=78	POP=79
1	MHFM	2	2	2	2	2	2	2	2
2	MVFM	2	2	2	2	2	2	2	2
3	MVLS	0	0	0	0	0	0	0	0
4	MHLC	2	2	2	2	2	2	2	2
5	MVLC	0	0	0	0	0	0	0	0
6	MVEC	1	1	1	1	1	1	1	1
7	MXCO	1	1	1	1	1	1	1	1
8	MXHI	0	0	0	0	0	0	0	0
9	MXMO	1	1	1	1	1	1	1	1
10	MXCR	1	1	1	1	1	1	1	1
11	MXCL	2	2	2	2	2	2	2	2
12	MXEN	2	4	6	7	2	4	6	7
13	MXLT	3	3	3	3	3	3	3	3
14	MYCO	0	0	0	0	0	0	0	0
15	MYHI	0	0	0	0	0	0	0	0
16	MYMO	1	1	1	1	1	1	1	1
17	MYCR	1	1	1	1	1	1	1	1
18	MYCL	2	2	2	2	2	2	2	2
19	MYEN	2	2	4	7	2	2	4	7
20	MYLT	3	3	3	3	3	3	3	3
21	MKMO	0	0	1	1	0	0	1	1
22	MKCO	0	0	1	1	0	0	1	1
23	MKCL	0	0	2	2	0	0	2	2
24	MKEN	0	2	4	7	0	2	4	7
25	MKLT	0	0	3	3	0	0	3	3
26	MKTH	0	0	0	0	0	0	0	0
27	MKDW	0	0	0	0	0	0	0	0

No.	Name	DVI(VGA)				Memory Strick(Still)			
		Pro	Pro+	Standard	Vivid	Pro	Pro+	Standard	Vivid
		POP=80	POP=81	POP=82	POP=83	POP=84	POP=85	POP=86	POP=87
1	MHFM	3	3	3	3	2	2	2	2
2	MVFM	3	3	3	3	2	2	2	2
3	MVLS	1	1	0	0	0	0	0	0
4	MHLC	3	3	3	3	2	2	2	2
5	MVLC	2	2	0	0	0	0	0	0
6	MVEC	1	1	1	1	1	1	1	1
7	MXCO	3	3	3	3	0	0	0	0
8	MXHI	0	0	0	0	0	0	0	0
9	MXMO	1	1	1	1	0	0	0	0
10	MXCR	1	1	1	1	0	0	0	0
11	MXCL	2	2	2	2	0	0	0	0
12	MXEN	2	4	6	7	0	0	0	0
13	MXLT	2	2	2	2	0	0	0	0
14	MYCO	0	0	0	0	0	0	0	0
15	MYHI	0	0	0	0	0	0	0	0
16	MYMO	1	1	1	1	0	0	0	0
17	MYCR	1	1	1	1	0	0	0	0
18	MYCL	2	2	2	2	0	0	0	0
19	MYEN	2	4	6	7	0	0	0	0
20	MYLT	2	2	2	2	0	0	0	0
21	MKMO	0	0	1	1	0	0	0	0
22	MKCO	0	0	1	1	0	0	0	0
23	MKCL	0	0	3	3	0	0	0	0
24	MKEN	0	0	7	7	0	0	0	0
25	MKLT	0	0	3	3	0	0	0	0
26	MKTH	0	0	0	0	0	0	0	0
27	MKDW	0	0	0	0	0	0	0	0

No.	Name	Memory Strick(Movie : Control Panel)				Reserved			
		Pro	Pro+	Standard	Vivid	Pro	Pro+	Standard	Vivid
		POP=88	POP=89	POP=90	POP=91	POP=92	POP=93	POP=94	POP=95
1	MHFM	2	2	2	2	0	0	0	0
2	MVFM	2	2	2	2	0	0	0	0
3	MVLS	0	0	0	0	0	0	0	0
4	MHLC	2	2	2	2	0	0	0	0
5	MVLC	0	0	0	0	0	0	0	0
6	MVEC	1	1	1	1	0	0	0	0
7	MXCO	0	0	0	0	0	0	0	0
8	MXHI	0	0	0	0	0	0	0	0
9	MXMO	0	0	0	0	0	0	0	0
10	MXCR	0	0	0	0	0	0	0	0
11	MXCL	0	0	0	0	0	0	0	0
12	MXEN	0	0	0	0	0	0	0	0
13	MXLT	0	0	0	0	0	0	0	0
14	MYCO	0	0	0	0	0	0	0	0
15	MYHI	0	0	0	0	0	0	0	0
16	MYMO	0	0	0	0	0	0	0	0
17	MYCR	0	0	0	0	0	0	0	0
18	MYCL	0	0	0	0	0	0	0	0
19	MYEN	0	0	0	0	0	0	0	0
20	MYLT	0	0	0	0	0	0	0	0
21	MKMO	0	0	0	0	0	0	0	0
22	MKCO	0	0	0	0	0	0	0	0
23	MKCL	0	0	0	0	0	0	0	0
24	MKEN	0	0	0	0	0	0	0	0
25	MKLT	0	0	0	0	0	0	0	0
26	MKTH	0	0	0	0	0	0	0	0
27	MKDW	0	0	0	0	0	0	0	0

No.	Name	Memory Strick(Movie : Low Quality)				Reserved			
		Pro	Pro+	Standard	Vivid	Pro	Pro+	Standard	Vivid
		POP=96	POP=97	POP=98	POP=99	POP=100	POP=101	POP=102	POP=103
1	MHFM	2	2	2	2	0	0	0	0
2	MVFM	2	2	2	2	0	0	0	0
3	MVLS	0	0	0	0	0	0	0	0
4	MHLC	2	2	2	2	0	0	0	0
5	MVLC	0	0	0	0	0	0	0	0
6	MVEC	1	1	1	1	0	0	0	0
7	MXCO	0	0	0	0	0	0	0	0
8	MXHI	0	0	0	0	0	0	0	0
9	MXMO	0	0	0	0	0	0	0	0
10	MXCR	0	0	0	0	0	0	0	0
11	MXCL	0	0	0	0	0	0	0	0
12	MXEN	0	0	0	0	0	0	0	0
13	MXLT	0	0	0	0	0	0	0	0
14	MYCO	0	0	0	0	0	0	0	0
15	MYHI	0	0	0	0	0	0	0	0
16	MYMO	0	0	0	0	0	0	0	0
17	MYCR	0	0	0	0	0	0	0	0
18	MYCL	0	0	0	0	0	0	0	0
19	MYEN	0	0	0	0	0	0	0	0
20	MYLT	0	0	0	0	0	0	0	0
21	MKMO	0	0	0	0	0	0	0	0
22	MKCO	0	0	0	0	0	0	0	0
23	MKCL	0	0	0	0	0	0	0	0
24	MKEN	0	0	0	0	0	0	0	0
25	MKLT	0	0	0	0	0	0	0	0
26	MKTH	0	0	0	0	0	0	0	0
27	MKDW	0	0	0	0	0	0	0	0

No.	Name	Reserved							
		Pro	Pro+	Standard	Vivid	Pro	Pro+	Standard	Vivid
		POP=104	POP=105	POP=106	POP=107	POP=108	POP=109	POP=110	POP=111
1	MHFM	0	0	0	0	0	0	0	0
2	MVFM	0	0	0	0	0	0	0	0
3	MVLS	0	0	0	0	0	0	0	0
4	MHLC	0	0	0	0	0	0	0	0
5	MVLC	0	0	0	0	0	0	0	0
6	MVEC	0	0	0	0	0	0	0	0
7	MXCO	0	0	0	0	0	0	0	0
8	MXHI	0	0	0	0	0	0	0	0
9	MXMO	0	0	0	0	0	0	0	0
10	MXCR	0	0	0	0	0	0	0	0
11	MXCL	0	0	0	0	0	0	0	0
12	MXEN	0	0	0	0	0	0	0	0
13	MXLT	0	0	0	0	0	0	0	0
14	MYCO	0	0	0	0	0	0	0	0
15	MYHI	0	0	0	0	0	0	0	0
16	MYMO	0	0	0	0	0	0	0	0
17	MYCR	0	0	0	0	0	0	0	0
18	MYCL	0	0	0	0	0	0	0	0
19	MYEN	0	0	0	0	0	0	0	0
20	MYLT	0	0	0	0	0	0	0	0
21	MKMO	0	0	0	0	0	0	0	0
22	MKCO	0	0	0	0	0	0	0	0
23	MKCL	0	0	0	0	0	0	0	0
24	MKEN	0	0	0	0	0	0	0	0
25	MKLT	0	0	0	0	0	0	0	0
26	MKTH	0	0	0	0	0	0	0	0
27	MKDW	0	0	0	0	0	0	0	0

No.	Name	Reserved							
		Pro	Pro+	Standard	Vivid	Pro	Pro+	Standard	Vivid
		POP=112	POP=113	POP=114	POP=115	POP=116	POP=117	POP=118	POP=119
1	MHFM	0	0	0	0	0	0	0	0
2	MVFM	0	0	0	0	0	0	0	0
3	MVLS	0	0	0	0	0	0	0	0
4	MHLC	0	0	0	0	0	0	0	0
5	MVLC	0	0	0	0	0	0	0	0
6	MVEC	0	0	0	0	0	0	0	0
7	MXCO	0	0	0	0	0	0	0	0
8	MXHI	0	0	0	0	0	0	0	0
9	MXMO	0	0	0	0	0	0	0	0
10	MXCR	0	0	0	0	0	0	0	0
11	MXCL	0	0	0	0	0	0	0	0
12	MXEN	0	0	0	0	0	0	0	0
13	MXLT	0	0	0	0	0	0	0	0
14	MYCO	0	0	0	0	0	0	0	0
15	MYHI	0	0	0	0	0	0	0	0
16	MYMO	0	0	0	0	0	0	0	0
17	MYCR	0	0	0	0	0	0	0	0
18	MYCL	0	0	0	0	0	0	0	0
19	MYEN	0	0	0	0	0	0	0	0
20	MYLT	0	0	0	0	0	0	0	0
21	MKMO	0	0	0	0	0	0	0	0
22	MKCO	0	0	0	0	0	0	0	0
23	MKCL	0	0	0	0	0	0	0	0
24	MKEN	0	0	0	0	0	0	0	0
25	MKLT	0	0	0	0	0	0	0	0
26	MKTH	0	0	0	0	0	0	0	0
27	MKDW	0	0	0	0	0	0	0	0

No.	Name	Reserved							
		Pro	Pro+	Standard	Vivid	Pro	Pro+	Standard	Vivid
		POP=120	POP=121	POP=122	POP=123	POP=124	POP=125	POP=126	POP=127
1	MHFM	0	0	0	0	0	0	0	0
2	MVFM	0	0	0	0	0	0	0	0
3	MVLS	0	0	0	0	0	0	0	0
4	MHLC	0	0	0	0	0	0	0	0
5	MVLC	0	0	0	0	0	0	0	0
6	MVEC	0	0	0	0	0	0	0	0
7	MXCO	0	0	0	0	0	0	0	0
8	MXHI	0	0	0	0	0	0	0	0
9	MXMO	0	0	0	0	0	0	0	0
10	MXCR	0	0	0	0	0	0	0	0
11	MXCL	0	0	0	0	0	0	0	0
12	MXEN	0	0	0	0	0	0	0	0
13	MXLT	0	0	0	0	0	0	0	0
14	MYCO	0	0	0	0	0	0	0	0
15	MYHI	0	0	0	0	0	0	0	0
16	MYMO	0	0	0	0	0	0	0	0
17	MYCR	0	0	0	0	0	0	0	0
18	MYCL	0	0	0	0	0	0	0	0
19	MYEN	0	0	0	0	0	0	0	0
20	MYLT	0	0	0	0	0	0	0	0
21	MKMO	0	0	0	0	0	0	0	0
22	MKCO	0	0	0	0	0	0	0	0
23	MKCL	0	0	0	0	0	0	0	0
24	MKEN	0	0	0	0	0	0	0	0
25	MKLT	0	0	0	0	0	0	0	0
26	MKTH	0	0	0	0	0	0	0	0
27	MKDW	0	0	0	0	0	0	0	0

MID6

Functionality		Data	Remarks
No.	Name		
1	MBT1	*1	
2	MNHF	*1	
3	MNON	*1	
4	MNOF	*1	
5	MNMO	*1	
6	MNFB	*1	
7	MNGR	*1	
8	MNLR	*1	
9	MNCR	*1	
10	MNCC	*1	
11	MNFL	*1	
12	MNCO	*1	
13	MNMV	*1	

Standards *1

No.	Name	other							
		NRTBL=0	NRTBL=1	NRTBL=2	NRTBL=3	NRTBL=4	NRTBL=5	NRTBL=6	NRTBL=7
1	MBT1	5	5	5	5	5	5	5	5
2	MNHF	0	0	0	0	0	0	0	0
3	MNON	1	1	1	1	1	1	1	1
4	MNOF	1	1	1	1	1	1	1	1
5	MNMO	0	0	0	0	0	0	0	0
6	MNFB	1	2	2	2	0	1	2	2
7	MNGR	1	2	3	3	0	2	3	3
8	MNLR	1	0	1	0	0	1	3	0
9	MNCR	0	0	0	0	0	0	0	0
10	MNCC	0	0	0	0	0	0	0	0
11	MNFL	0	0	0	0	0	0	0	0
12	MNCO	0	0	0	0	0	0	0	0
13	MNMV	0	0	0	0	0	0	0	0

No.	Name	720p							
		NRTBL=0	NRTBL=1	NRTBL=2	NRTBL=3	NRTBL=4	NRTBL=5	NRTBL=6	NRTBL=7
1	MBT1	5	5	5	5	5	5	5	5
2	MNHF	0	0	0	0	0	0	0	0
3	MNON	1	1	1	1	1	1	1	1
4	MNOF	1	1	1	1	1	1	1	1
5	MNMO	0	0	0	0	0	0	0	0
6	MNFB	1	2	2	2	0	1	2	2
7	MNGR	1	2	3	3	0	2	3	3
8	MNLR	1	0	1	0	0	1	3	0
9	MNCR	0	0	0	0	0	0	0	0
10	MNCC	0	0	0	0	0	0	0	0
11	MNFL	0	0	0	0	0	0	0	0
12	MNCO	0	0	0	0	0	0	0	0
13	MNMV	0	0	0	0	0	0	0	0

MID7

Functionality		Data	Remarks
No.	Name		
0	MION	*1	
1	MIWR	*1	
2	MIMO	*1	
3	MSTA	*1	
4	MF22	*1	
5	MFPH	*1	
6	MIBM	*1	
7	MIUP	*1	
8	MSTP	*1	
9	MSOF	*1	
10	MSTY	*1	
11	MSTC	*1	
12	MIFL	*1	
13	MIHC	*1	
14	MISO	*1	
15	MIMX	*1	
16	MILC	*1	
17	MIRA	*1	
18	MIOR	*1	
19	MIFB	*1	
20	MIVC	*1	
21	MFIF	*1	
22	DIPM	*1	
23	MFOC	*1	
24	MCPA	*1	
25	MSTE	*1	
26	MFLM	*1	
27	MCED	*1	
28	MCCO	*1	
29	MFSL	*1	
30	MVAL	*1	
31	MVIG	*1	

Standards *1

No.	Name	Other	VIVID			STANDARD		
			Single 1080i/1035i	Single 480i(not DRC)	Single other	Single 1080i/1035i	Single 480i(not DRC)	Single other
0	MION	1	1	1	1	1	1	1
1	MIWR	1	1	1	1	1	1	1
2	MIMO	0	0	0	0	0	0	0
3	MSTA	0	0	0	0	0	0	0
4	MF22	0	0	0	0	0	0	0
5	MFPH	0	0	0	0	0	0	0
6	MIBM	1	1	1	1	1	1	1
7	MIUP	1	1	1	1	1	1	1
8	MSTP	1	1	1	1	1	1	1
9	MSOF	4	4	4	4	4	4	4
10	MSTY	4	4	4	4	4	4	4
11	MSTC	4	4	4	4	4	4	4
12	MIFL	0	0	0	0	0	0	0
13	MIHC	4	4	4	4	4	4	4
14	MISO	1	1	1	1	1	1	1
15	MIMX	3	3	3	3	3	3	3
16	MILC	2	2	2	2	2	2	2
17	MIRA	3	3	3	3	3	3	3
18	MIOR	1	1	1	1	1	1	1
19	MIFB	2	2	2	2	2	2	2
20	MIVC	3	3	3	3	3	3	3
21	MFIF	1	1	1	1	1	1	1
22	DIPM	0	0	0	0	0	0	0
23	MFOC	3	3	3	3	3	3	3
24	MCPA	10	10	10	10	10	10	10
25	MSTE	1	1	1	1	1	1	1
26	MFLM	0	0	0	0	0	0	0
27	MCED	8	8	8	8	8	8	8
28	MCCO	8	8	8	8	8	8	8
29	MFSL	0	0	0	0	0	0	0
30	MVAL	0	0	0	0	0	0	0
31	MVIG	0	0	0	0	0	0	0

No.	Name	MILD			PRO		
		Single 1080i/1035i	Single 480i(not DRC)	Single other	Single 1080i/1035i	Single 480i(not DRC)	Single other
0	MION	1	1	1	1	1	1
1	MIWR	1	1	1	1	1	1
2	MIMO	0	0	0	0	0	0
3	MSTA	0	0	0	0	0	0
4	MF22	0	0	0	0	0	0
5	MFPH	0	0	0	0	0	0
6	MIBM	1	1	1	1	1	1
7	MIUP	1	1	1	1	1	1
8	MSTP	1	1	1	1	1	1
9	MSOF	4	4	4	4	4	4
10	MSTY	4	4	4	4	4	4
11	MSTC	4	4	4	4	4	4
12	MIFL	0	0	0	0	0	0
13	MIHC	4	4	4	4	4	4
14	MISO	1	1	1	1	1	1
15	MIMX	3	3	3	3	3	3
16	MILC	2	2	2	2	2	2
17	MIRA	3	3	3	3	3	3
18	MIOR	1	1	1	1	1	1
19	MIFB	2	2	2	2	2	2
20	MIVC	3	3	3	3	3	3
21	MFIF	1	1	1	1	1	1
22	DIPM	0	0	0	0	0	0
23	MFOC	3	3	3	3	3	3
24	MCPA	10	10	10	10	10	10
25	MSTE	1	1	1	1	1	1
26	MFLM	0	0	0	0	0	0
27	MCED	8	8	8	8	8	8
28	MCCO	8	8	8	8	8	8
29	MFSL	0	0	0	0	0	0
30	MVAL	0	0	0	0	0	0
31	MVIG	0	0	0	0	0	0

MID8

Functionality		Data	Remarks
No.	Name		
0	SHFM	2	
1	SVFM	2	
2	SHLC	0	
3	SVLC	0	
4	SHMO	0	
5	SHLT	0	
6	SHCR	0	
7	SHCL	0	
8	SHEN	0	
9	SHCO	0	
10	SVMO	0	
11	SVLT	0	
12	SVCR	0	
13	SVCL	0	
14	SVEN	0	

MID9

Functionality		Data	Remarks
No.	Name		
0	SION	1	
1	SISL	2	
2	SIWR	1	
3	SIMV	1	
4	SFIF	1	
5	STLD	1	
6	PAFL	1	
7	SCOU	2	
8	SSTA	1	
9	SSTP	1	
10	IPFL	0	
11	IPFS	0	
12	PATS	0	
13	PASE	2	
14	PAR0	0	
15	PAR1	0	
16	PAT1	41	
17	PAT2	81	
18	PAT3	106	
19	PAT5	120	

D9671-1

Functionality		Data	Remarks
No.	Name		
0	I2CSCAL	49	
1	LUTPERM	1	
2	COPYENAB	1	
3	REFPERM	1	
4	REFLENGT	0	
5	SLAVE	87	
6	INSWAP	5	
7	RINBSWAP	1	
8	GINBSWAP	1	
9	BINBSWAP	1	
10	OUTSWAP	5	
11	ROUTBSWAP	1	
12	GOUTBSWAP	1	
13	BOUTBSWAP	0	
14	OSDTHRU	0	
15	MUTE	0	
16	3DGSW	1	
17	LUTTHRU	0	
18	DOTLINE	9	
19	CSCMODE	0	
20	PWIDTHH	86	
21	PWIDTHL	9	
22	PHEIGHTH	3	
23	PHEIGHTL	19	
24	3DGOFFSET	0	
25	3DGNONL	0	
26	3DGWEGT	2	
27	ROSDGAIN	0	
28	GOSDGAINH	0	
29	GOSDGAINL	0	
30	BOSDGAIN	0	
31	YMOSD	0	
32	IOSD	0	

D9671PIC

Functionality		Data	Remarks
No.	Name		
0	APCMODE	0	
1	APCSW	*1	
2	APCGAIN	*1	
3	APCCORE	*1	
4	APCLIMIT	*1	
5	CONTRAST	0	
6	SCON	18	
7	BRT	0	
8	SBRT	50	
9	RGAIN	127	
10	GGAIN	127	
11	BGAIN	127	
12	RBIAS	127	
13	GBIAS	127	
14	BBIAS	127	
15	BLK-LEFH	*2	
16	BLK-LEFL	*2	
17	BLK-RIH	*2	
18	BLK-RIL	*2	
19	BLK-TOH	0	
20	BLK-TOL	0	
21	BLK-BOH	0	
22	BLK-BOL	0	
23	BLK-LEVEL	0	
24	SCONOF	*3	
25	SBRTOF	*3	
26	RGAINOF	*3	
27	GGAINOF	*3	
28	BGAINOF	*3	
29	RBIASOF	*3	
30	GBIASOF	*3	
31	BBIASOF	*3	

Standards *1

No.	Name	APCMODE=0	APCMODE=1	APCMODE=2	APCMODE=3
1	APCSW	0	1	1	1
2	APCGAIN	64	80	40	45
3	APCCORE	127	63	63	10
4	APCLIMIT	64	30	30	30

No.	Name	APCMODE=4	APCMODE=5	APCMODE=6	APCMODE=7
1	APCSW	0	0	0	0
2	APCGAIN	64	64	64	64
3	APCCORE	127	127	127	127
4	APCLIMIT	64	64	64	64

Standards *2

No.	Name	normal	wide
15	BLK-LEFH	0	0
16	BLK-LEFL	0	0
17	BLK-RIH	0	0
18	BLK-RIL	0	0

Standards *3

No.	Name	Color temp3(Neutral)	Color temp1(Warm)
24	SCONOF	128	128
25	SBRTOF	128	128
26	RGAINOF	135	145
27	GGAINOF	124	124
28	BGAINOF	110	90
29	RBIASOF	128	130
30	GBIASOF	126	126
31	BBIASOF	122	122

D9671TPN

Functionality		Data	Remarks
No.	Name		
0	TPNSW	0	
1	TRNRGB	7	
2	TPNMODE	0	
3	TPNHV	0	
4	TPNINV	0	
5	TPNREP	0	
6	TPNSLANT	0	
7	TPNWIDTH	80	
8	WINPOSHH	32	
9	WINPOSHL	1	
10	WINPOSVH	1	
11	WINPOSVL	18	
12	RHLVLH	63	
13	RHLVLL	15	
14	GHLVLH	15	
15	GHLVLL	63	
16	BHLVLH	3	
17	BHLVLL	255	
18	RLVLH	0	
19	RLVLL	0	
20	GLVLH	0	
21	GLVLL	0	
22	BLVLH	0	
23	BLVLL	0	

D9671TG1

Functionality		Data	Remarks
No.	Name		
0	MSB-STPH	0	
1	STAPOSH	216	
2	STAPOSV	16	
3	TGOFF	0	
4	HSTPOL	0	
5	VSTPOL	0	
6	HCKPOL	0	
7	VCKPOL	0	
8	BLKPOL	0	
9	PSTPOL	0	
10	DCKPOL	0	
11	CLRPOL	1	
12	ENBPOL	1	
13	SHSTPOL	1	
14	AUX2POL	0	
15	HCKWIDTH	2	
16	HSTPHASE	9	
17	HSTPOSH	0	
18	HSTPOL	7	
19	VSTPHASH	0	
20	VSTPHASL	0	
21	VSTPOS	11	
22	PCGPHASE	0	
23	PCGWIDTH	31	
24	PRGPHASE	0	
25	PRGWIDTH	18	
26	TGPOSHH	1	
27	TGPOSHL	4	
28	TGPHASVH	0	
29	TGPHASVL	0	
30	TGPOSV	44	

D9671CUR

Functionality		Data	Remarks
No.	Name		
0	CURBOLD	0	
1	FRMECLIP	1	
2	CROSSIZE	3	
3	CROSON	0	
4	RCROSON	1	
5	GCROSON	1	
6	BCROSON	1	
7	TOPON	0	
8	RTOPON	1	
9	GTOPON	1	
10	BTOPON	1	
11	BTOMON	0	
12	RBTO MON	1	
13	GBTOMON	1	
14	BBTOMON	1	
15	LEFTON	0	
16	RLEFTON	1	
17	GLEFTON	1	
18	BLEFTON	1	
19	RIGTON	0	
20	RRIGTON	1	
21	GRIGTON	1	
22	BRIGTON	1	
23	CRPOSHH	43	
24	CRPOSHL	5	
25	CRPOSVH	1	
26	CRPOSVL	137	
27	FRLEFTH	2	
28	FRLEFTL	3	
29	FRRIGTH	5	
30	FRRIGTL	71	
31	FRTOPH	1	
32	FRTOPL	7	
33	FRBOTMH	2	
34	FRBOTML	251	
35	RCURLVL	31	
36	GCURLVLH	3	
37	GCURLVLL	7	
38	BCURLVL	31	
39	RSMPSW	0	
40	RSMPPH	0	
41	RSMPPHPL	0	
42	RSMPPVPH	0	
43	RSMPPVPL	0	
44	RSMPSIZE	0	
45	RSMPPRIM	0	
46	RSMPCYCL	0	
47	RSMPPRILV	0	
48	RSMPPHLVR	0	
49	RSMPPHLVG	0	
50	RSMPPHLVB	0	
51	RSMPLLVR	0	
52	RSMPLLVG	0	
53	RSMPLLVB	0	

D9671TG2

Functionality		Data	Remarks
No.	Name		
0	FRPPHASE	255	
1	ENBPITCH	0	
2	CLRPTICH	0	
3	SHSTPITCH	0	
4	AUX2PITCH	0	
5	ENBPHASE	248	
6	ENBWIDTH	96	
7	PSTPOS	12	
8	PSTPHASE	2	
9	PSTWIDTH	11	
10	DCKPHASE	0	
11	DCKWIDTH	0	
12	CLRPHASE	232	
13	CLRWIDTH	47	
14	BLKPOS	0	
15	BLKWIDTH	0	
16	SHSTPHAS	217	
17	SHSTWIDT	128	
18	AUX2PHA	0	
19	AUX2WIDT	0	

D9671CSC

Functionality		Data	Remarks
No.	Name		
0	CSC00H	9	
1	CSC00L	145	
2	CSC01H	38	
3	CSC01L	15	
4	CSC02H	2	
5	CSC02L	65	
6	CSC10H	32	
7	CSC10L	7	
8	CSC11H	9	
9	CSC11L	240	
10	CSC12H	31	
11	CSC12L	5	
12	CSC20H	2	
13	CSC20L	34	
14	CSC21H	42	
15	CSC21L	9	
16	CSC22H	9	
17	CSC22L	29	
18	CSCCOR0H	63	
19	CSCCOR0L	189	
20	CSCCOR1H	0	
21	CSCCOR1L	17	
22	CSCCOR2H	0	
23	CSCCOR2L	22	
24	ASLSW	0	
25	ASLMODE	0	
26	ASLSLPR	0	
27	ASLSLPO	0	
28	ASLARP	0	
29	ASLARB	0	
30	ASLWAP	0	
31	ASLWAB	0	
32	ASLPLVLR	0	
33	ASLBLVLR	0	
34	ASLPLVLG	0	
35	ASLBLVLG	0	
36	ASLPLVLB	0	
37	ASLBLVLB	0	

A7001R

Functionality		Data	Remarks
No.	Name		
0	RGAINA	204	
1	RGAINB	32	
2	ROFSETA	165	
3	ROFSETB	32	
4	RCALLVL	12	
5	SHPOS	2	
6	RVCOM	43	
7	RSIDLVL	8	
8	S-RGAINA	204	
9	S-RGAINB	0	
10	S-ROFSETA	165	
11	S-ROFSETB	0	

A7001G

Functionality		Data	Remarks
No.	Name		
0	GGAINA	191	
1	GGAINB	32	
2	GOFSETA	144	
3	GOFSETB	32	
4	GCALLVL	12	
5	SHPOS	2	
6	GVCOM	43	
7	GSIDLVL	8	
8	S-GGAINA	191	
9	S-GGAINB	0	
10	S-GOFSETA	144	
11	S-GOFSETB	0	

A7001B

Functionality		Data	Remarks
No.	Name		
0	BGAINA	191	
1	BGAINB	32	
2	BOFSETA	144	
3	BOFSETB	32	
4	BCALLVL	12	
5	SHPOS	2	
6	BVCOM	40	
7	BSIDLVL	8	
8	S-BGAINA	191	
9	S-BGAINB	0	
10	S-BOFSETA	144	
11	S-BOFSETB	0	

SH SET

Functionality		Data	Remarks
No.	Name		
0	SH	0	
1	SHIFT SET	*1	

Standards *1

No.	Name	SH = 0	SH = 1	SH = 2	SH = 3	SH = 4	SH = 5	SH = 6
1	SHIFT SET	15	16	17	18	16	16	16

H POS SHI

Functionality		Data	Remarks
No.	Name		
0	VAR POS CTL	0	
1	SHPOS	*1	

Standards *1

No.	Name	VAR POS CTL = 0	VAR POS CTL = 1	VAR POS CTL = 2	VAR POS CTL = 3
1	SHPOS	8	6	6	4

No.	Name	VAR POS CTL = 4	VAR POS CTL = 5	VAR POS CTL = 6	VAR POS CTL = 7
1	SHPOS	4	2	2	0

No.	Name	VAR POS CTL = 8	VAR POS CTL = 9	VAR POS CTL = 10	VAR POS CTL = 11
1	SHPOS	0	10	10	8

No.	Name	VAR POS CTL = 12	VAR POS CTL = 13	VAR POS CTL = 14	VAR POS CTL = 15
1	SHPOS	8	6	6	4

TEMP

Functionality		Data	Remarks
No.	Name		
0	SET	59	
1	TIME	10	
2	PON-TIME	0	
3	PON-TEMP	*1	
4	TEMP	0	
5	OFFSET	*2	

Standards *1

No.	Name	PON-TIME=0	PON-TIME=1	PON-TIME=2	PON-TIME=3
3	PON-TEMP	141	141	141	141

No.	Name	PON-TIME=4	PON-TIME=5	PON-TIME=6	PON-TIME=7
3	PON-TEMP	141	140	140	138

No.	Name	PON-TIME=8	PON-TIME=9	PON-TIME=10	PON-TIME=11
3	PON-TEMP	138	136	136	135

No.	Name	PON-TIME=12	PON-TIME=13	PON-TIME=14	PON-TIME=15
3	PON-TEMP	135	134	134	134

No.	Name	PON-TIME=16	PON-TIME=17	PON-TIME=18	PON-TIME=19
3	PON-TEMP	133	133	133	132

No.	Name	PON-TIME=20	PON-TIME=21	PON-TIME=22	PON-TIME=23
3	PON-TEMP	132	131	131	131

No.	Name	PON-TIME=24	PON-TIME=25	PON-TIME=26	PON-TIME=27
3	PON-TEMP	131	130	130	130

No.	Name	PON-TIME=28	PON-TIME=29	PON-TIME=30
3	PON-TEMP	129	128	128

Standards *2

No.	Name	TEMP=0	TEMP=1	TEMP=2	TEMP=3
5	OFFSET	113	113	113	113

No.	Name	TEMP=4	TEMP=5	TEMP=6	TEMP=7
5	OFFSET	113	113	113	113

No.	Name	TEMP=8	TEMP=9	TEMP=10	TEMP=11
5	OFFSET	113	113	113	113

No.	Name	TEMP=12	TEMP=13	TEMP=14	TEMP=15
5	OFFSET	113	113	113	113

No.	Name	TEMP=16	TEMP=17	TEMP=18	TEMP=19
5	OFFSET	113	113	113	113

No.	Name	TEMP=20	TEMP=21	TEMP=22	TEMP=23
5	OFFSET	113	113	113	113

No.	Name	TEMP=24	TEMP=25	TEMP=26	TEMP=27
5	OFFSET	113	113	113	114

No.	Name	TEMP=28	TEMP=29	TEMP=30	TEMP=31
5	OFFSET	115	115	116	117

No.	Name	TEMP=32	TEMP=33	TEMP=34	TEMP=35
5	OFFSET	117	118	119	119

No.	Name	TEMP=36	TEMP=37	TEMP=38	TEMP=39
5	OFFSET	120	121	121	122

No.	Name	TEMP=40	TEMP=41	TEMP=42	TEMP=43
5	OFFSET	123	123	124	125

No.	Name	TEMP=44	TEMP=45	TEMP=46	TEMP=47
5	OFFSET	125	126	127	127

No.	Name	TEMP=48	TEMP=49	TEMP=50	TEMP=51
5	OFFSET	128	129	129	130

No.	Name	TEMP=52	TEMP=53	TEMP=54	TEMP=55
5	OFFSET	131	131	132	133

No.	Name	TEMP=56	TEMP=57	TEMP=58	TEMP=59
5	OFFSET	133	134	135	135

No.	Name	TEMP=60	TEMP=61	TEMP=62	TEMP=63
5	OFFSET	136	137	138	138

No.	Name	TEMP=64	TEMP=65	TEMP=66	TEMP=67
5	OFFSET	139	140	140	141

No.	Name	TEMP=68	TEMP=69	TEMP=70	TEMP=71
5	OFFSET	142	142	143	143

No.	Name	TEMP=72	TEMP=73	TEMP=74	TEMP=75
5	OFFSET	143	143	143	143

No.	Name	TEMP=76	TEMP=77	TEMP=78	TEMP=79
5	OFFSET	143	143	143	143

No.	Name	TEMP=80
5	OFFSET	143

OSD-E

Functionality		Data		Remarks
No.	Name	NORMAL	WIDE	
0	VPOS	21	21	
1	HPOS	4	4	

OPTION-E

Functionality		Data	Remarks
No.	Name		
0	LAMP TIME	-	
1	LAMP OFF	1	
2	FAN OFF	0	
3	FAN1 RPM	0	
4	FAN2 RPM	0	
5	FAN3 RPM	0	
6	FAN4 RPM	0	
7	FAN5 RPM	0	
8	FLAG1	0	
9	AGING PT	0	
10	TEMP SHIFT	1	
11	ADJ	0	
12	P CTL SHT1	10	
13	P CTL SHT2	0	
14	P CTL SHT3	0	
15	P CTL ADD	0	
16	LVDS-WAIT	0	
17	GAM-WAIT	1	

FAN-CTL

Functionality		Data	Remarks
No.	Name		
0	TEMP-ERR	70	
1	FAN1-KICK	186	
2	FAN2-KICK	239	
3	FAN3-KICK	255	
4	FAN10-START	27	
5	FAN10-END	32	
6	FAN10-VMAX	252	
7	FAN10-VMIN	125	
8	FAN11-START	27	
9	FAN11-END	32	
10	FAN11-VMAX	252	
11	FAN11-VMIN	125	
12	FAN12-START	27	
13	FAN12-END	32	
14	FAN12-VMAX	235	
15	FAN12-VMIN	125	
16	FAN13-START	27	
17	FAN13-END	32	
18	FAN13-VMAX	235	
19	FAN13-VMIN	125	
20	FAN20-START	27	
21	FAN20-END	32	
22	FAN20-VMAX	179	
23	FAN20-VMIN	10	
24	FAN21-START	27	
25	FAN21-END	32	
26	FAN21-VMAX	179	
27	FAN21-VMIN	10	
28	FAN22-START	27	
29	FAN22-END	32	
30	FAN22-VMAX	125	
31	FAN22-VMIN	10	
32	FAN23-START	27	
33	FAN23-END	32	
34	FAN23-VMAX	125	
35	FAN23-VMIN	10	
36	FAN30-START	27	
37	FAN30-END	32	
38	FAN30-VMAX	252	
39	FAN30-VMIN	125	
40	FAN31-START	27	
41	FAN31-END	32	
42	FAN31-VMAX	252	
43	FAN31-VMIN	125	
44	FAN32-START	27	
45	FAN32-END	32	
46	FAN32-VMAX	204	
47	FAN32-VMIN	125	
48	FAN33-START	27	
49	FAN33-END	32	
50	FAN33-VMAX	204	
51	FAN33-VMIN	125	

GB RGB

Functionality		Data	Remarks
No.	Name		
0	KURG	0	
1	KUGG	0	
2	KUBG	0	
3	KURB	0	
4	KUGB	0	
5	KUBB	0	

SECTION 4
DIAGRAMS

4-1. BLOCK DIAGRAM (1)

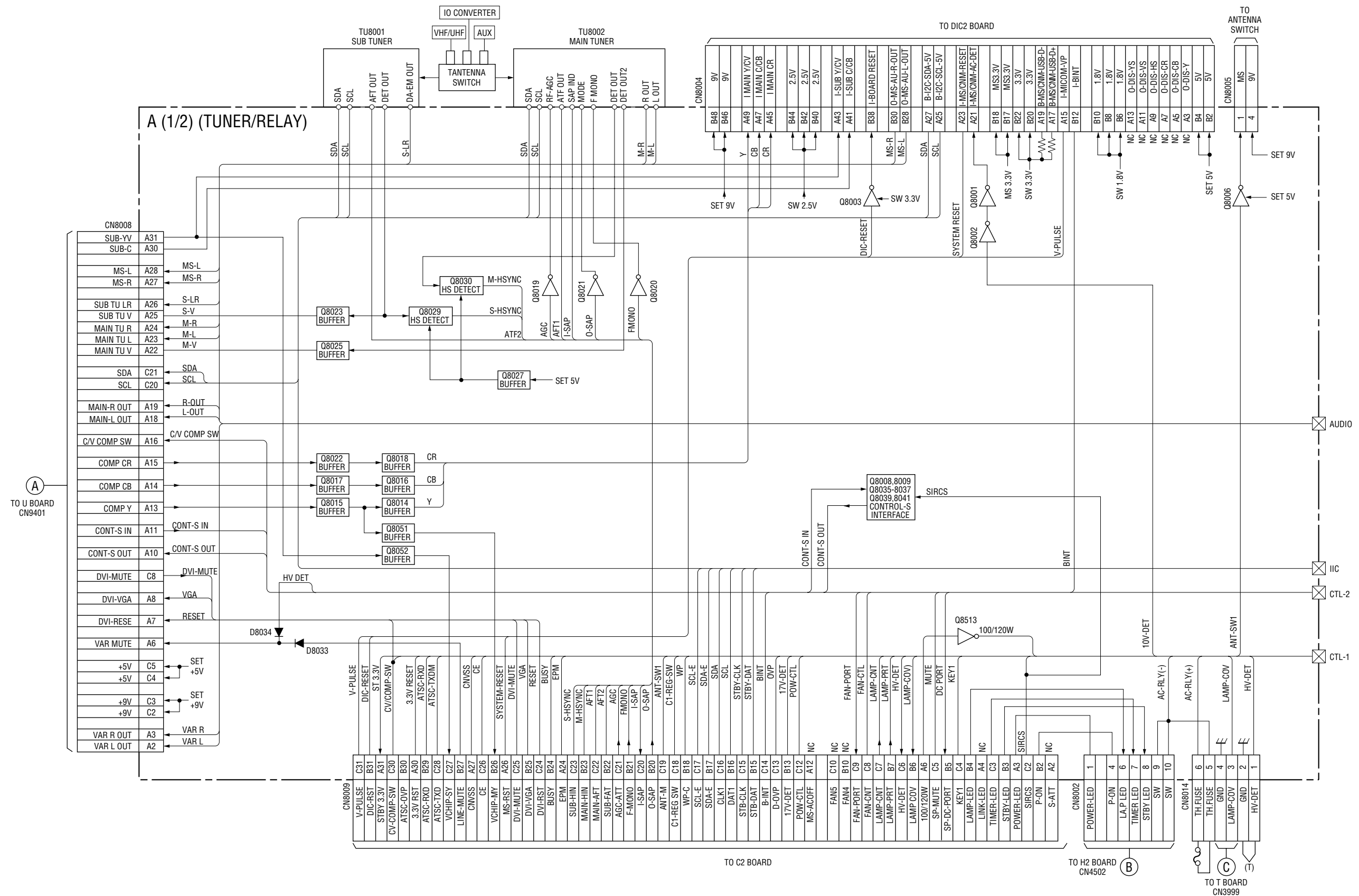

BLOCK DIAGRAM (2)

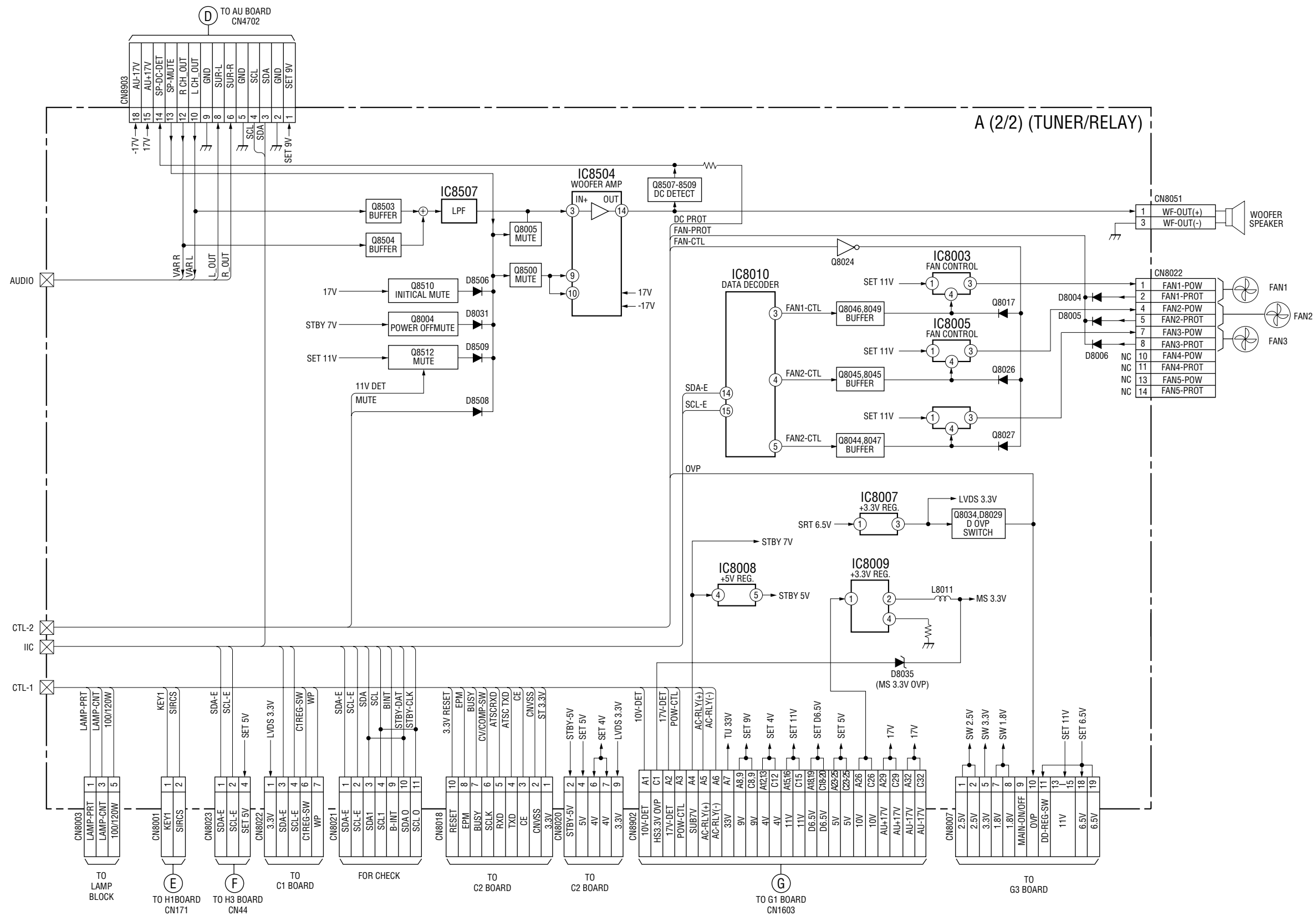

BLOCK DIAGRAM (3)

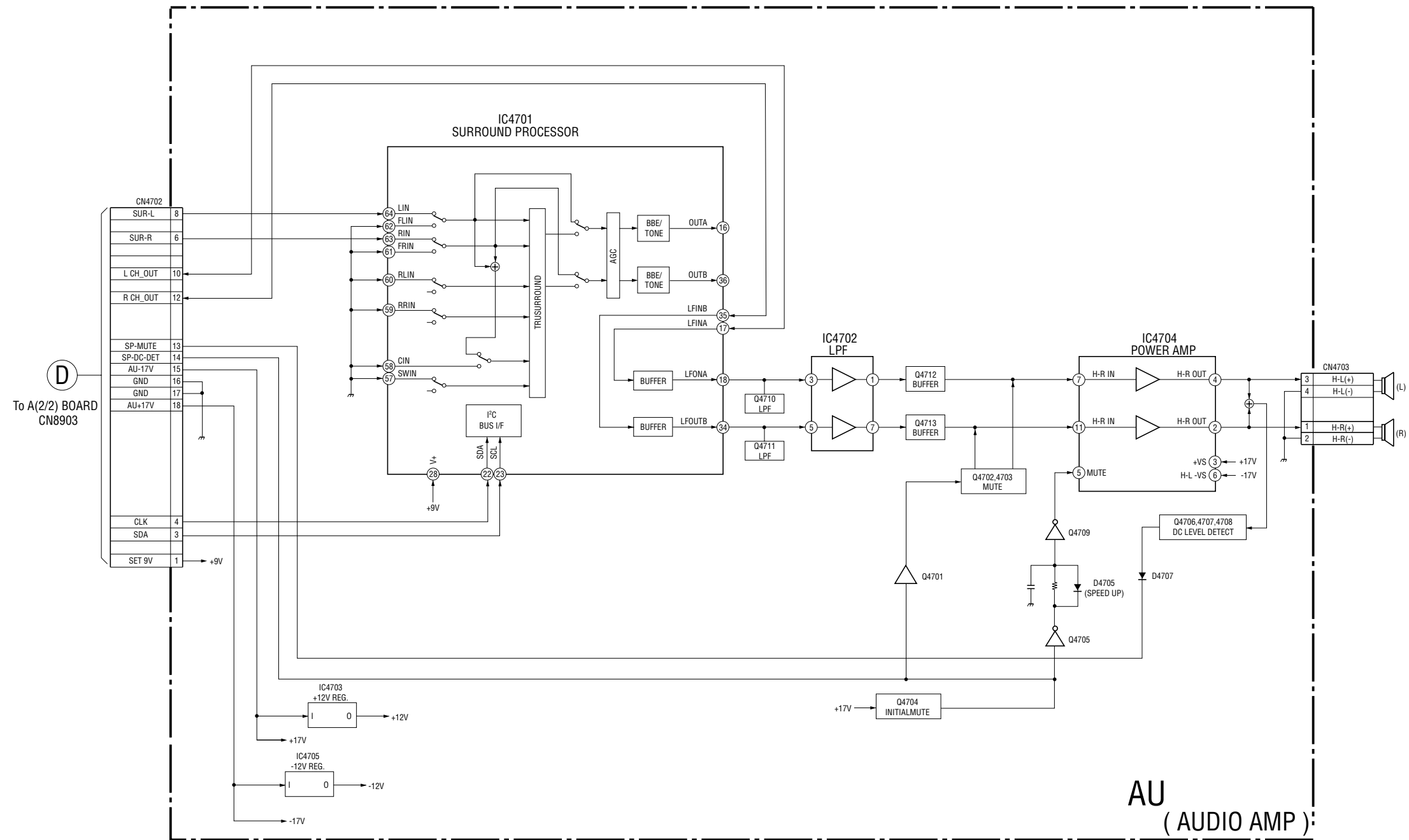

BLOCK DIAGRAM (4)

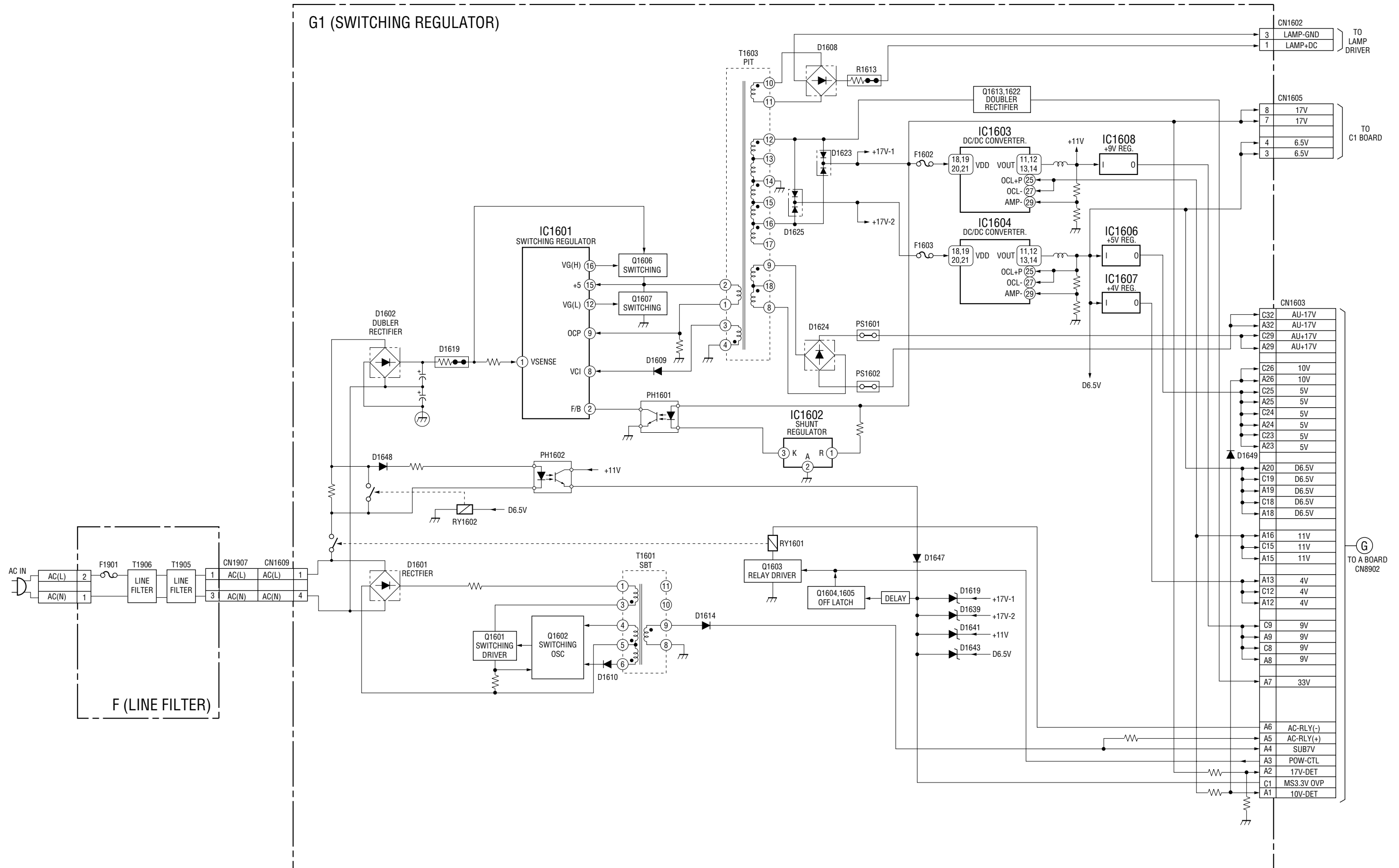

BLOCK DIAGRAM (5)

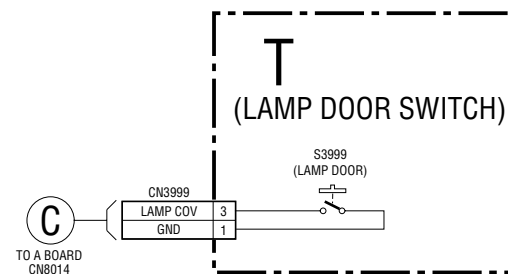
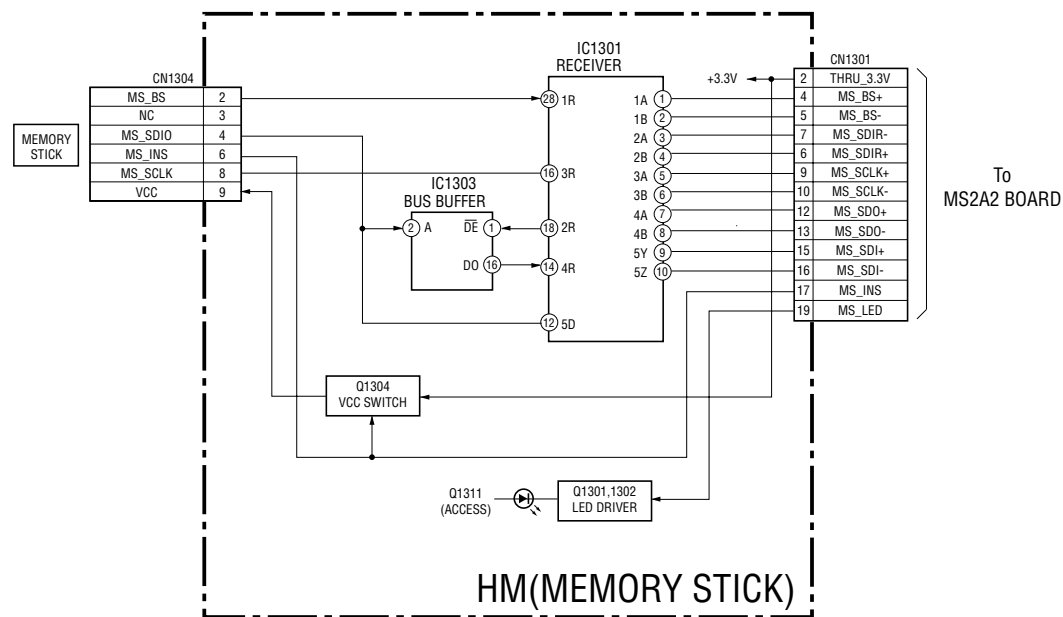
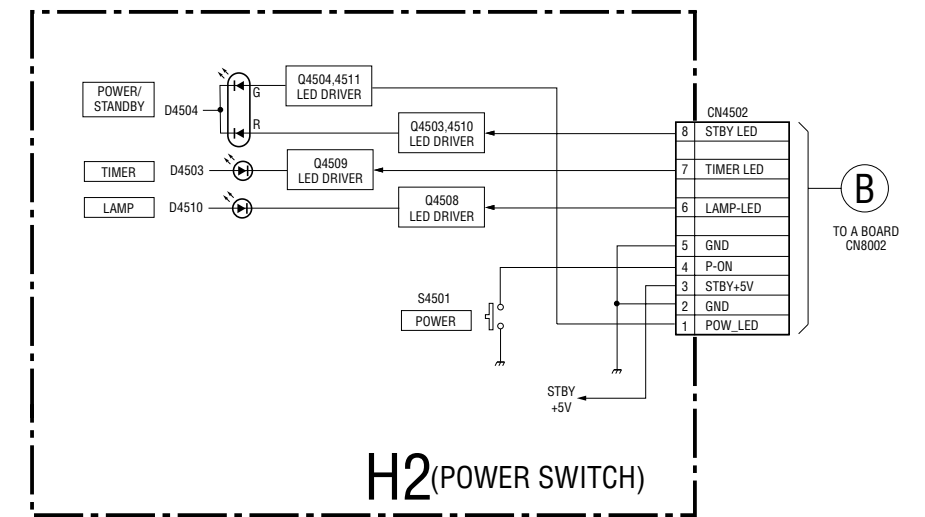
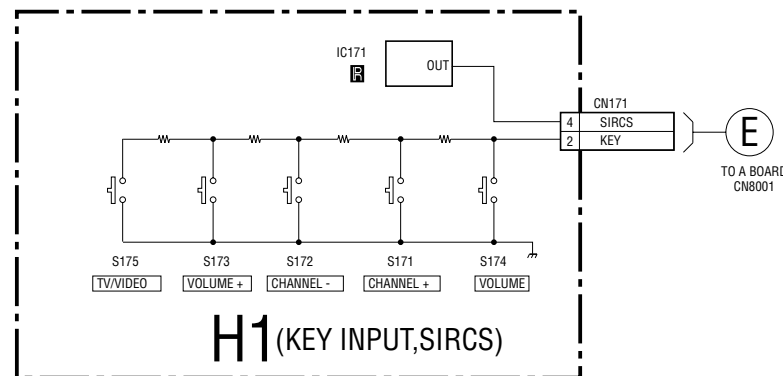
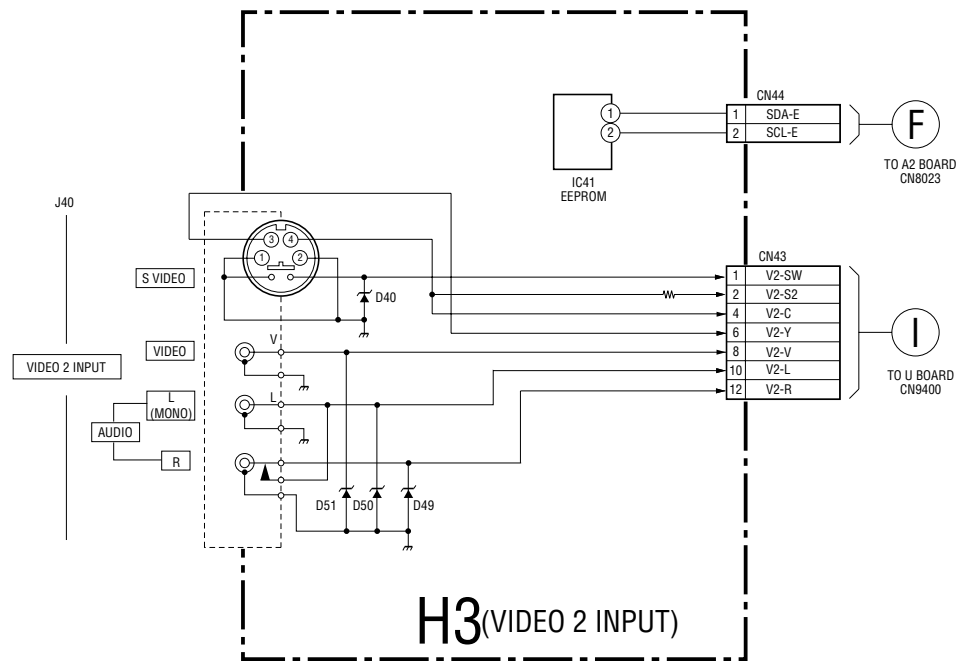

BLOCK DIAGRAM (6)

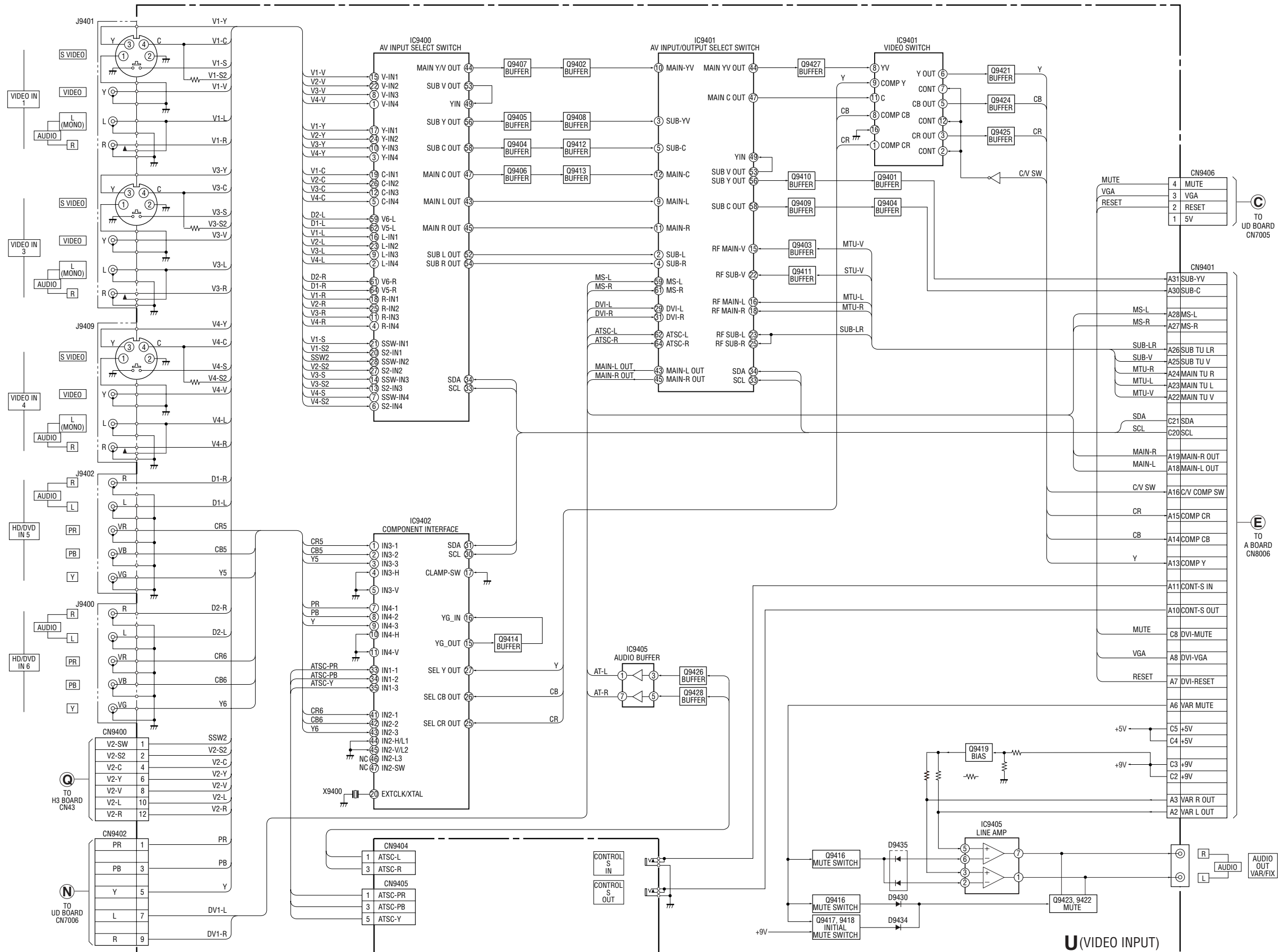

BLOCK DIAGRAM (7)

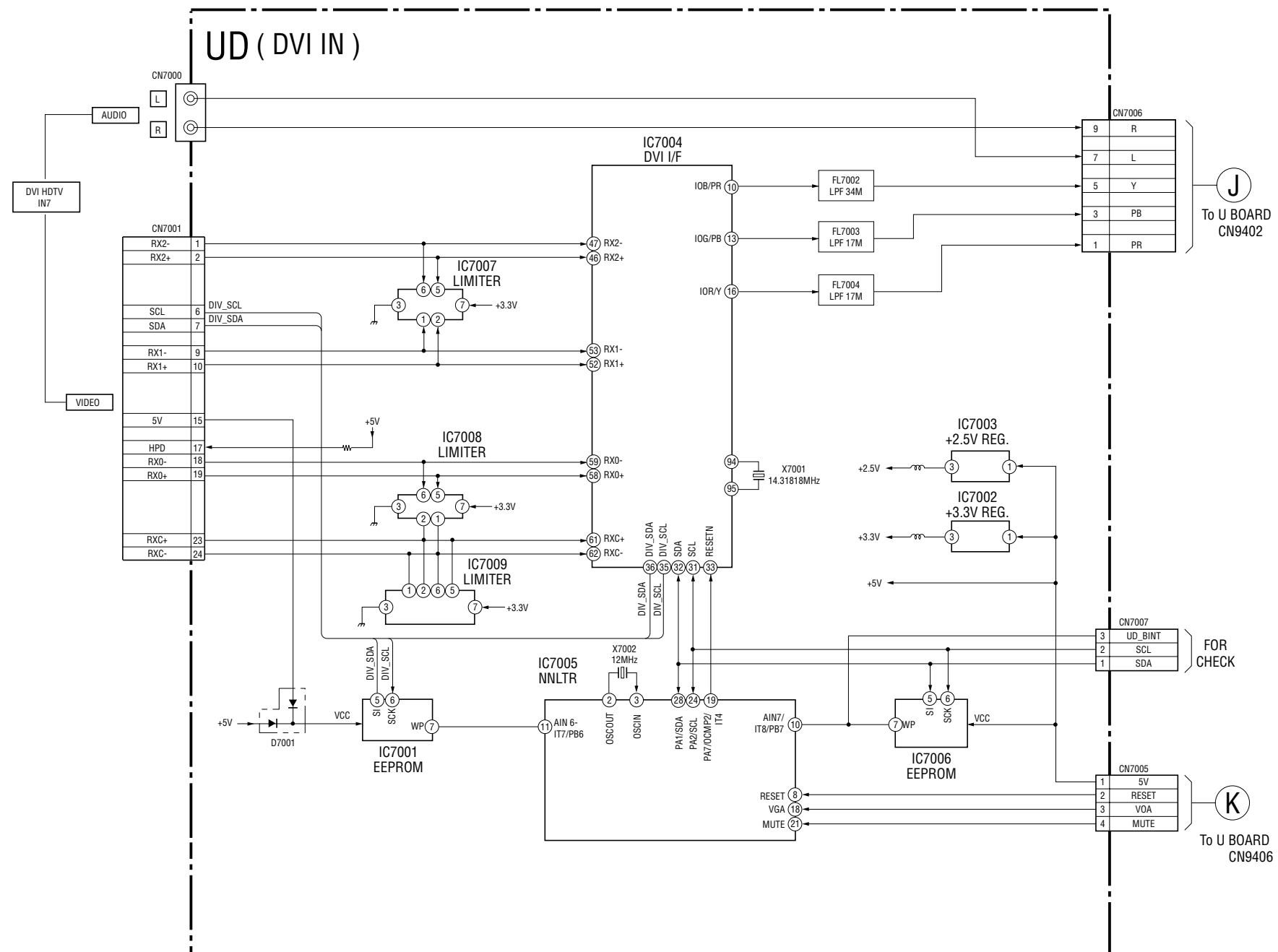

4-2. FRAME SCHEMATIC DIAGRAM

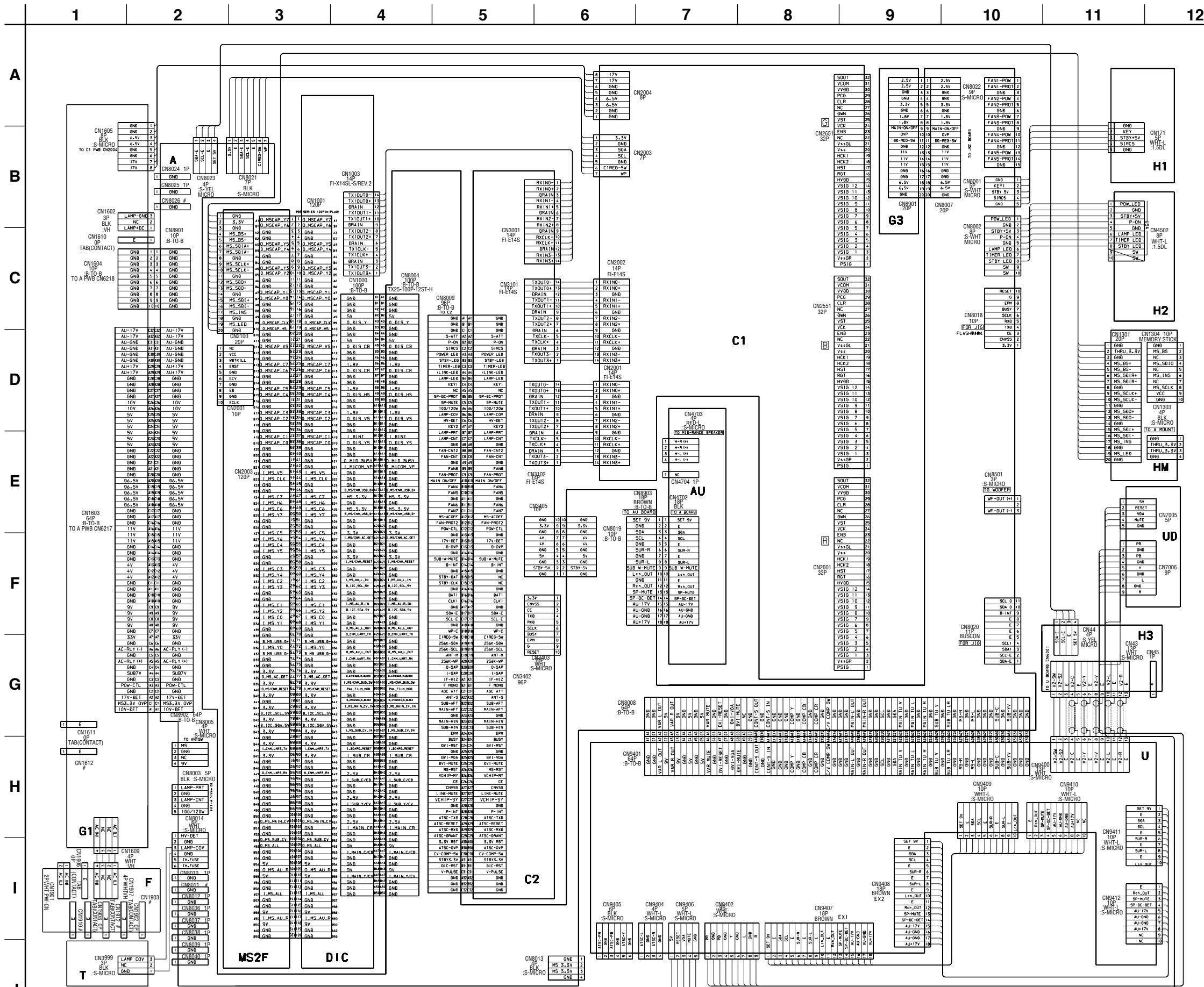

4-3. CIRCUIT BOARDS LOCATION

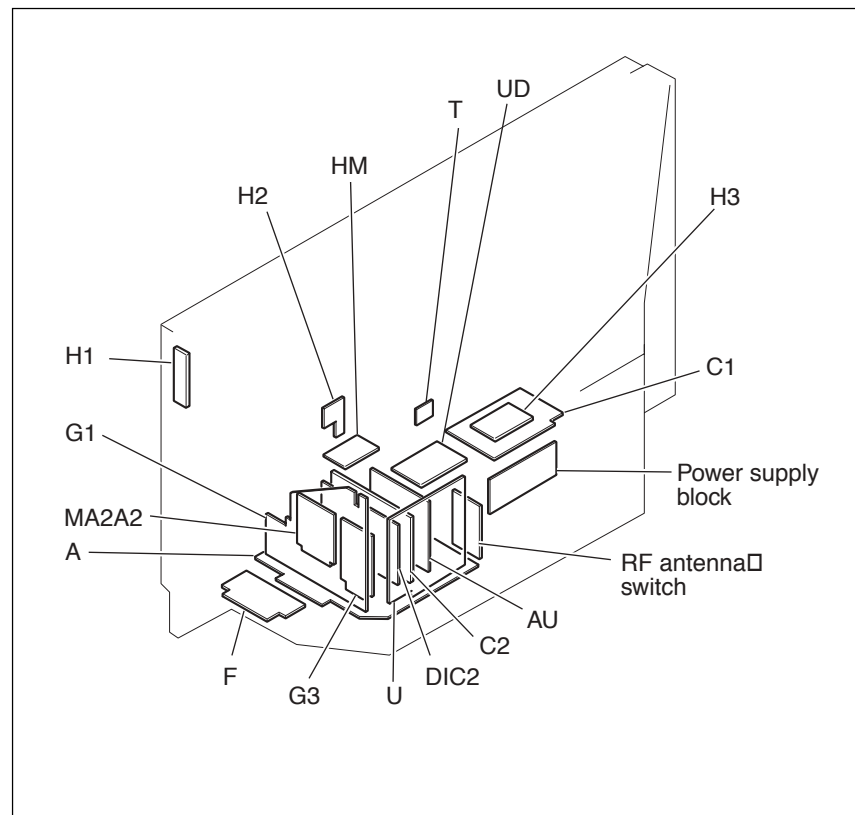

4-4. SCHEMATIC DIAGRAMS

Note:

- The parts marked “#” on schematic diagrams are not mounted.
- All capacitors are in μF unless otherwise noted. (pF: μpF) Capacitors without voltage indication are all 50 V.
- Indication of resistance, which does not have one for rating electrical power, is as follows.

Pitch: 5 mm
Rating electrical power 1/4 W (CHIP : 1/10 W)

- All resistors are in ohms.
- : nonflammable resistor.
- : fusible resistor.
- : internal component.
- : panel designation, and adjustment for repair.
- All variable and adjustable resistors have characteristic curve B, unless otherwise noted.
- : earth-ground.
- : earth-chassis.
- All voltages are in V.
- Readings are taken with a 10 M Ω digital multimeter.
- Readings are taken with a color-bar signal input.
- Voltage variations may be noted due to normal production tolerances.
- * : Can not be measured.
- Circled numbers are waveform references.
- : B + bus.
- : B - bus.
- : Signal path.

- Divided schematic diagram
- Schematic diagrams of A, BB, BC, M and U boards are divided □ into several pieces. Information to where the line is to be connected □ is printed at the end of each line. □
- For example, [TO A1/3,A2/3_1] means the line is connected to □ Ref. No. 1 of A (1/3) and A (2/3) schematic diagrams. □

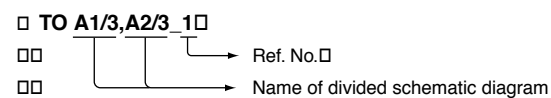

Reference information

RESISTOR	: RN	METAL FILM
	: RC	SOLID
	: FPRD	NONFLAMMABLE CARBON
	: FUSE	NONFLAMMABLE FUSIBLE
	: RW	NONFLAMMABLE WIREWOUND
	: RS	NONFLAMMABLE METAL OXIDE
	: RB	NONFLAMMABLE CEMENT
COIL	: LF-8L	MICRO INDUCTOR
CAPACITOR	: TA	TANTALUM
	: PS	STYROL
	: PP	POLYPROPYLENE
	: PT	MYLAR
	: MPS	METALIZED POLYESTER
	: MPP	METALIZED POLYPROPYLENE
	: ALB	BIPOLAR
	: ALT	HIGH TEMPERATURE
	: ALR	HIGH RIPPLE

Note: The components identified by shading and mark are critical for safety. Replace only with part number specified.

Terminal name of semiconductors in silk screen printed circuit (※)

Device	Printed symbol	Terminal name	Circuit
① Transistor		Collector Base Emitter	
② Transistor		Collector Base Emitter	
③ Diode		Cathode Anode	
④ Diode		Cathode Anode (NC)	
⑤ Diode		Cathode Anode (NC)	
⑥ Diode		Common Anode Cathode	
⑦ Diode		Common Anode Cathode	
⑧ Diode		Common Anode Anode	
⑨ Diode		Common Anode Anode	
⑩ Diode		Common Cathode Cathode	
⑪ Diode		Common Cathode Cathode	
⑫ Diode		Anode Cathode Anode Cathode	
⑬ Transistor (FET)		Drain Source Gate	
⑭ Transistor (FET)		Drain Source Gate	
⑮ Transistor (FET)		Source Drain Gate	
⑯ Transistor		Emitter Collector Base	
⑰ Transistor		C2/B1/E1 E2/B2/C1	
⑱ Transistor		C1/B2/E2 E1/B1/C2	
⑲ Transistor		C1 B2 E2 E1 B1 C2	
⑳ Transistor		C1 B2 E2 E1 B1 C2	
㉑ Transistor		E2 B1 E1 C2 C1(B2)	
㉒ Transistor		(B2) B1 E1 E2 C1 C2	
㉓ Transistor		(B2) B1 E1 E2 C1 C2	
— Discrete semiconductor			

(Chip semiconductors that are not actually used are included.)

Ver.1.5

(1) Schematic Diagram of A (1/4) Board

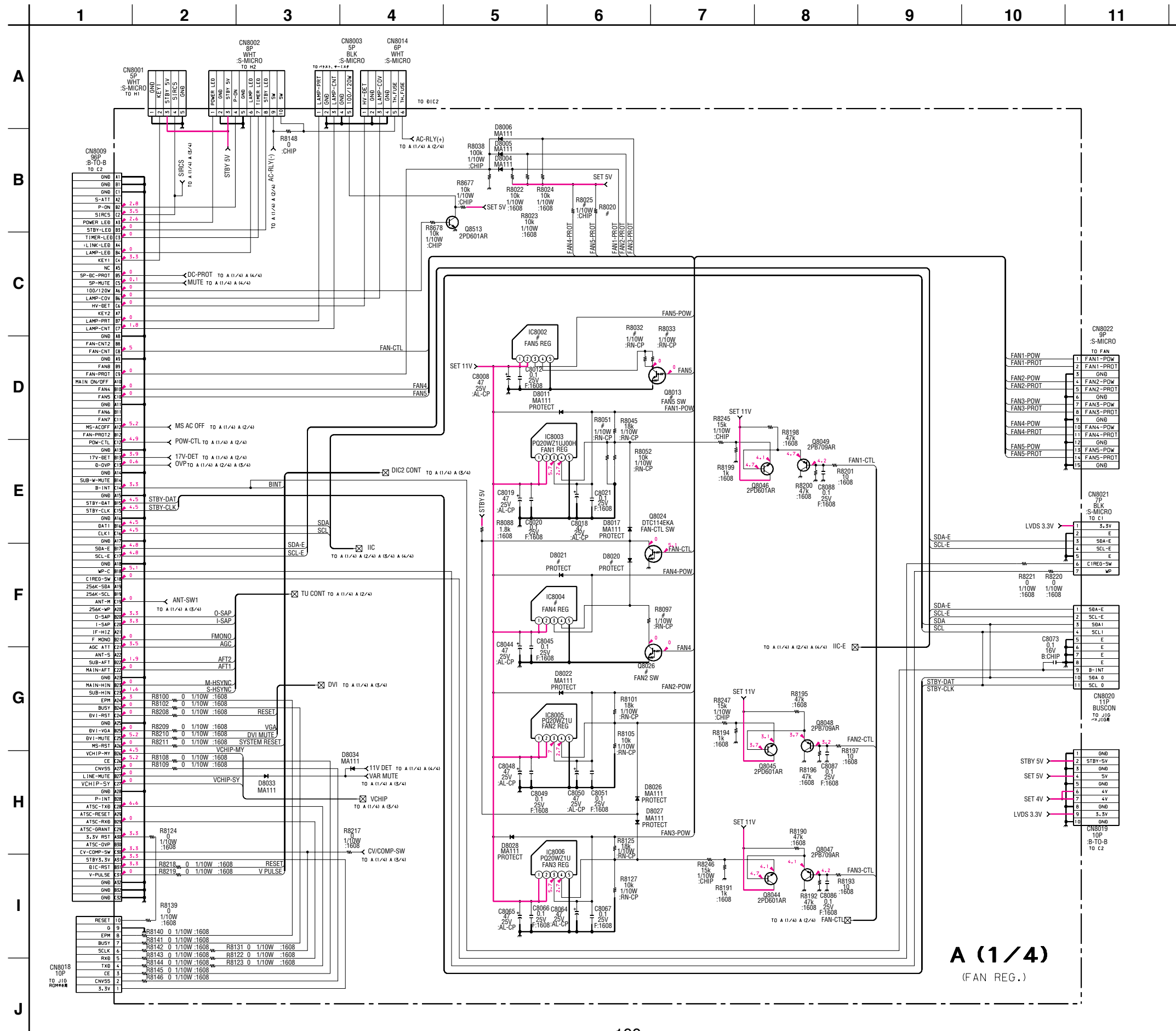

(2) Schematic Diagram of A (2/4) Board

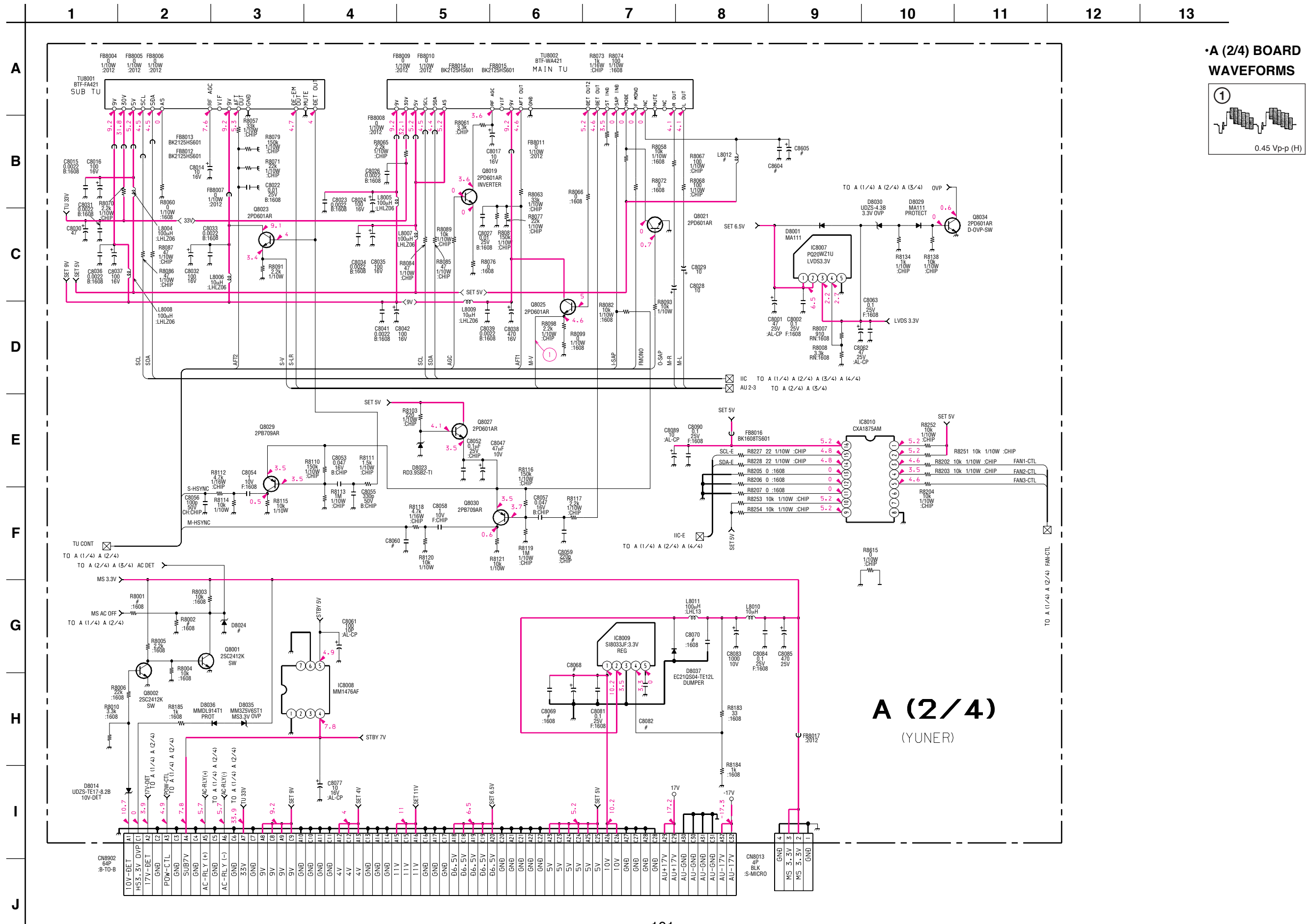

•A (2/4) BOARD WAVEFORMS

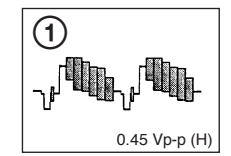

(3) Schematic Diagram of A (3/4) Board

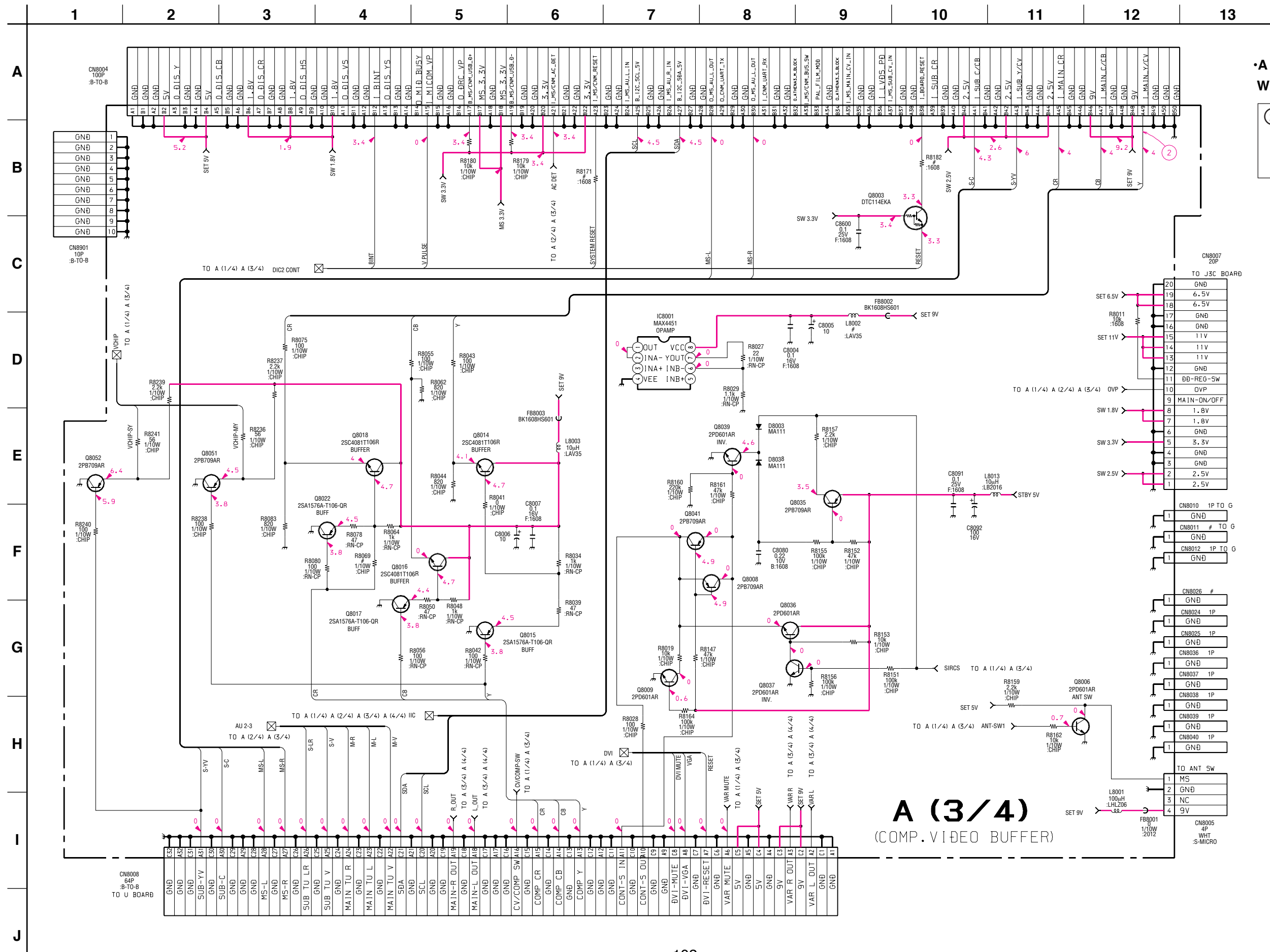

• A (3/4) BOARD WAVEFORMS

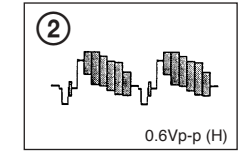

A (3/4) (COMP. VIDEO BUFFER)

(4) Schematic Diagram of A (4/4) Board

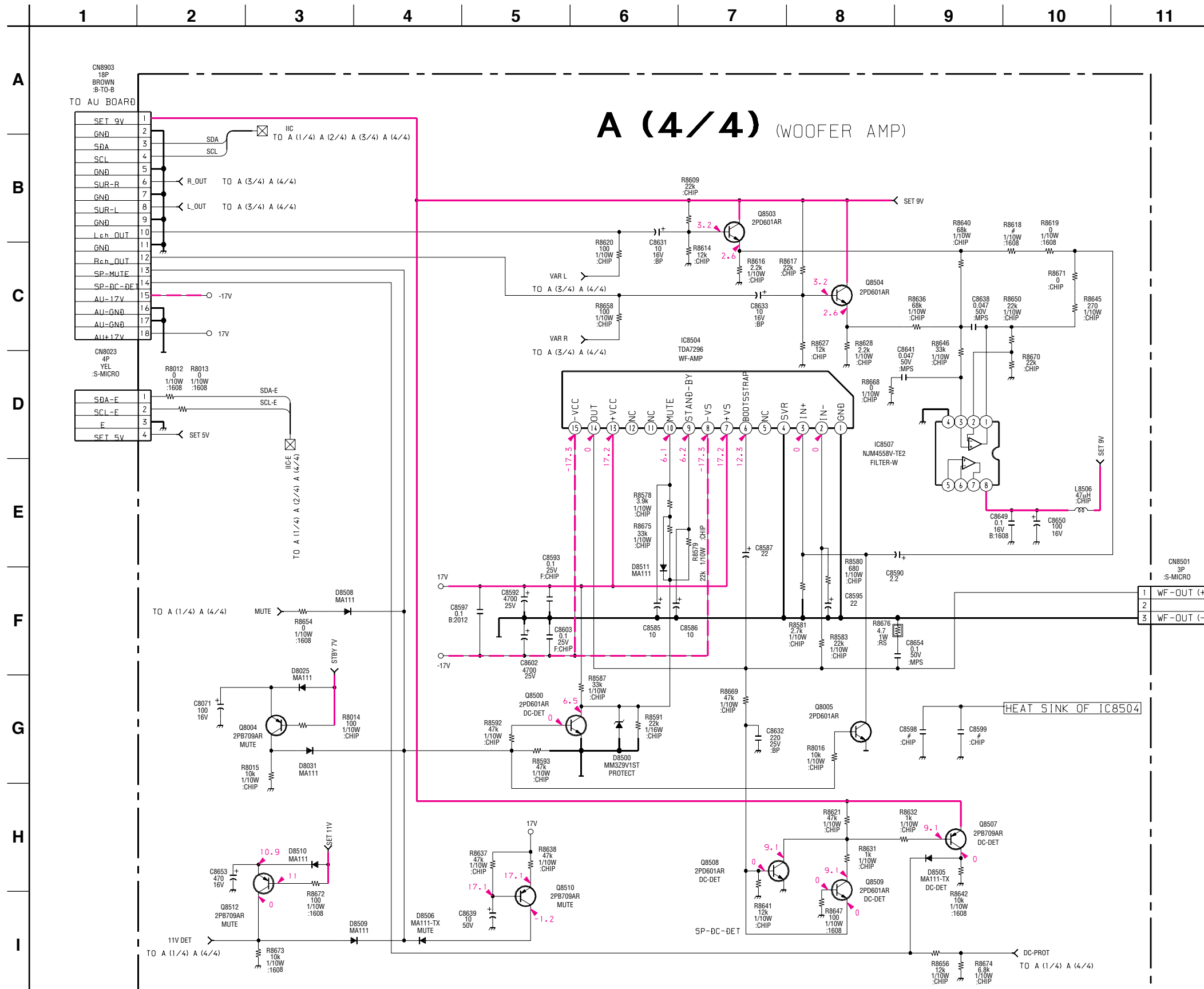

(5) Schematic Diagram of AU (1/2) Board

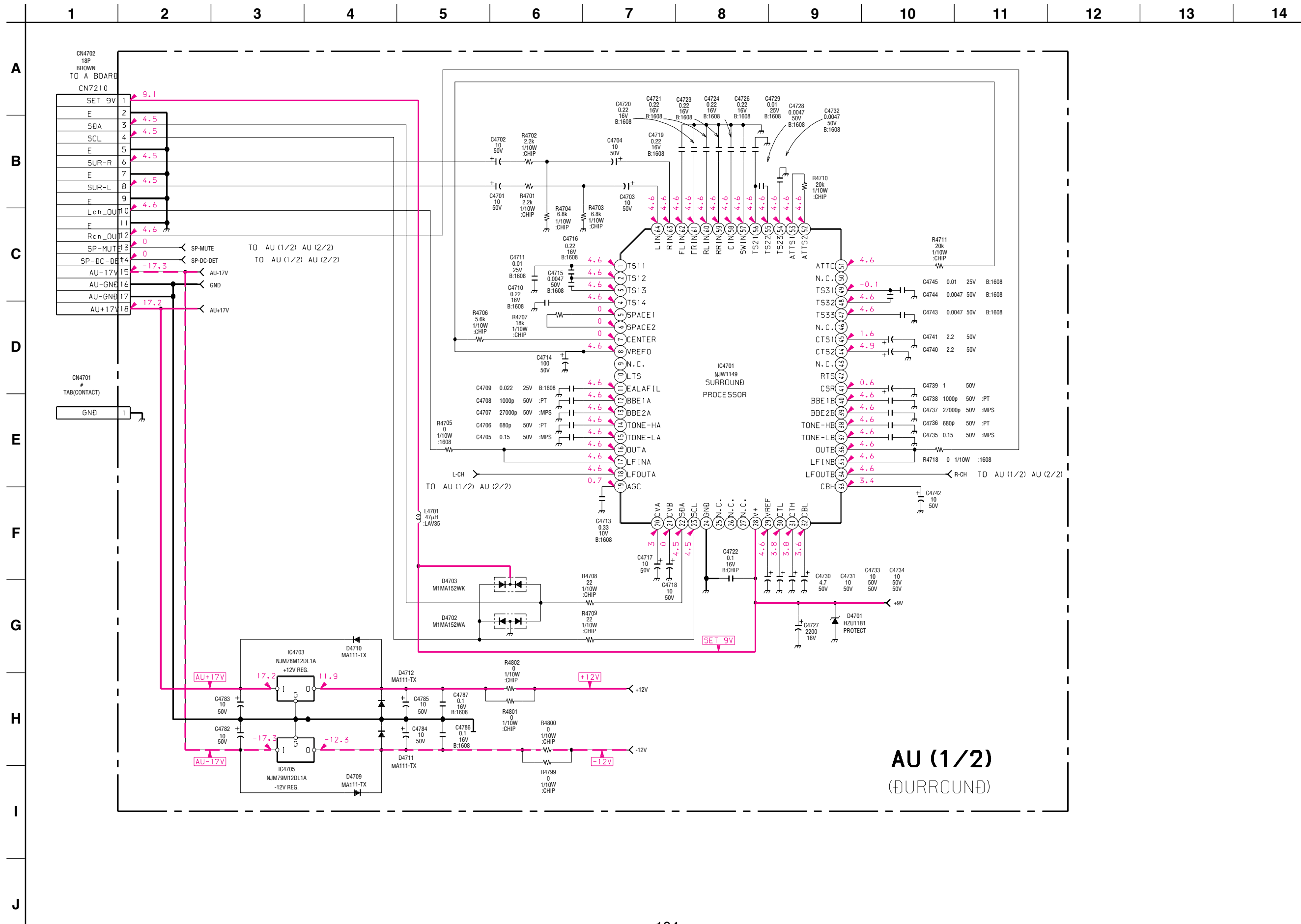

(6) Schematic Diagram of AU (2/2) Board

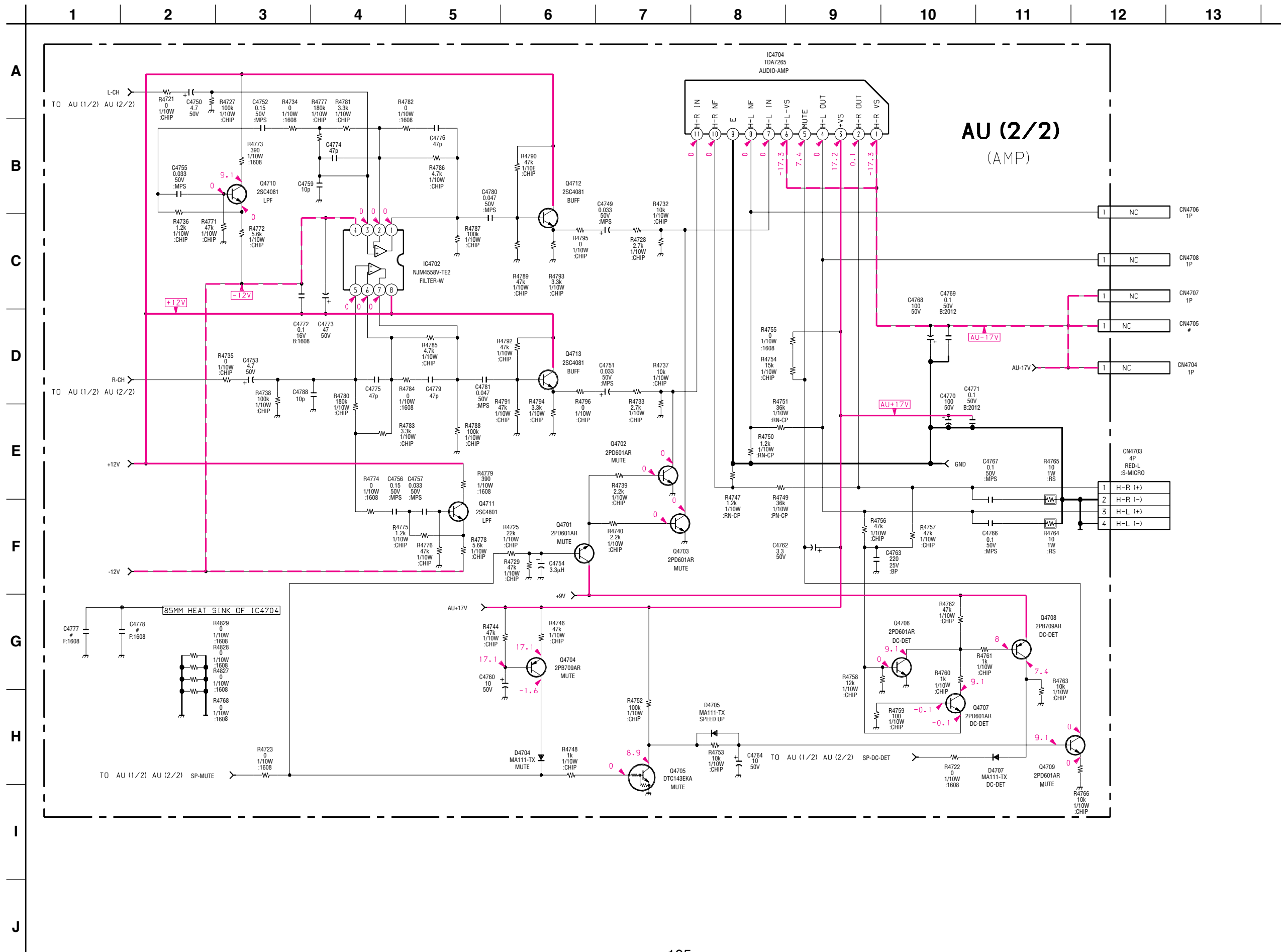

(7) Schematic Diagram of F Board

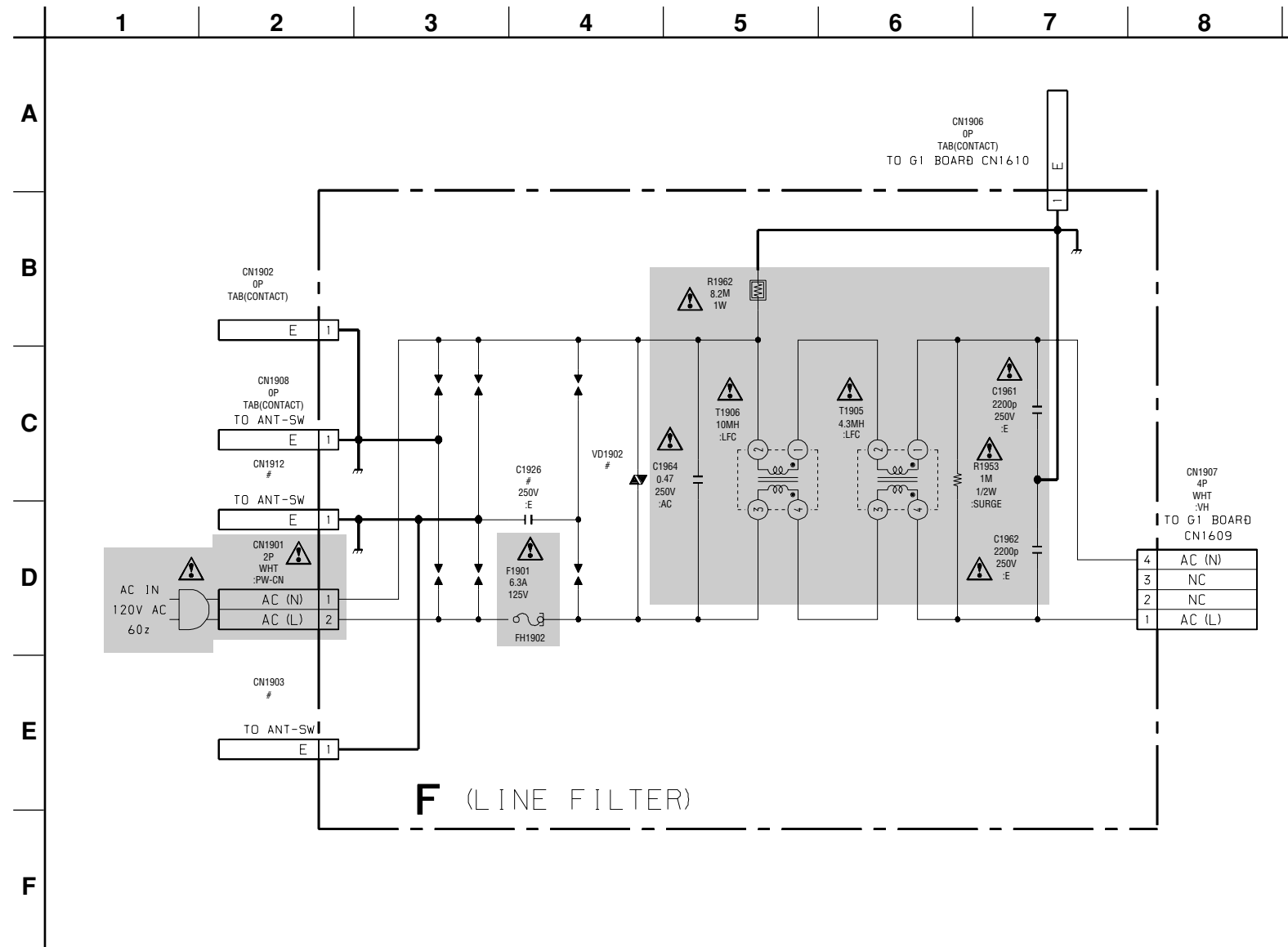

4	AC (N)
3	NC
2	NC
1	AC (L)

(8) Schematic Diagram of G1 Board

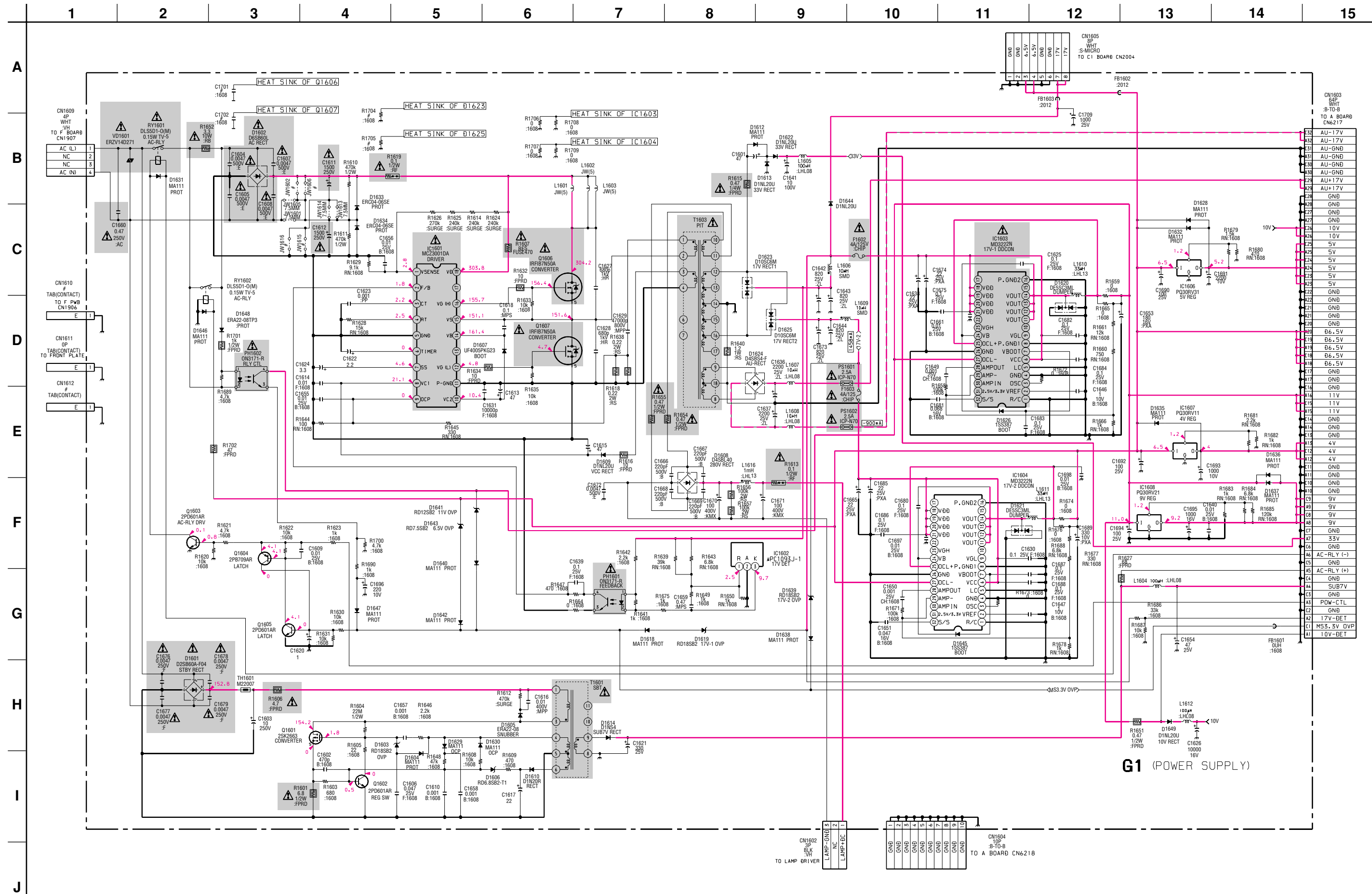

G1 (POWER SUPPLY)

(9) Schematic Diagram of H1, H2 Board

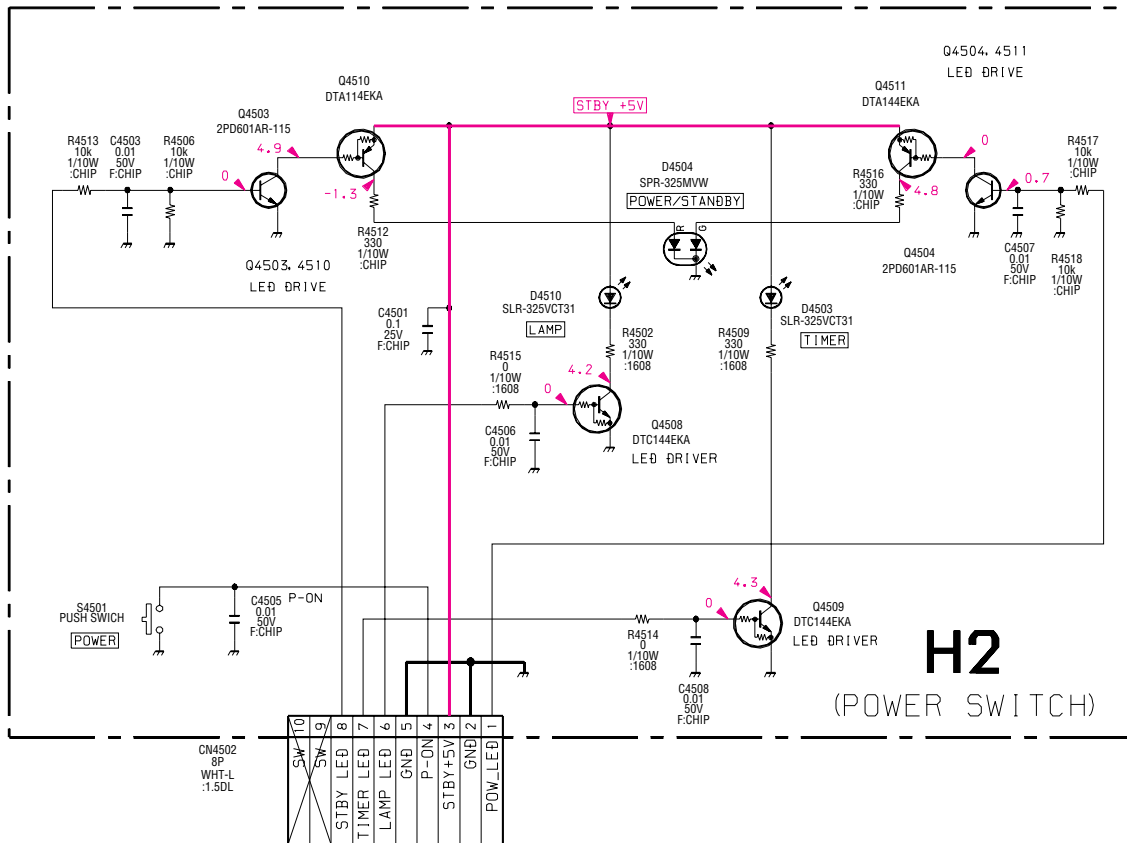
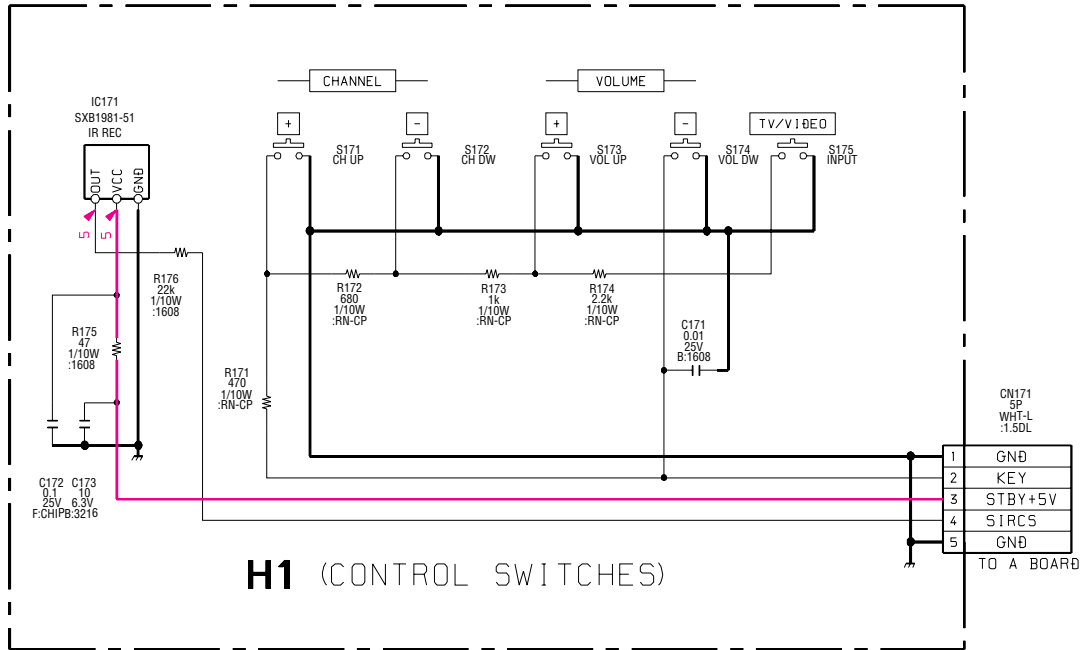

(10) Schematic Diagram of H3 Board

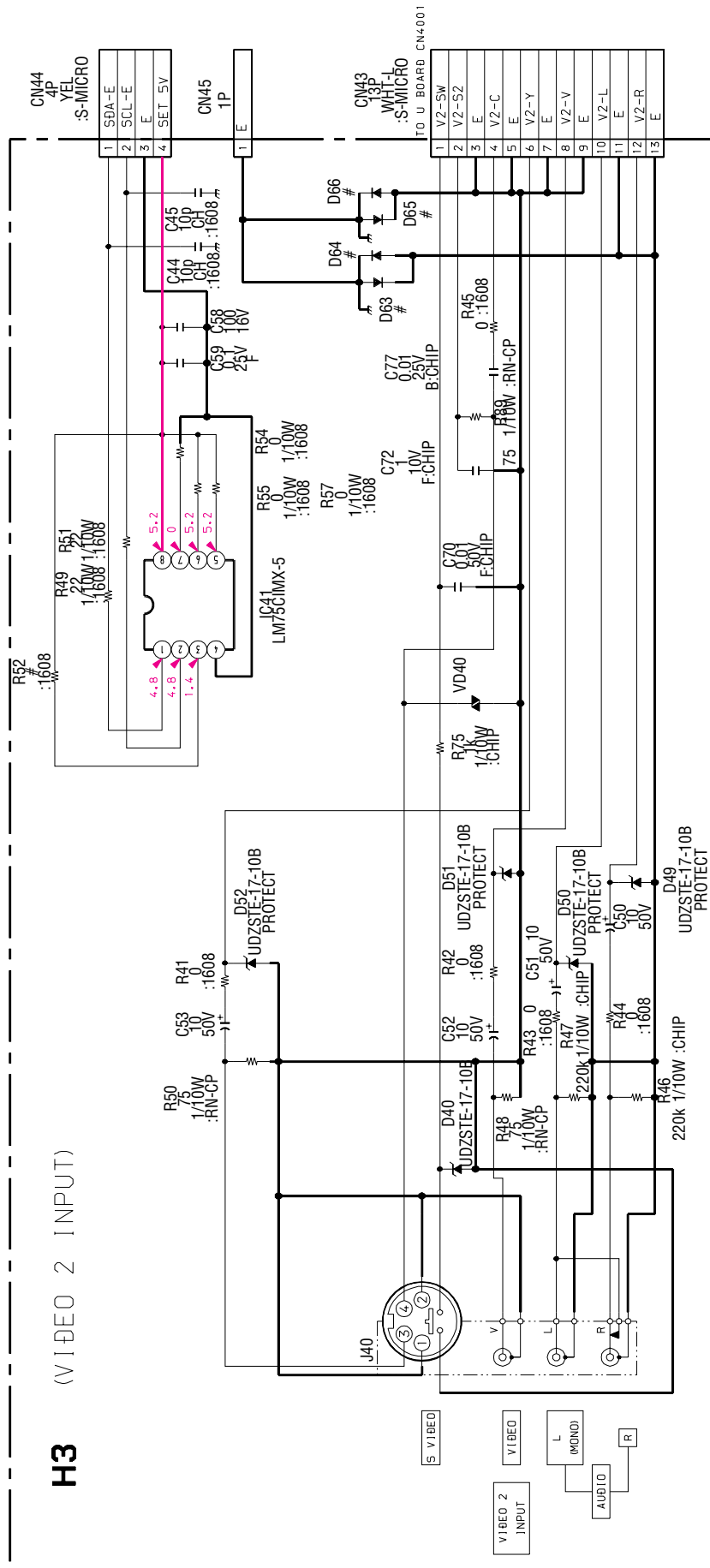

(11) Schematic Diagram of HM Board

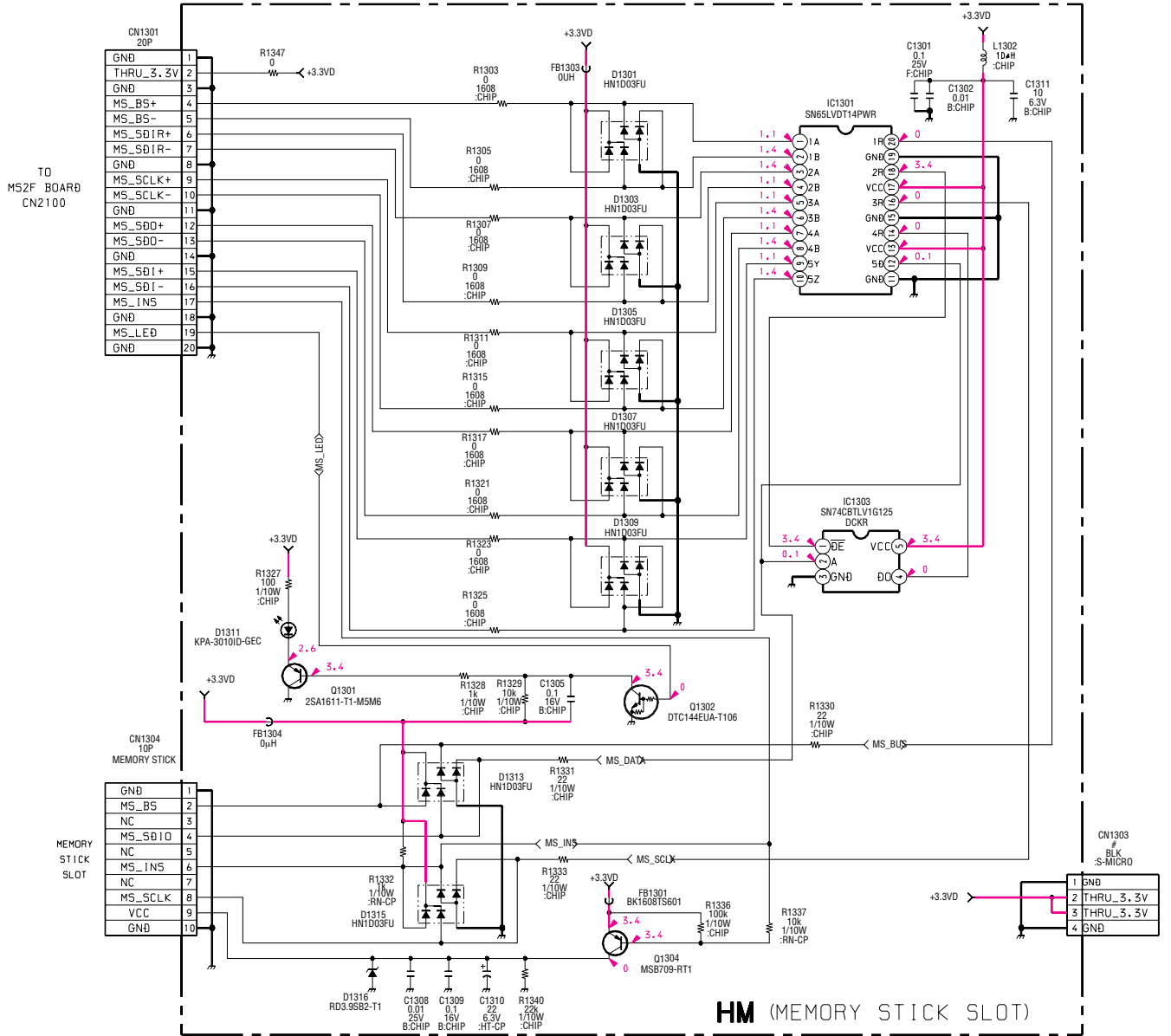

HM (MEMORY STICK SLOT)

(12) Schematic Diagram of T Board

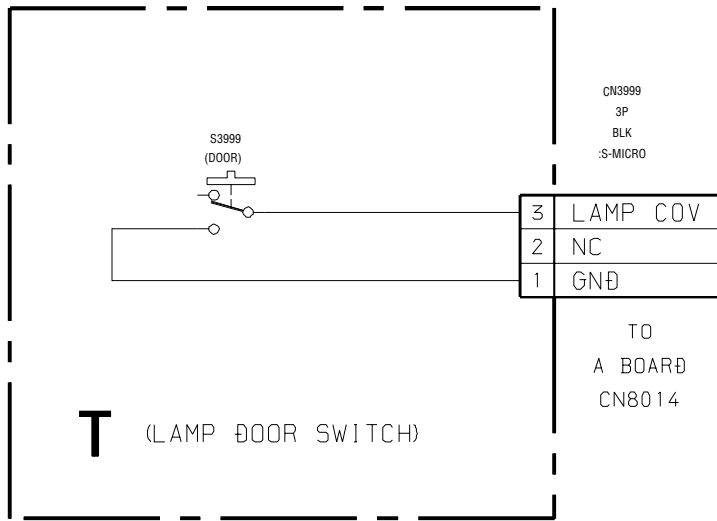

(13) Schematic Diagram of U (1/3) Board

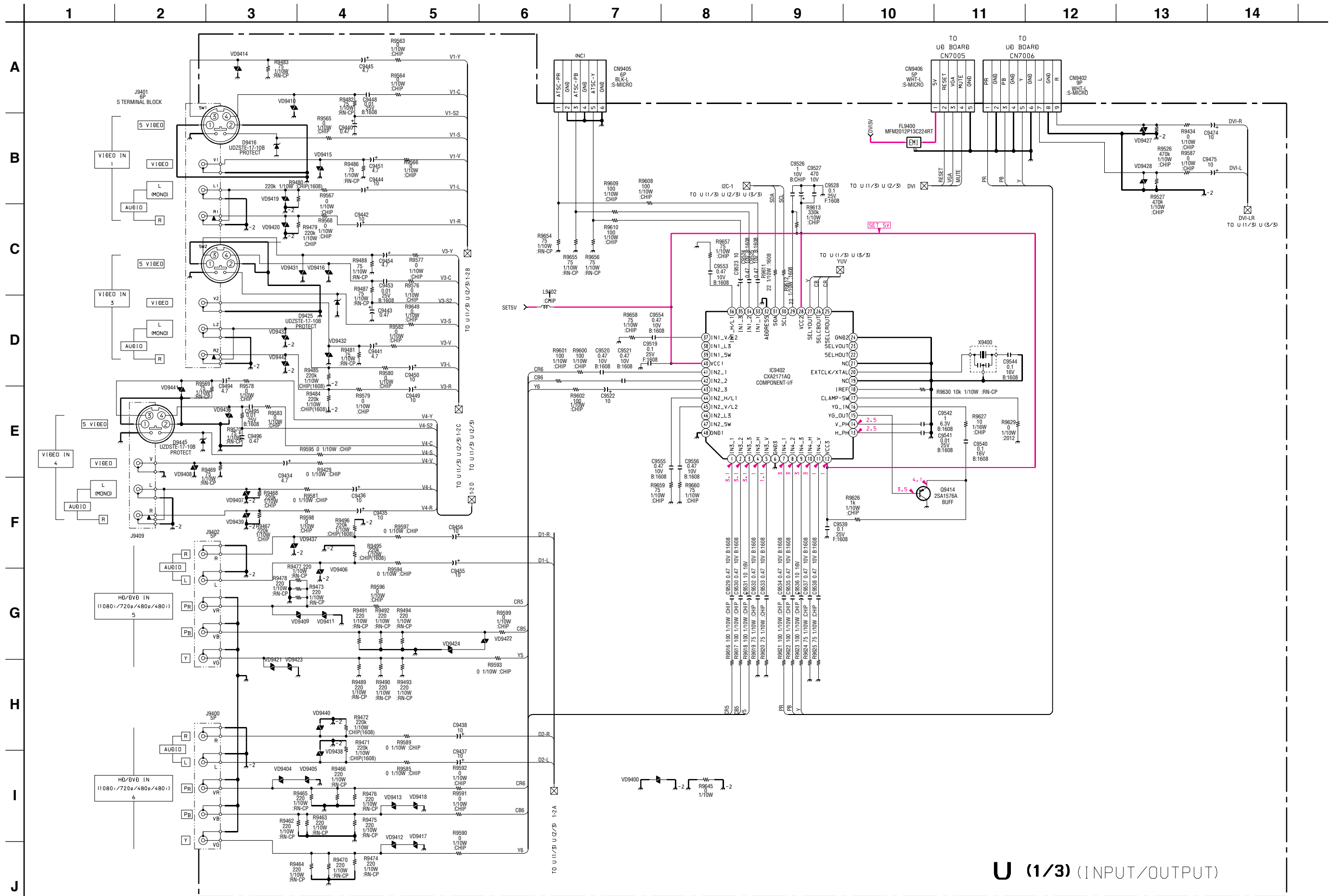

U (1/3) (INPUT/OUTPUT)

(14) Schematic Diagram of U (2/3) Board

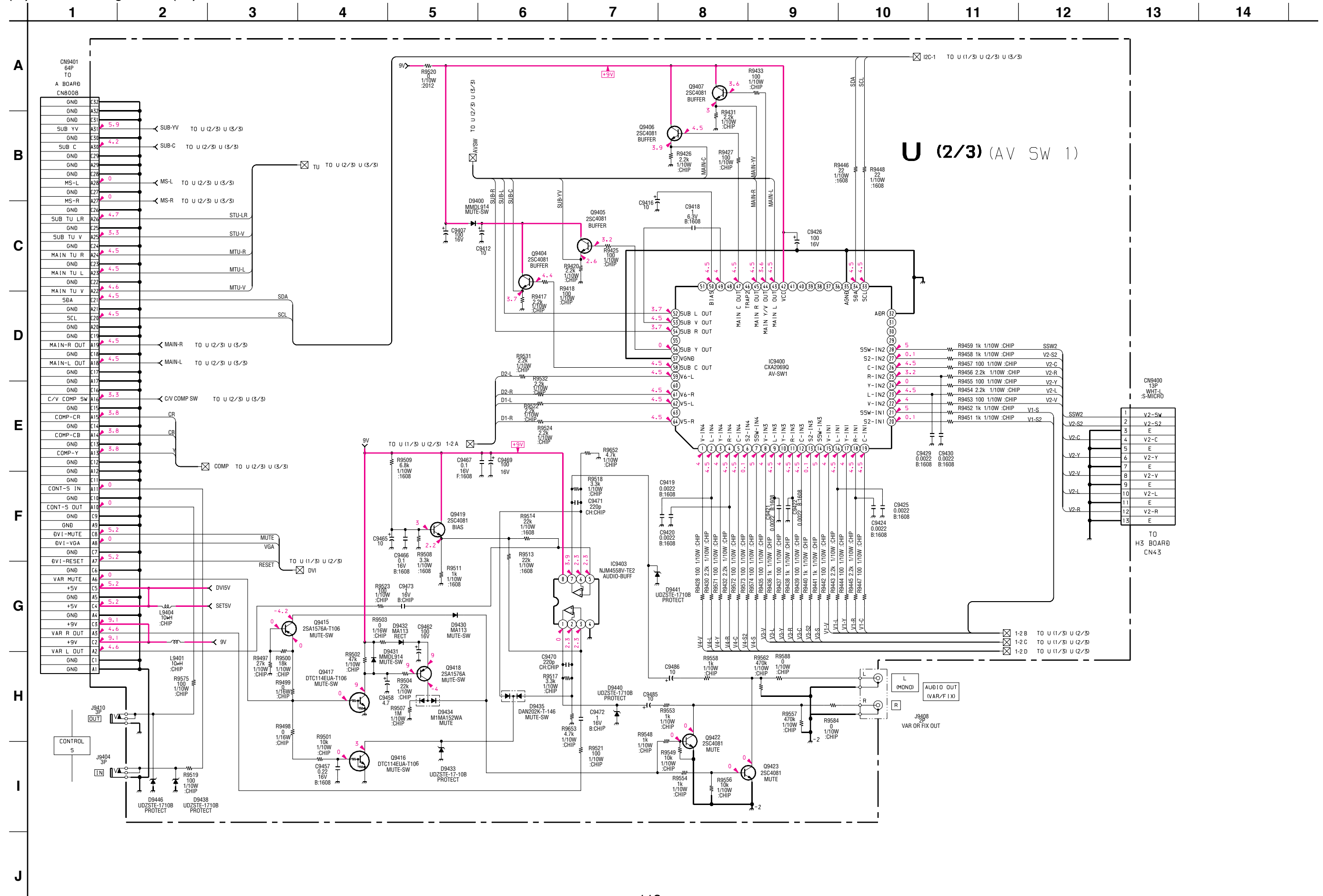

(15) Schematic Diagram of U (3/3) Board

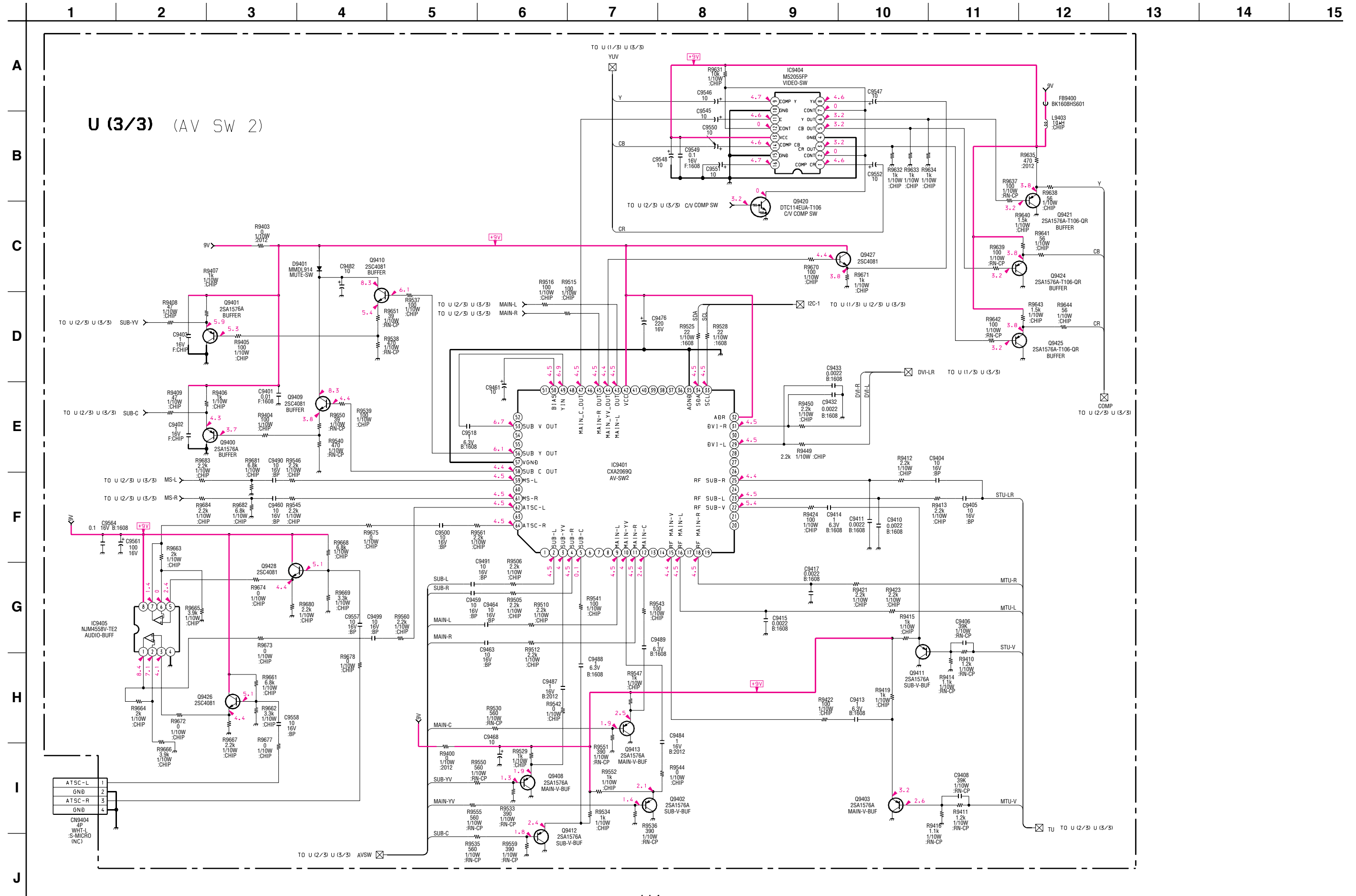

(16) Schematic Diagram of UD (1/2) Board

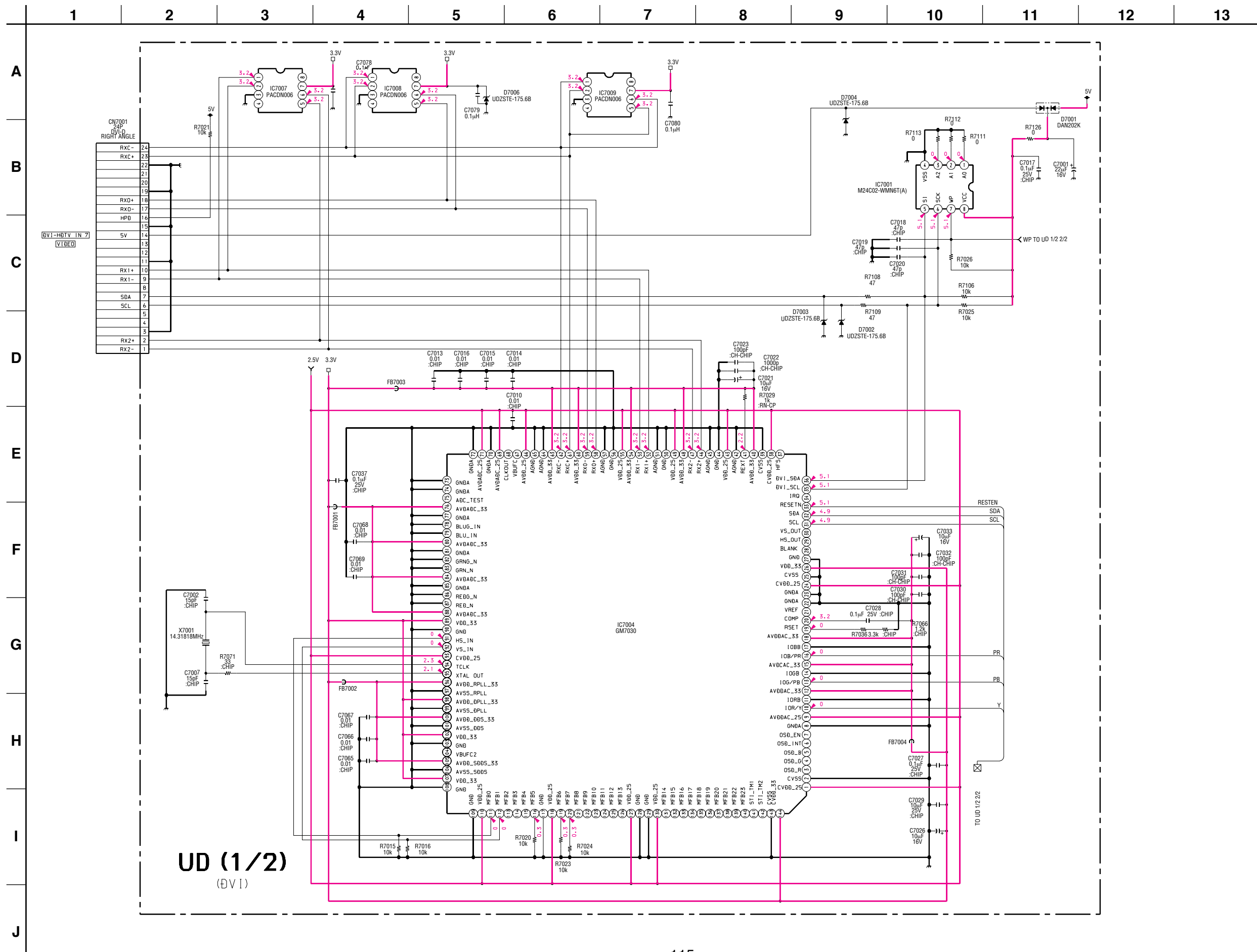

(17) Schematic Diagram of UD (2/2) Board

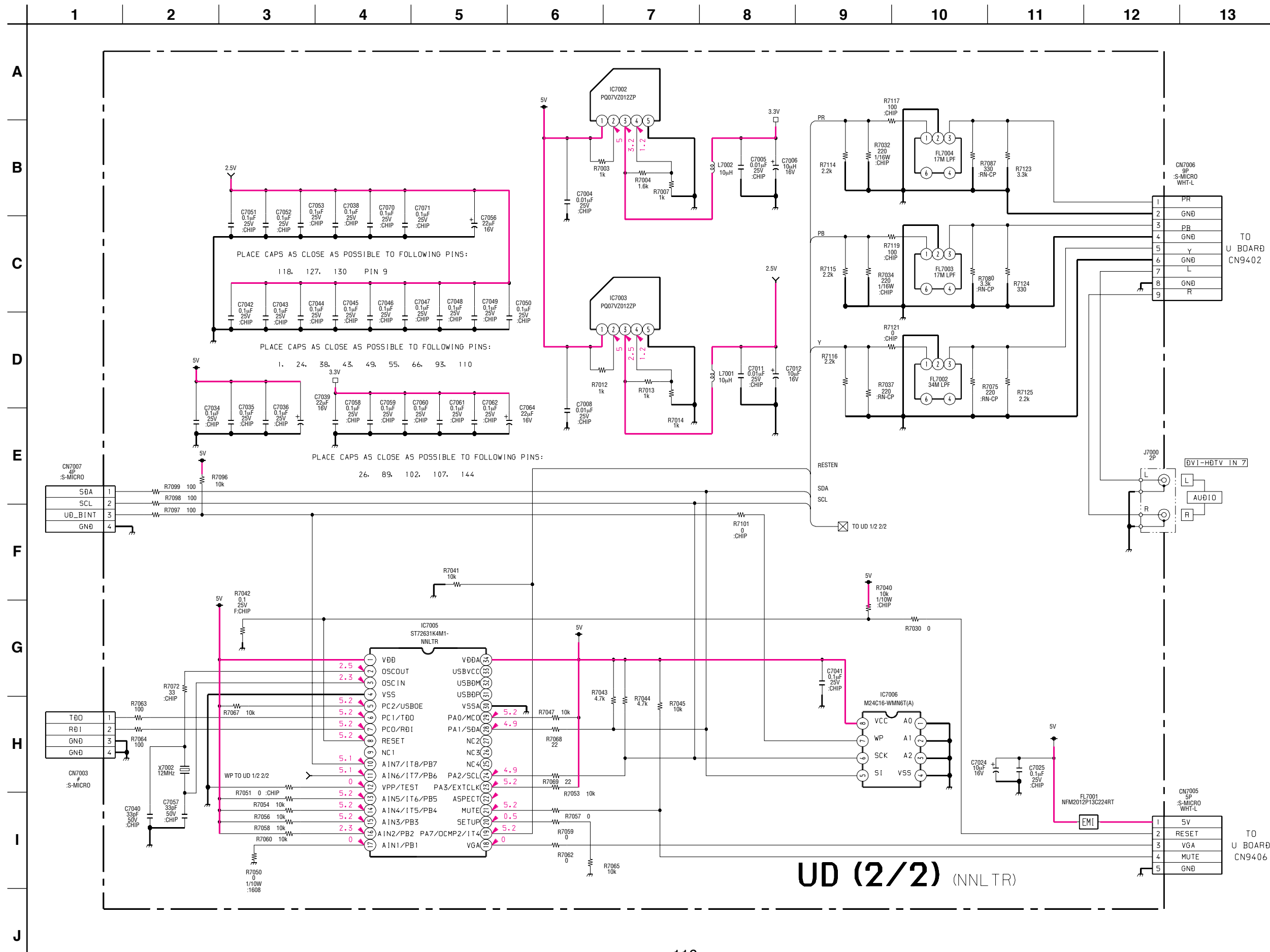

4-5. PRINTED WIRING BOARDS — A BOARD (A Side) —

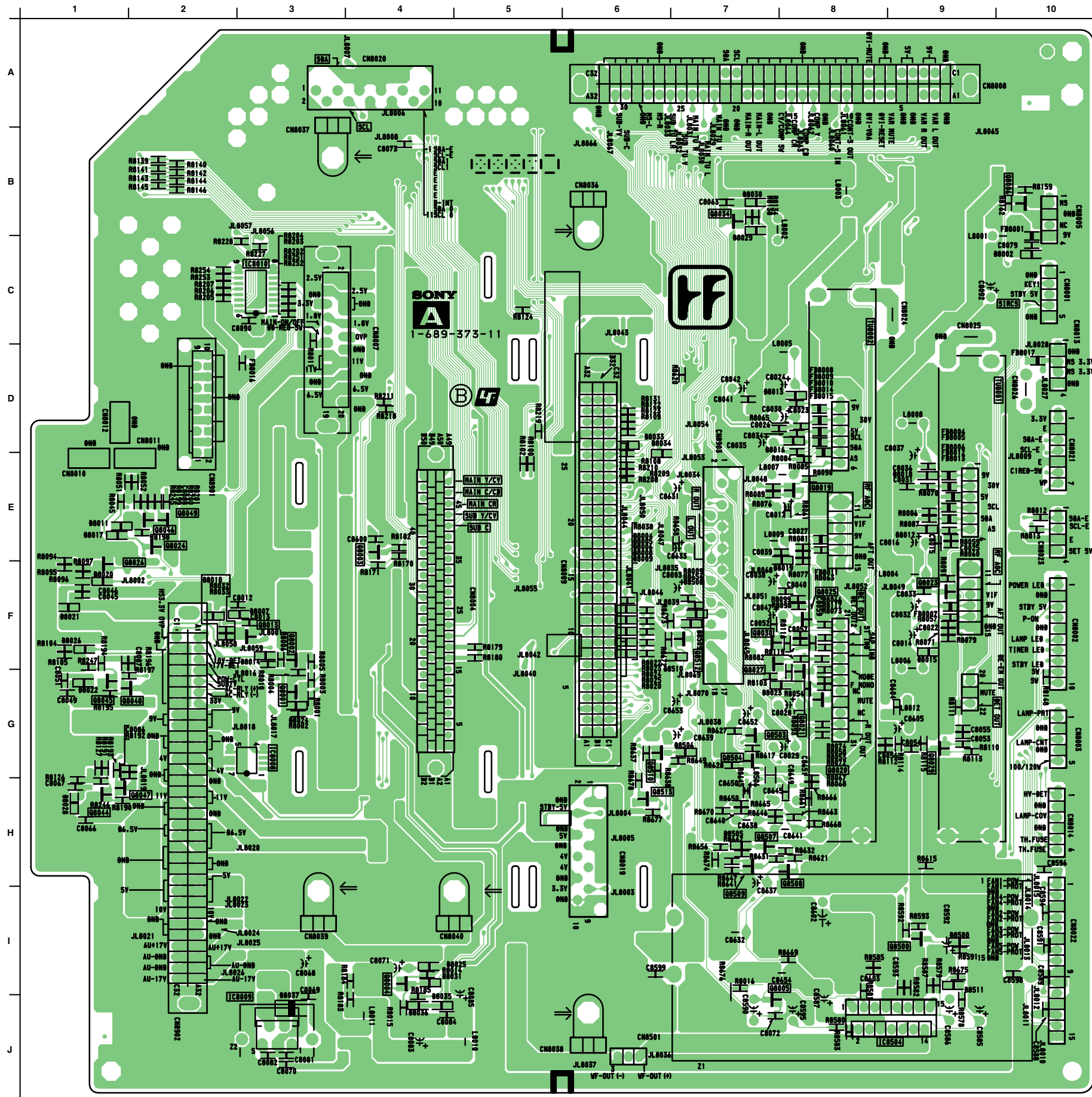

• A BOARD SEMICONDUCTOR LOCATION

IC		DIODE	
Side A	Side B	Side A	Side B
IC8001	B-3	D8001	B-4
IC8003	E-9	D8003	B-3
IC8005	G-10	D8004	F-6
IC8006	H-9	D8005	F-6
IC8007	B-4	D8006	F-6
IC8008	G-3	D8011	E-1
IC8009	J-8	D8014	F-3
IC8010	C-3	D8017	E-1
IC8504	J-8	D8022	G-1
IC8507	G-3	D8023	G-7
TRANSISTOR		D8025	I-4
Side A	Side B	D8026	F-1
Q8001	G-3	D8027	G-9
Q8002	F-3	D8028	H-1
Q8003	E-4	D8029	B-7
Q8004	I-4	D8030	B-7
Q8005	J-7	D8031	I-4
Q8006	B-10	D8033	D-6
Q8008	A-3	D8034	E-6
Q8009	B-2	D8035	J-4
Q8014	B-3	D8036	J-4
Q8015	B-3	D8037	J-3
Q8016	B-3	D8038	B-3
Q8017	B-3	D8500	I-9
Q8018	B-4	D8505	H-7
Q8019	E-8	D8506	G-7
Q8021	G-7	D8508	F-7
Q8022	B-4	D8509	F-7
Q8023	F-9	D8510	F-7
Q8024	E-2	D8511	I-93
Q8025	F-8		
Q8027	F-7		
Q8029	G-9		
Q8030	F-7		
Q8034	B-7		
Q8035	C-3		
Q8036	C-2		
Q8037	B-2		
Q8039	B-3		
Q8041	B-3		
Q8044	H-1		
Q8045	G-1		
Q8046	E-2		
Q8047	H-2		
Q8048	G-2		
Q8049	E-2		
Q8051	A-4		
Q8052	B-4		
Q8500	I-9		
Q8503	G-7		
Q8504	G-7		
Q8507	H-7		
Q8508	H-8		
Q8509	H-7		
Q8510	G-6		
Q8512	F-7		
Q8513	H-6		

*: Refer to Terminal name of semiconductors in silk screen printed circuit (see page 99)

- A BOARD (B Side) -

A [TUNER/RELAY]

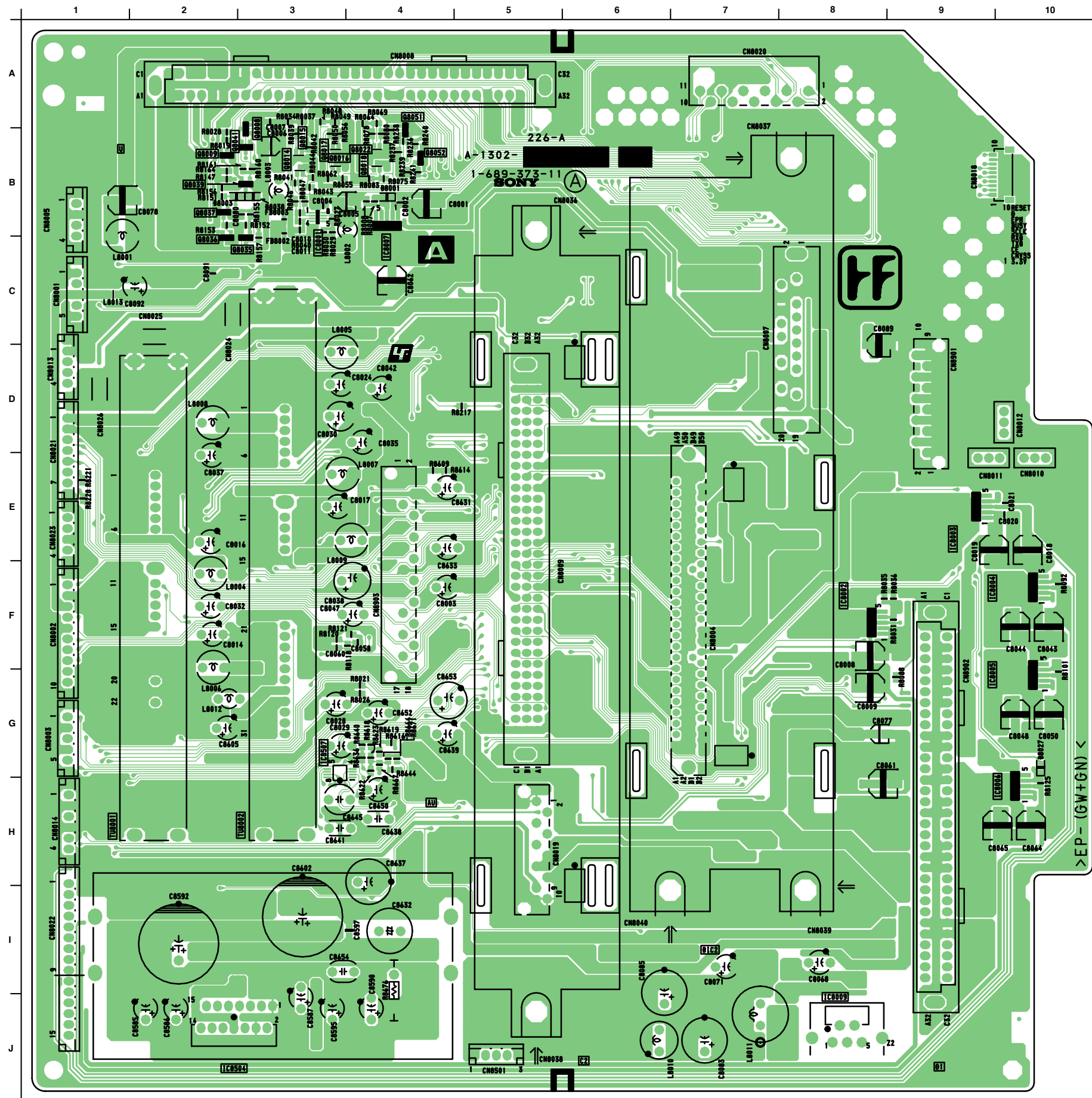



— F BOARD (A Side) —

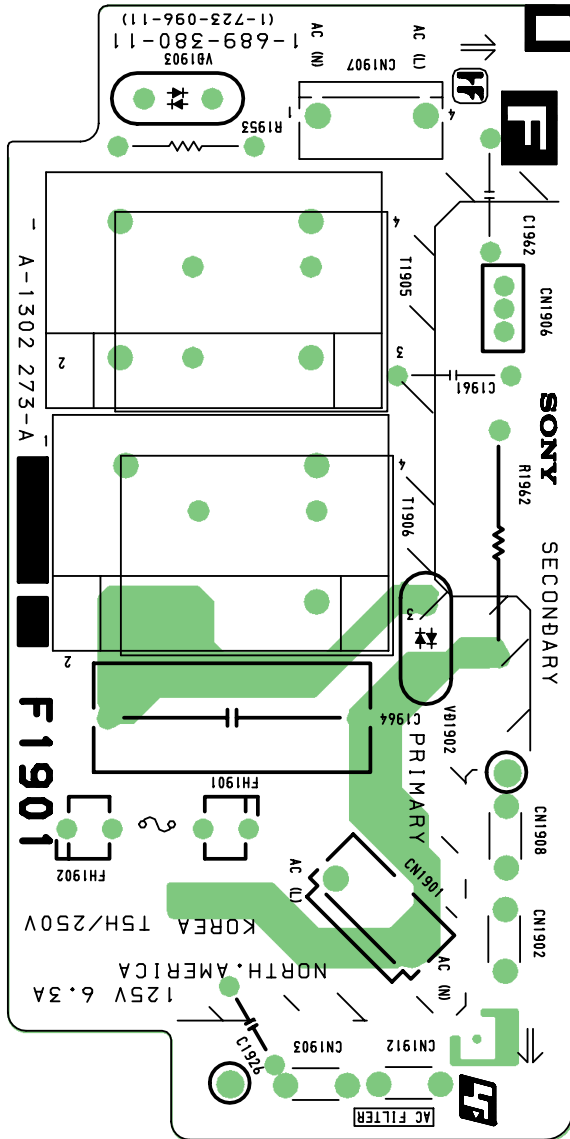

— F BOARD (B Side) —

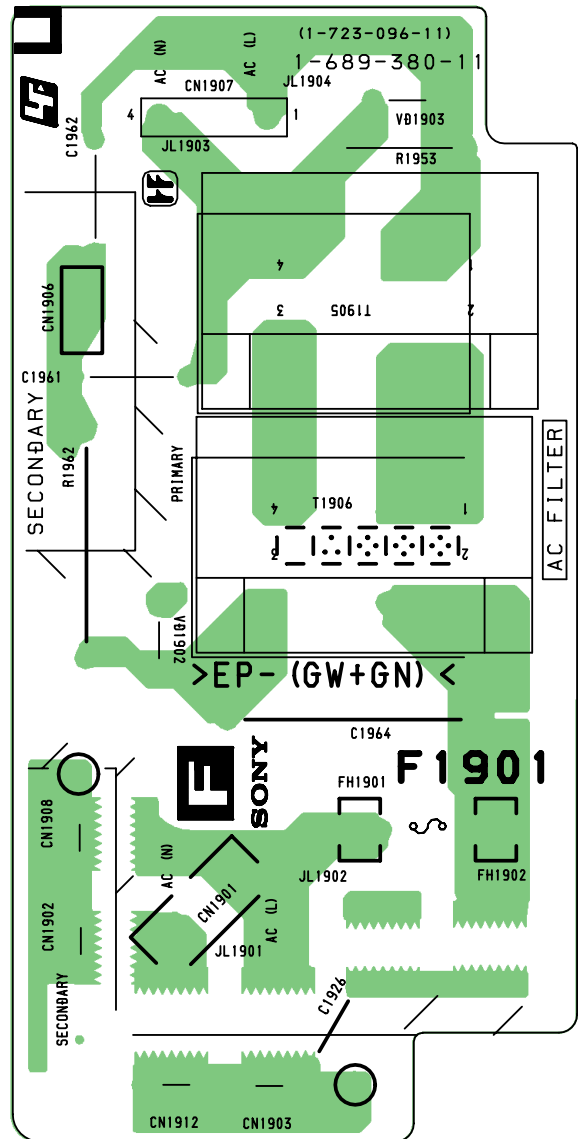

G1 [SWITCH REGULATOR]

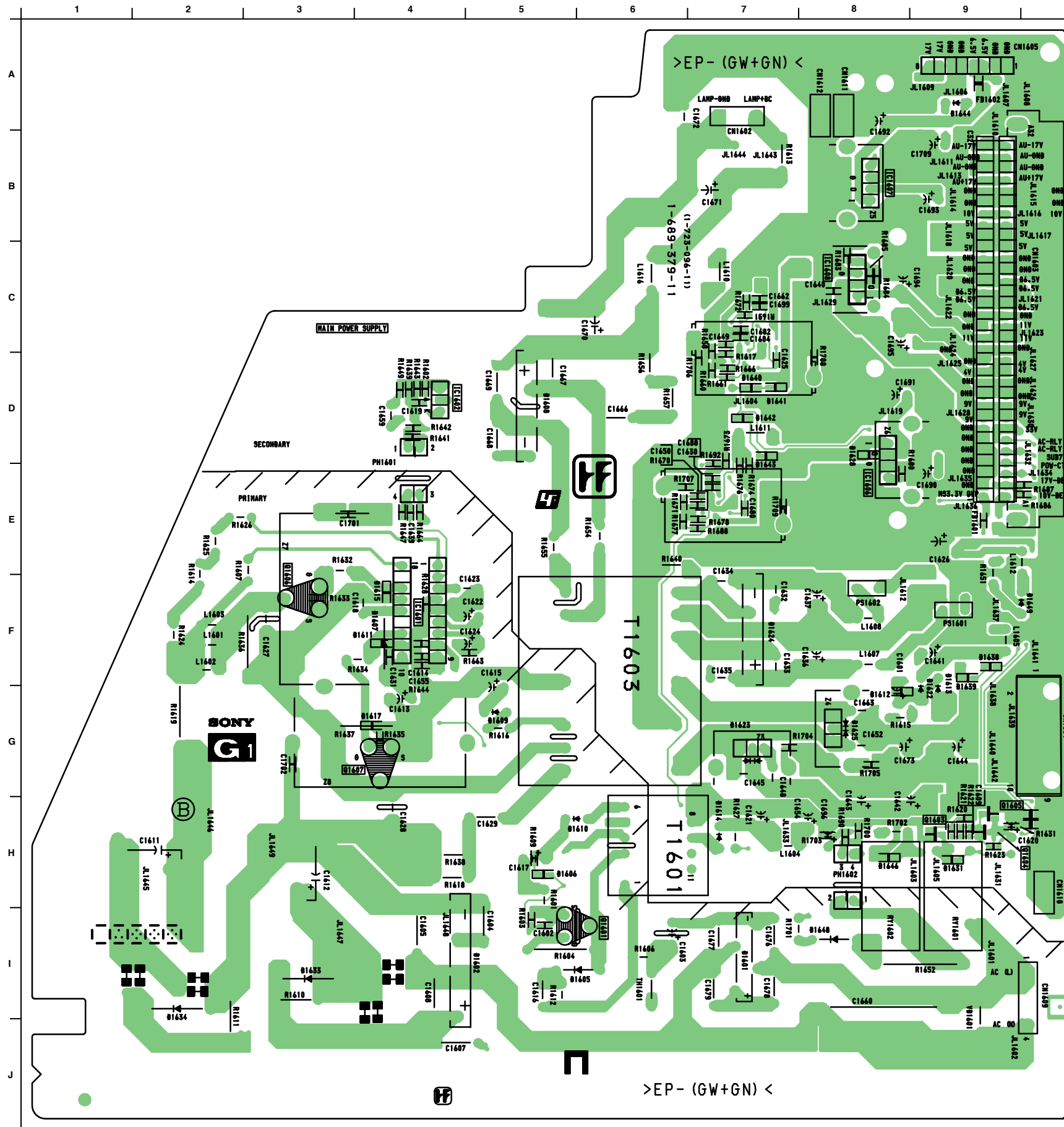

• G1 BOARD SEMICONDUCTOR LOCATION

IC	Side		*
	A	B	
IC1601	F-7	F-4	
IC1602	D-6		
IC1603	D-3		
IC1604	E-4		
IC1606	D-2	D-8	
IC1607	B-2	B-8	
IC1608	C-3	C-8	
TRANSISTOR			
Side			
A	B		*
Q1601	I-5	I-6	
Q1602	I-6		②
Q1603		H-9	①
Q1604		H-9	①
Q1605		H-9	①
Q1606	F-8	F-3	
Q1607	G-7	G-4	
DIODE			
Side			
A	B		*
D1601	I-4	I-7	
D1602	I-6	I-4	
D1603	H-5		③
D1604	H-5		③
D1605	I-5		
D1606		H-5	③
D1607	F-7		
D1608	D-6	D-5	
D1609	G-6	G-5	
D1610	H-5	H-6	
D1612		G-8	③
D1613	G-2		
D1614	H-4	H-7	
D1618	G-1		③
D1619	G-1		③
D1620	C-3		
D1621	E-3		
D1622	G-2		
D1623	G-3	G-7	
D1624	F-4	F-7	
D1625	G-3	G-8	
D1626	C-3		③
D1628		D-8	③
D1629	H-5		③
D1630	H-5		③
D1631		H-9	③
D1632	D-2		
D1633	I-8	I-3	
D1634	I-9	I-2	
D1635	B-3		③
D1636	C-3		③
D1637	C-3		③
D1638		F-9	③
D1639		F-9	③
D1640		D-7	③
D1641		D-7	③
D1642		D-7	③
D1643		D-7	③
D1644	A-2	A-9	
D1645	E-4		③
D1646		H-8	③
D1647	H-2		③
D1648	I-3		
D1649	F-1		

*: Refer to Terminal name of semiconductors in silk screen printed circuit (see page 99)

- G1 BOARD (B Side) -

G1 [SWITCH REGULATOR]

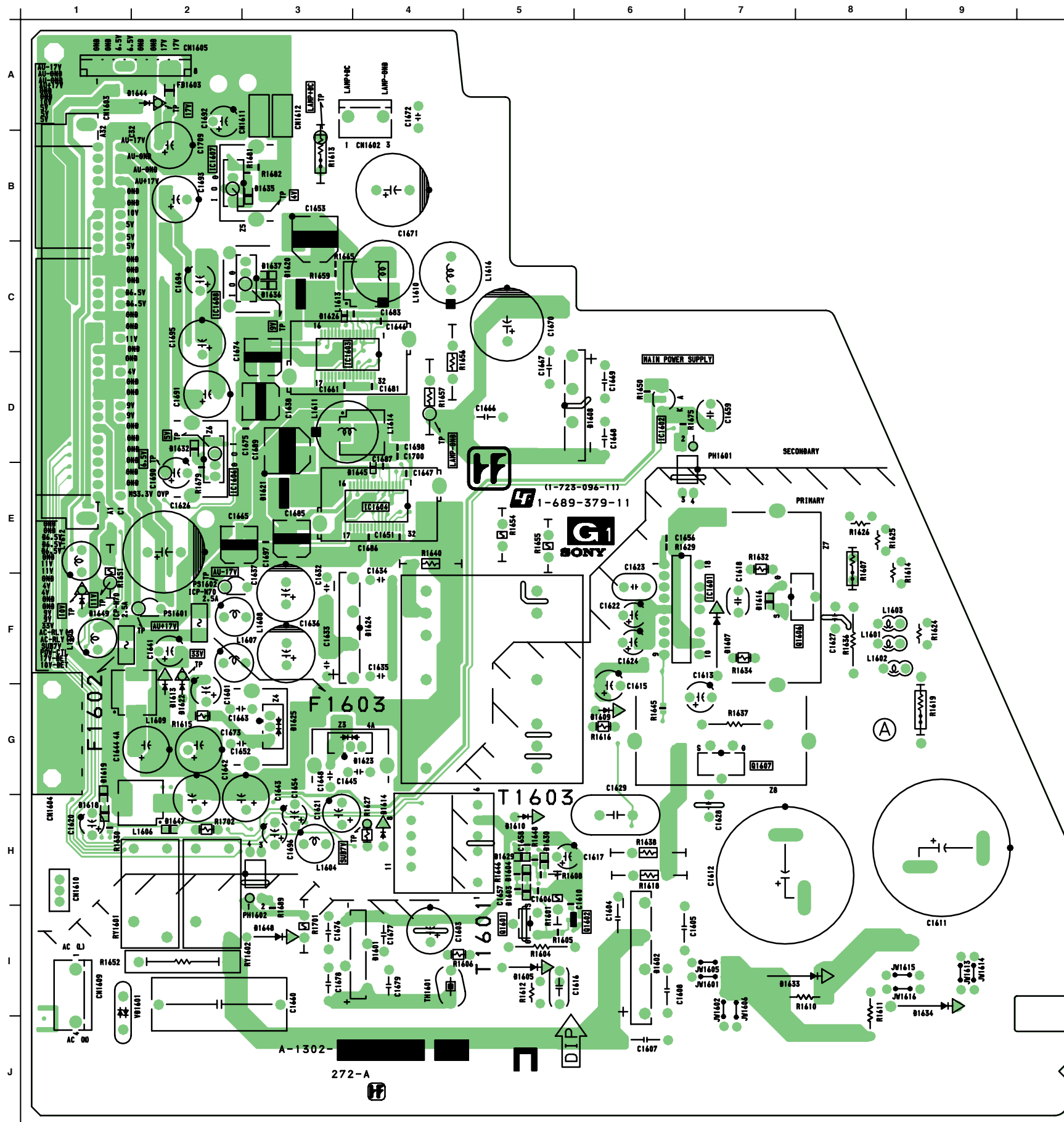

H1 [KEY INPUT, SIRCS]

— H1 BOARD (A Side) —

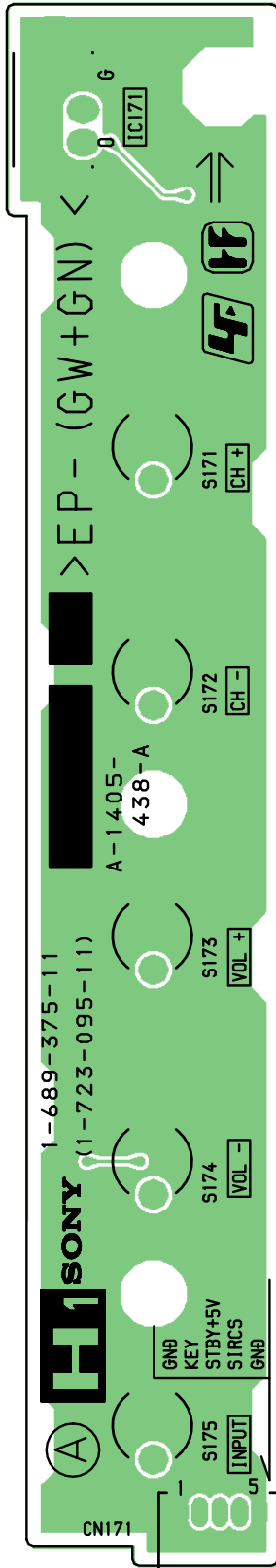

— H1 BOARD (B Side) —

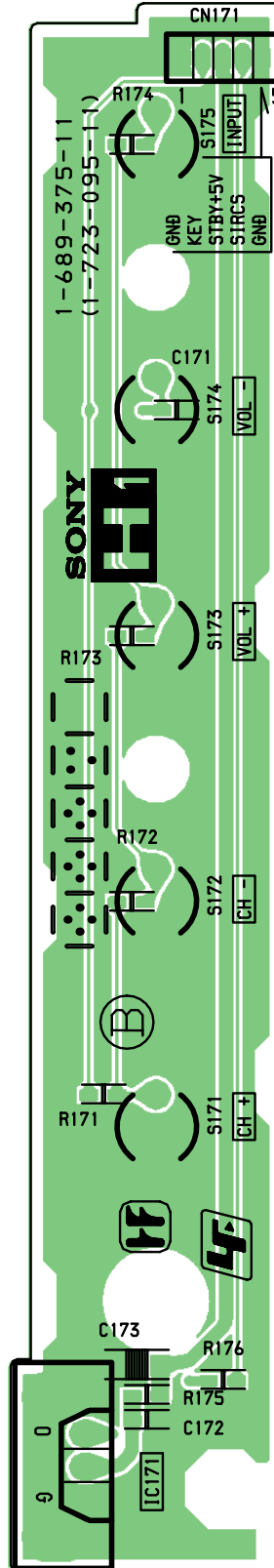

H2 [POWER SWITCH]

— H2 BOARD (A Side) —

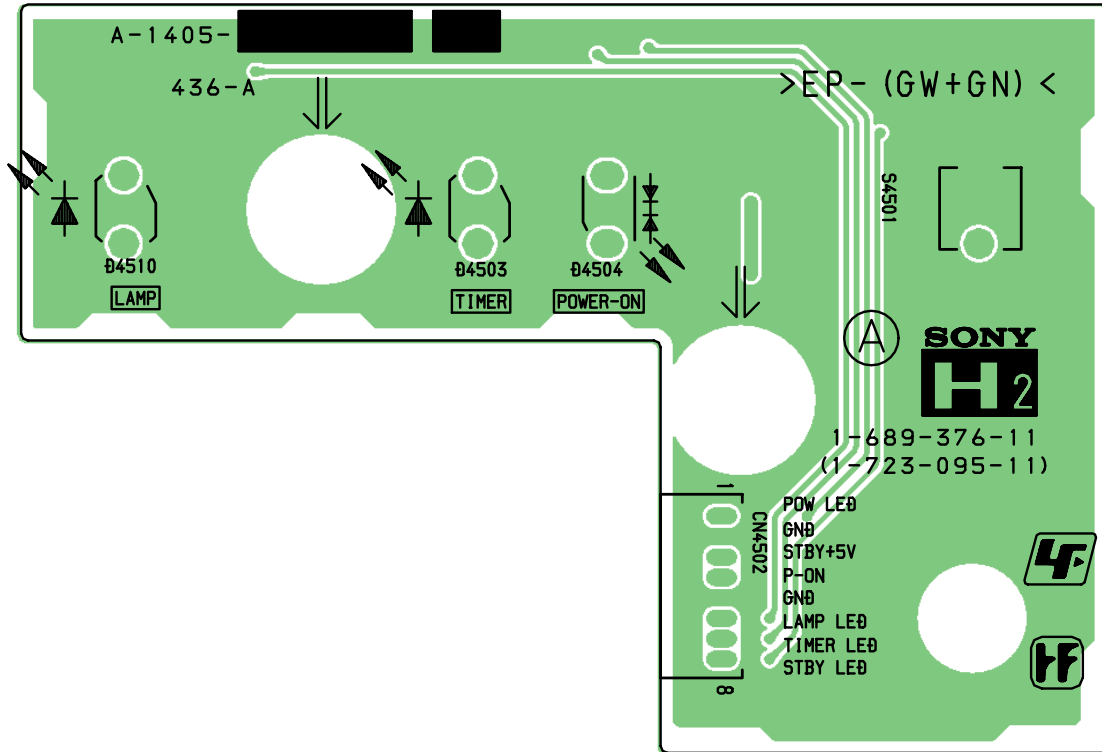

— H2 BOARD (B Side) —

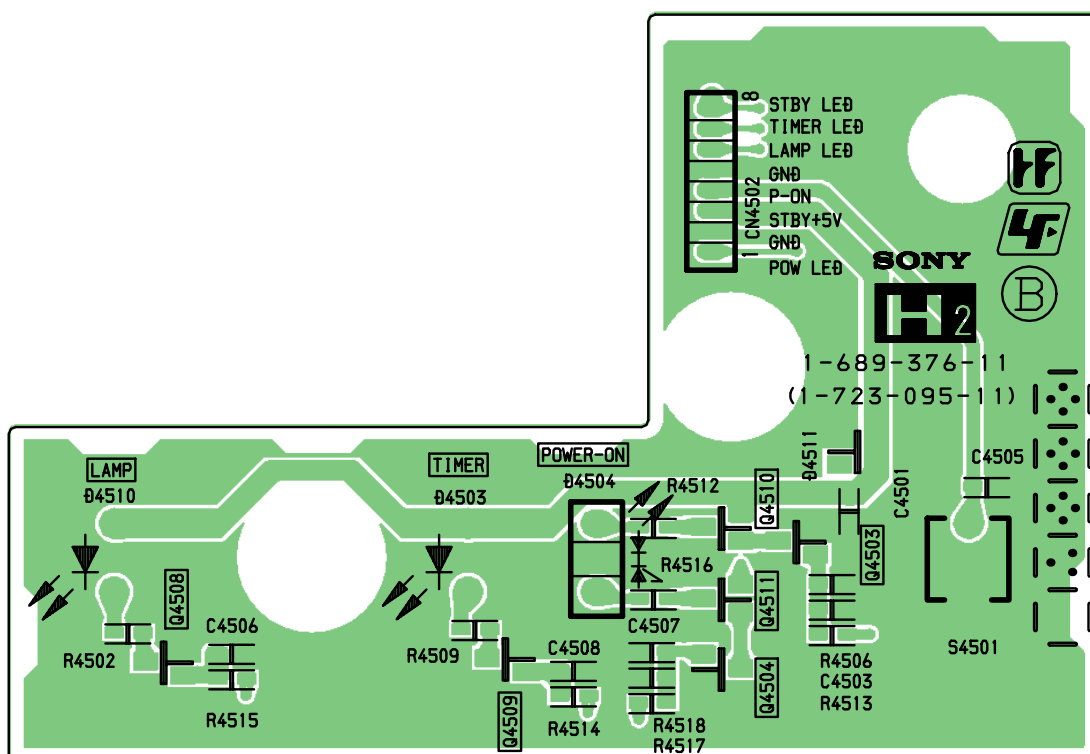

H3 [VIDEO 2 INPUT]

— H3 BOARD (A Side) —

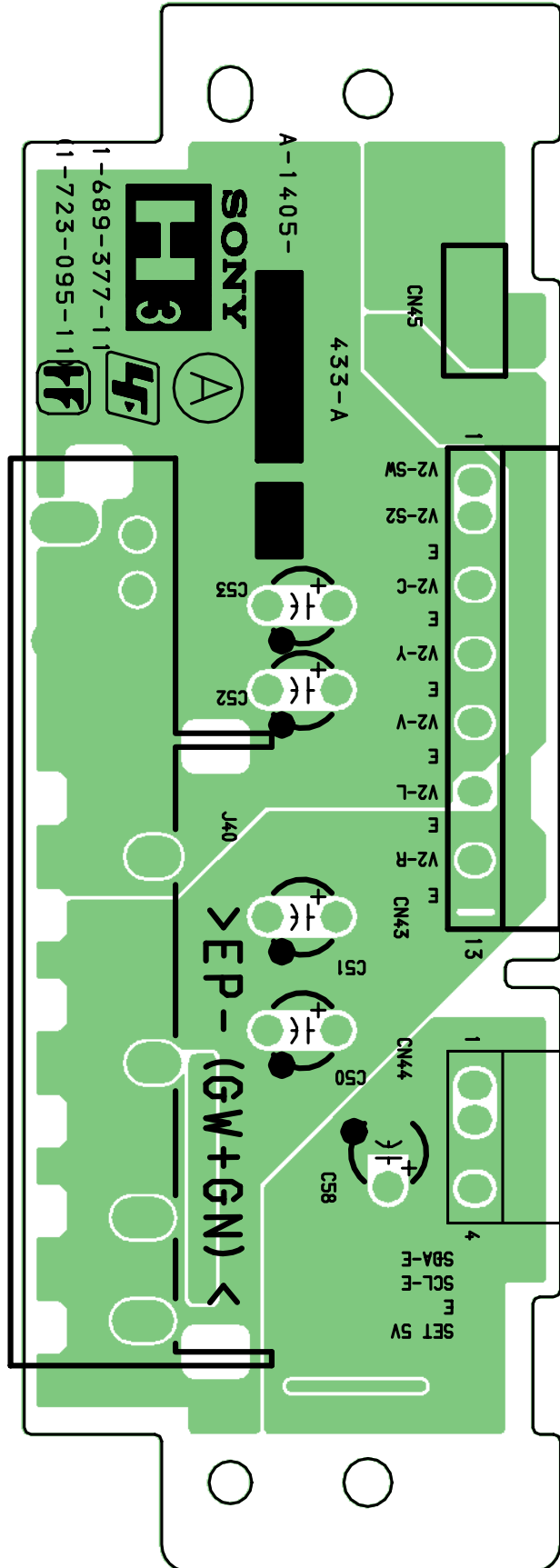

— H3 BOARD (B Side) —

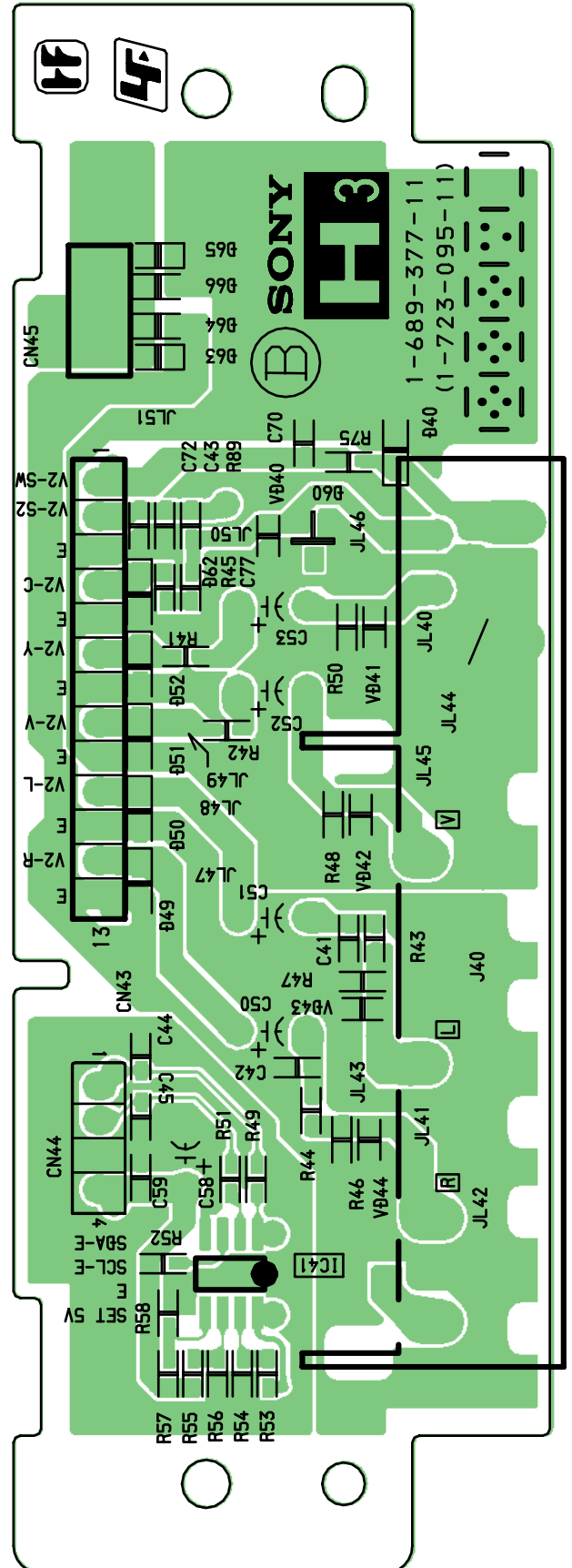



[MEMORY STICK]

- HM BOARD (A Side) -

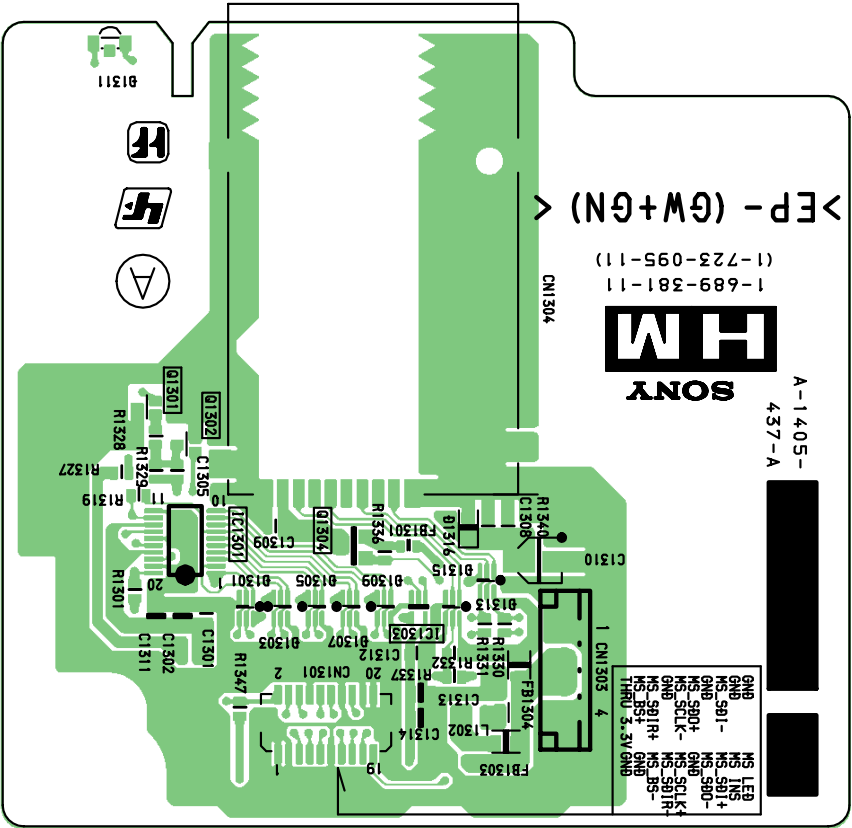

- HM BOARD (B Side) -

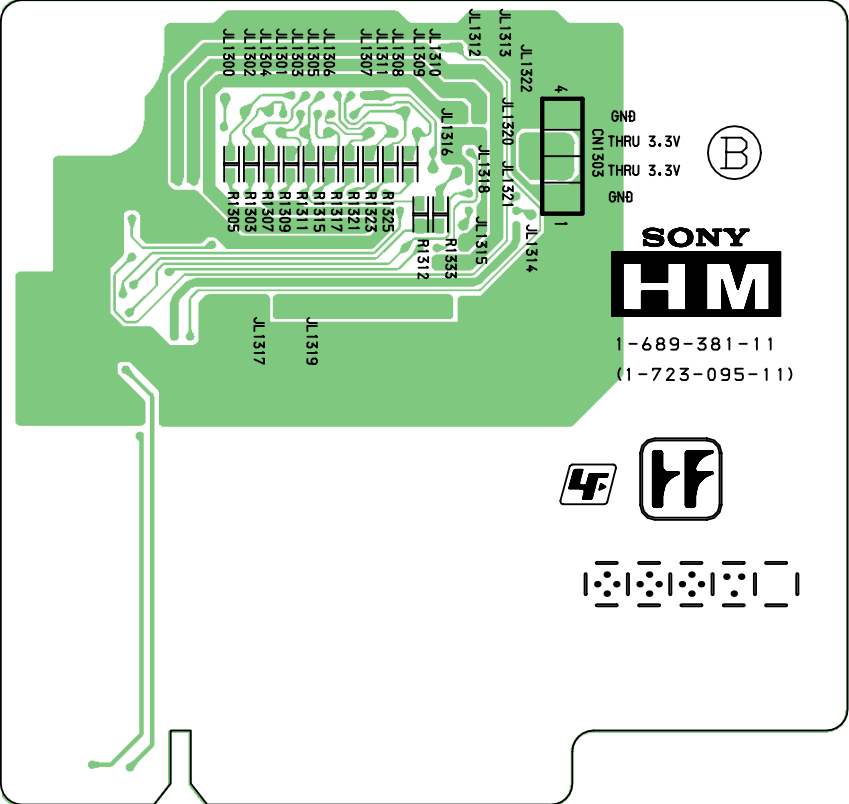

T [LAMP DOOR SWITCH]

— T BOARD (A Side) —

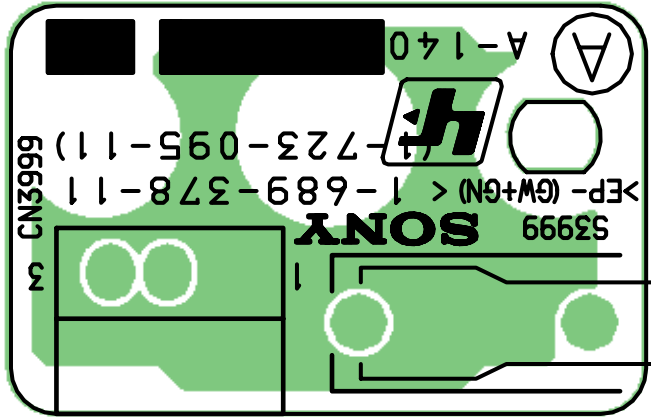

— T BOARD (B Side) —

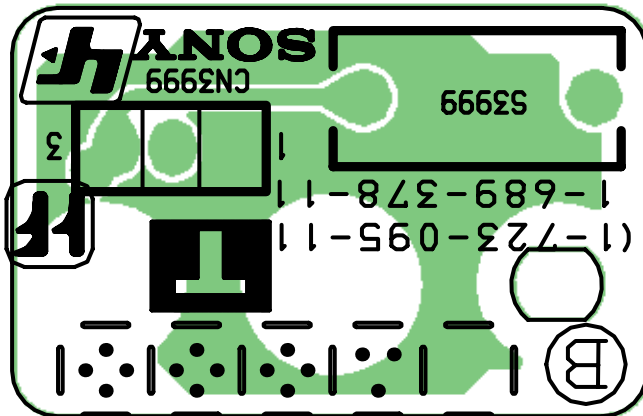

- U BOARD (A Side) -

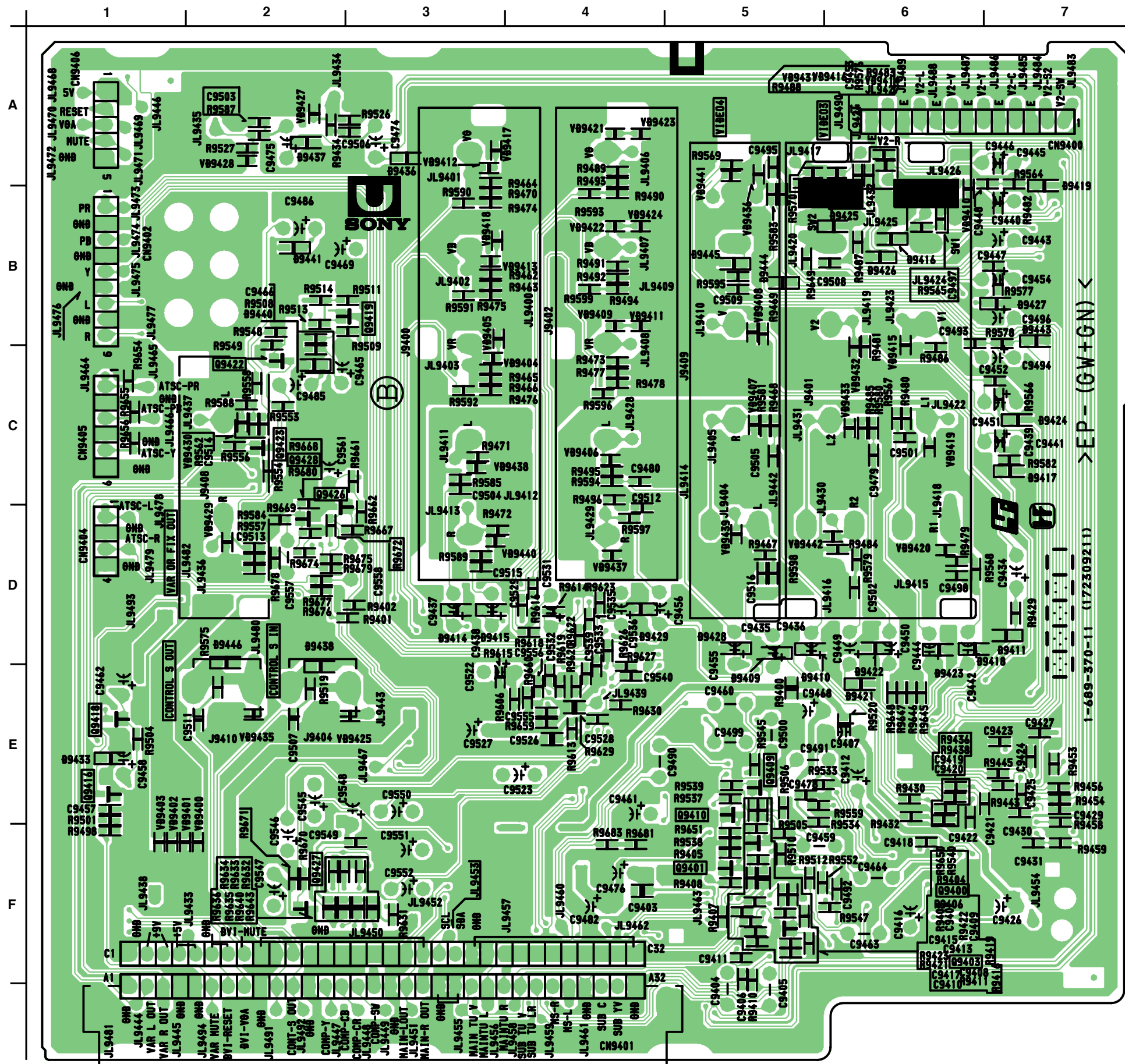

U BOARD SEMICONDUCTOR LOCATION

IC		Side A	Side B	*
IC9400	E-1			
IC9401	F-3			
IC9402	E-4			
IC9403	B-6			
IC9404	F-5			
IC9405	D-6			
TRANSISTOR				
		Side A	Side B	*
Q9400			F-5	①
Q9401			F-5	①
Q9402	F-2			②
Q9403			F-5	①
Q9404	E-2			②
Q9405	F-2			②
Q9406	F-2			②
Q9407	F-2			②
Q9408	E-3			②
Q9409			E-5	①
Q9410			E-5	①
Q9411			F-3	①
Q9412	E-3			②
Q9413	F-3			②
Q9414	D-2			②
Q9415	E-7			②
Q9416			E-1	①
Q9417	E-5			②
Q9418			E-1	①
Q9419			B-3	①
Q9420	F-5			②
Q9421	F-6			②
Q9422			C-2	①
Q9423			C-2	①
Q9424	F-6			②
Q9425	F-5			②
Q9426			C-2	①
Q9427			F-2	①
Q9428			C-2	①
DIODE				
		Side A	Side B	*
D9400	E-2			③
D9401	F-4			③
D9416			B-6	③
D9425			B-6	③
D9430	E-5			③
D9431	E-5			③
D9432	D-7			③
D9433			E-1	③
D9434	E-7			③
D9435	B-6			③
D9438			E-2	③
D9440			C-2	③
D9441			B-2	③
D9445			B-5	③
D9446			D-2	③

*: Refer to Terminal name of semiconductors in silk screen printed circuit (see page 99)

- U BOARD (B Side) -

U [VIDEO INPUT]

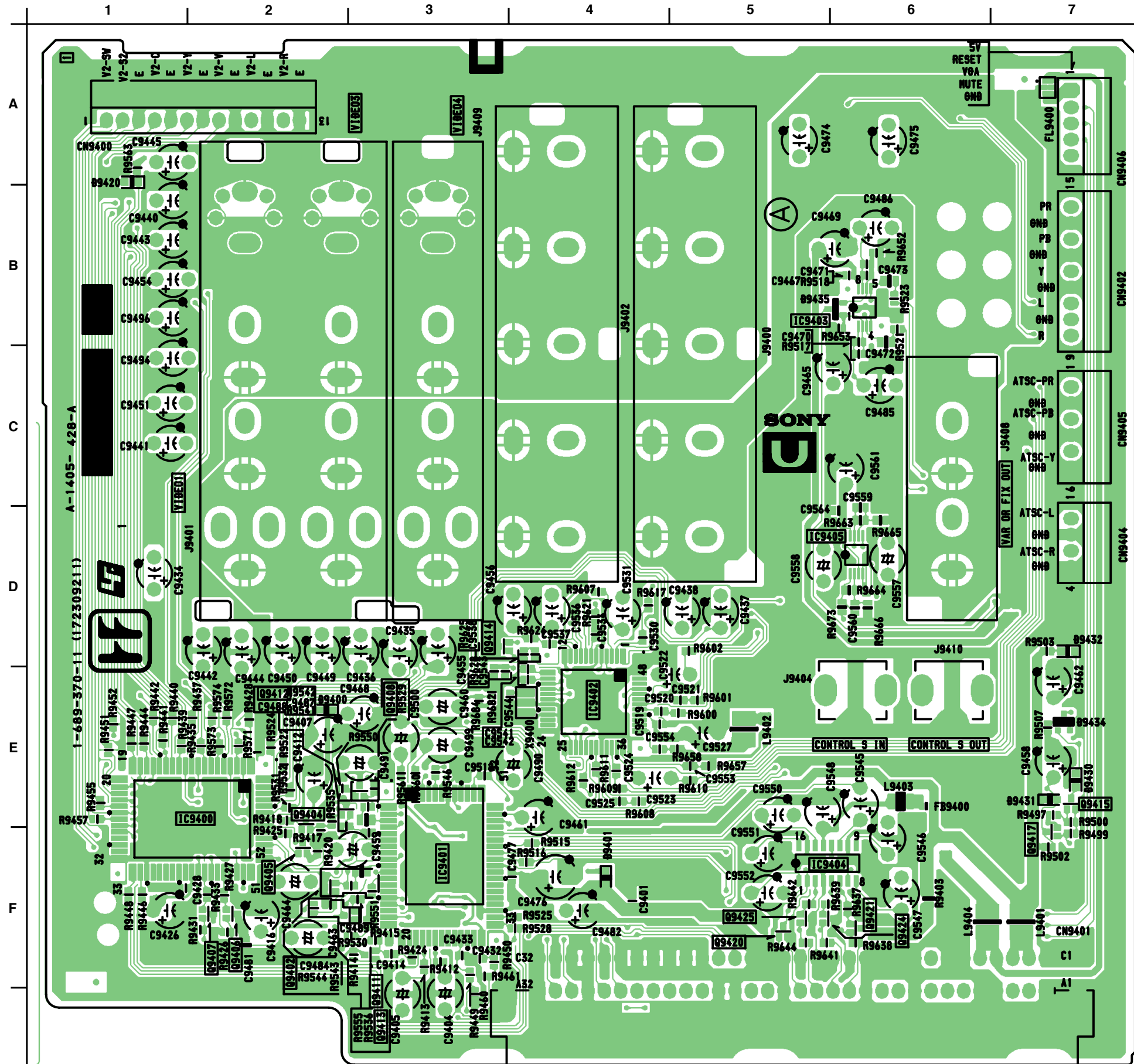

— UD BOARD —

UD [DVI IN]

• U BOARD SEMICONDUCTOR LOCATION

IC			
	Side A	Side B	*
IC7001	C-4		
IC7002	A-5		
IC7003	A-4		
IC7004	B-2		
IC7005	B-5		
IC7006	B-4		
IC7007	C-2		
IC7008	C-3		
IC7009	C-3		
DIODE			
	Side A	Side B	*
D7001	C-4		⑨
D7002		C-3	⑩
D7003		C-3	⑪
D7004	C-4		⑫
D7006		C-4	⑬

*: Refer to Terminal name of semiconductors in silk screen printed circuit (see page 99)

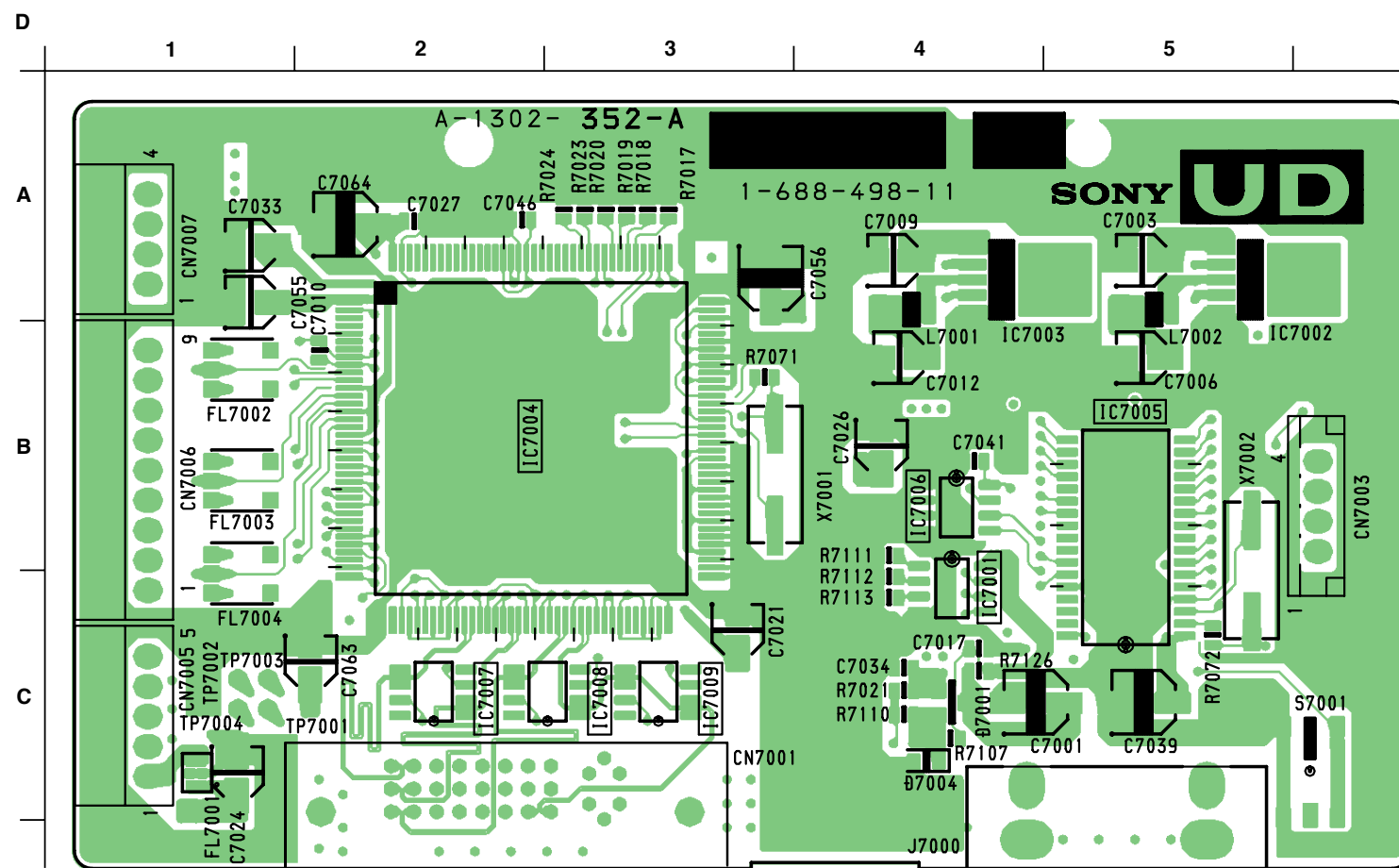
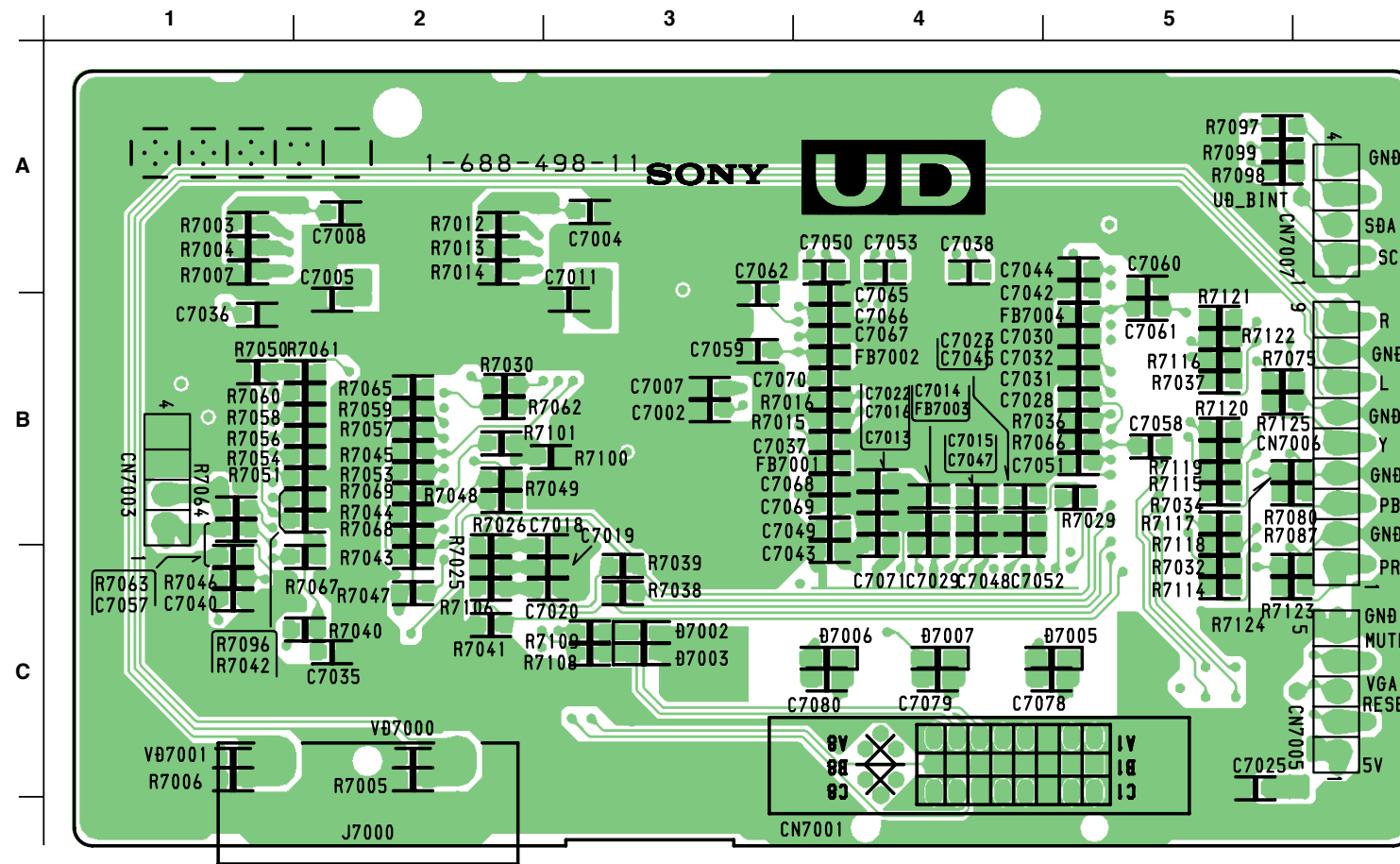

4-6. IC BLOCK DIAGRAMS

• U (1/3) BOARD IC9402
CXA2171AQ

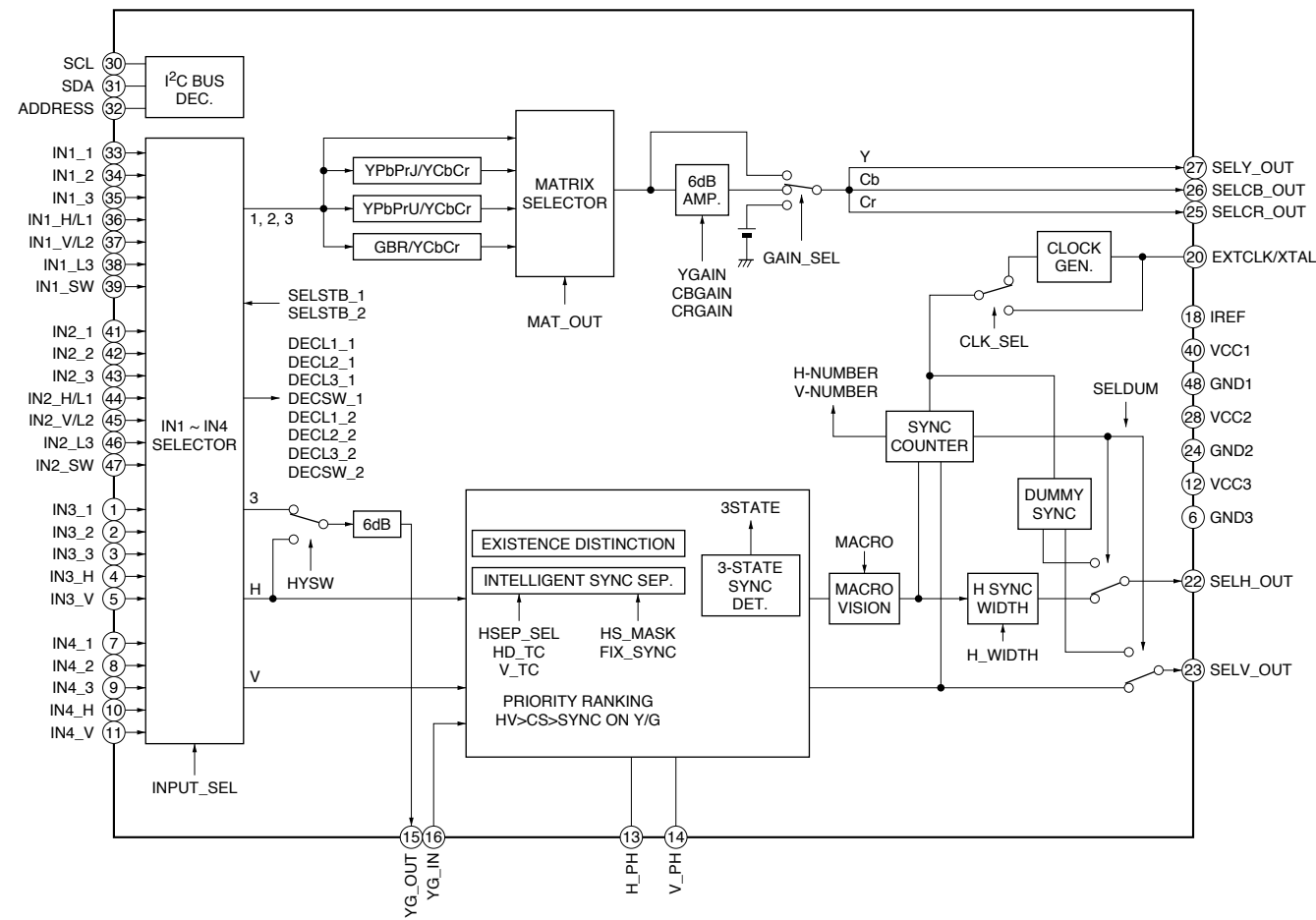

• U (2/3) BOARD IC9400
• U (3/3) BOARD IC9401
CXA2069Q

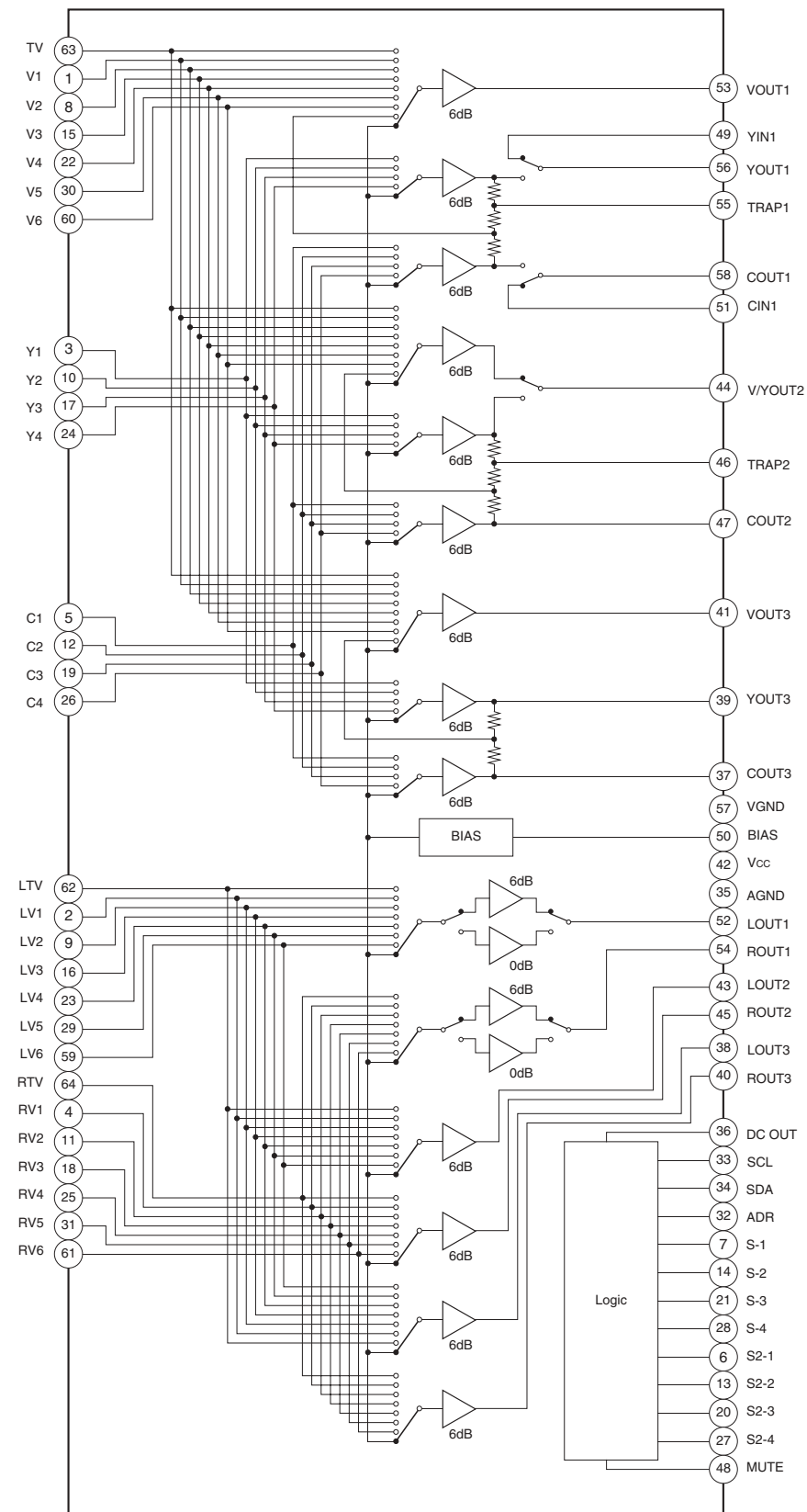

4-7. SEMICONDUCTORS

CXA1875AM-T4 C1S
SN65LVDT14PWR C1S

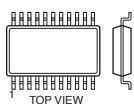

16Pin

CXA2069Q
NJW1149

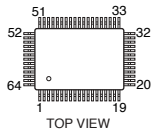

CXA2171AQ-T6

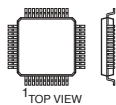

48Pin

LM75CIMX-5
M24C02-WMN6T(A)
M24C16-WMN6T(A)
MAX4451EKA-TG069
NJM4558V-TE2

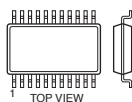

8Pin

M52055FP

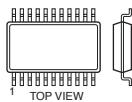

14Pin

MCZ3001DA

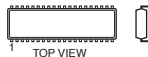

18Pin

NJM78M12DL1A-TE2

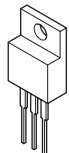

NJM79M12DL1A-TE1

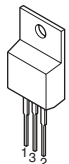

PQ07VZ012ZP

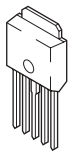

PQ30RV11
PQ30RV21
PQ30RV31

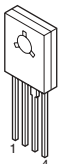

SN74CBTLV1G125DCKR

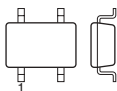

5Pin

TDA7265

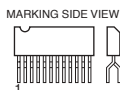

11Pin

TDA7296

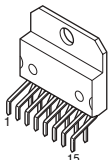

UPC1093J-1-T

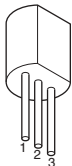

2SA1162-G
2SA1576A-T106-R
2SA1611-M5M6
2SC1623-L5L6
2SC4081-R
2SD601A-Q
DTA114EKA-T146
DTC114EK
DTC114EU
DTC143EKA-T146
DTC144EKA
DTC144EUA-T146

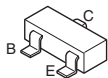

2SK2663

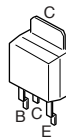

D10SC6M

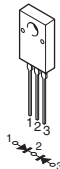

D1N20R
D1NS4
RD12SB2
RD18SB2
RD3.3SB2

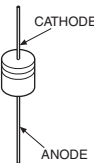

D1NL20J-TR

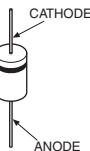

D2SB60A-F04
D4SBL40
D4SBS6-F
D6SB60L

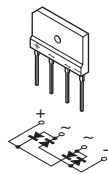

DAP202K
M1MA152WK-T1

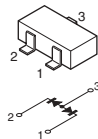

DE5SC3ML

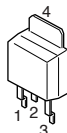

DTZ10B
HZU11B1TRF
MA111-TX
MA113-(TX)
UDZS-TE17-5.6B
UDZ-TE-17-4.3B
UDZ-TE-17-8.2B

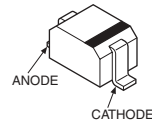

ERA22-08
ERC04-06SE

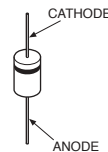

RD5.6SB2-T1
RD6.2SB2-T1
RD7.5SB2-T1

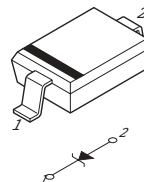

SLR-325VCT31

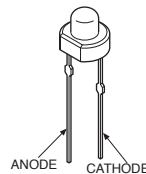

MEMO

A series of horizontal dashed lines for writing.

SECTION 5

EXPLODED VIEWS

NOTE:

- Items with no part number and no description are not stocked because they are seldom required for routine service
- The construction parts of an assembled part are indicated with a collation number in the remark column.
- Items marked " * " are not stocked since they are seldom required for routine service. Some delay should be anticipated when ordering these items.

The components identified by shading and mark Δ are critical for safety. Replace only with part number specified.

Les composants identifiés par une trame et une marque Δ sont critiques pour la sécurité. Ne les remplacer que par une pièce portant le numéro spécifié.

1. KF-42WE610/50WE610 SCREEN MIRROR BLOCK, COVERS

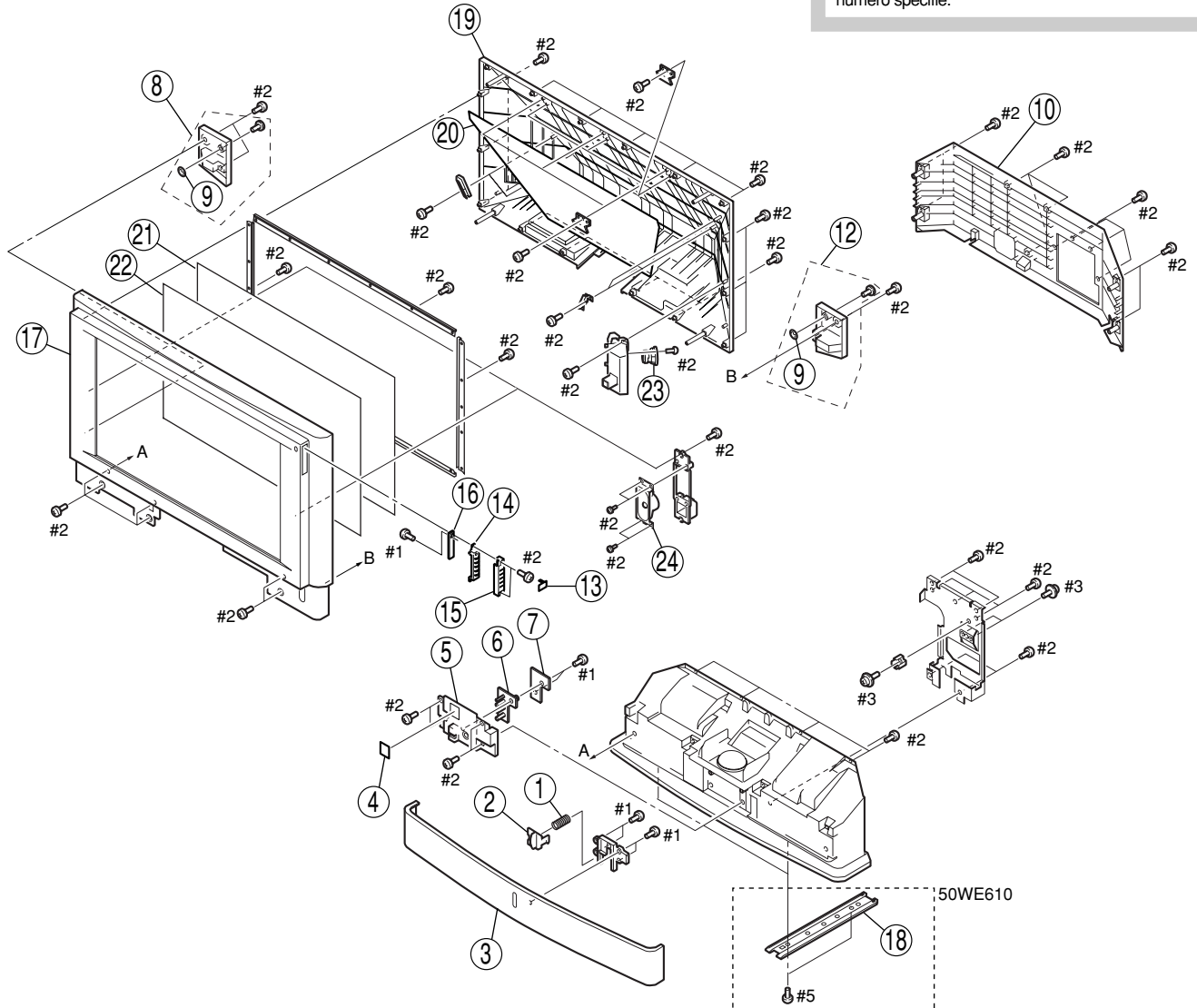

REF. NO.	PART NO.	DESCRIPTION	REMARK	REF. NO.	PART NO.	DESCRIPTION	REMARK
1	4-036-405-01	SPRING, COMPRESSION		16	* A-1405-438-B	H1 BOARD, COMPLETE	
2	4-094-706-01	BUTTON, POWER		17	A-1087-013-A	SCREEN FRAME ASSY(IRP) (42WE610)	
3	X-4041-688-1	FRONT COVER ASSY	(42WE610)	17	A-1087-016-A	SCREEN FRAME ASSY(IRP) (50WE610)	
3	X-4042-017-1	COVER ASSY (50), FRONT	(50WE610)	18	X-4042-014-2	PLATE (50) ASSY, FOOT	(50WE610)
4	4-097-613-01	SHEET, H2		19	A-1087-014-A	MIRROR COVER ASSY(IRP) (42WE610)	
5	4-094-719-01	BRACKET, H2	(42WE610)	19	A-1087-017-A	MIRROR COVER ASSY(IRP) (50WE610)	
5	4-095-607-01	BRACKET, H2	(50WE610)	20	A-1087-015-A	MIRROR (42) ASSY(IRP)	(42WE610)
6	4-094-707-01	GUIDE (LED), LIGHT		20	A-1087-018-A	MIRROR (50) ASSY(IRP)	(50WE610)
7	* A-1405-436-A	H2 BOARD, COMPLETE		21	4-097-030-11	PLATE (42F), DIFFUSION	(42WE610)
8	X-4042-010-1	CAP (L) ASSY, REAR	(42WE610)	21	4-097-032-11	PLATE (50F), DIFFUSION	(50WE610)
8	X-4042-019-1	CAP (L) ASSY, REAR	(50WE610)	22	4-097-031-11	PLATE (42L), DIFFUSION	(42WE610)
9	* 3-650-537-00	WASHER		22	4-097-033-11	PLATE (50L), DIFFUSION	(50WE610)
10	4-094-695-01	COVER, REAR	(42WE610)	23	1-825-586-12	LOUD SPEAKER (10cm)	
10	4-094-695-11	COVER, REAR	(50WE610)	24	1-825-585-12	LOUD SPEAKER (13X7cm)	
12	X-4042-009-1	CAP (R) ASSY, REAR	(42WE610)				
12	X-4042-018-1	CAP (R) ASSY, REAR	(50WE610)	#1	7-685-648-79	SCREW +BVTP 3X12 TYPE2 IT-3	
13	4-094-713-01	CAP, H1 BRACKET		#2	7-685-663-79	SCREW +BVTP 4X16 TYPE2 IT-3	
14	4-094-711-02	BRACKET, H1		#3	7-682-948-01	SCREW +PSW 3X8	
15	4-094-712-01	BUTTON, H1		#5	7-685-661-71	SCREW +BVTP 4X12 TYPE2 IT-3(50WE610)	

2. KF-60WE610 SCREEN MIRROR BLOCK, COVERS

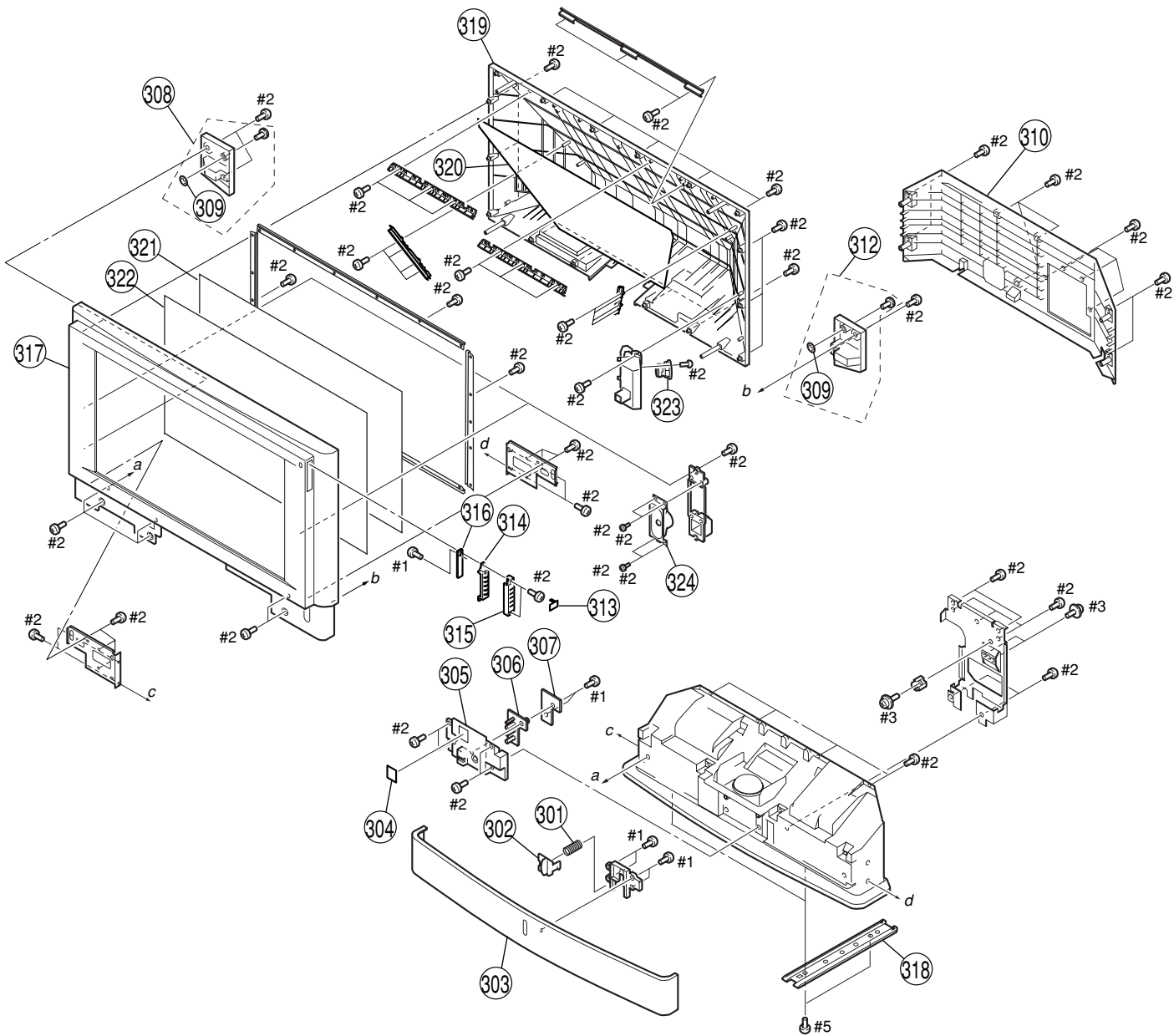

REF. NO.	PART NO.	DESCRIPTION	REMARK	REF. NO.	PART NO.	DESCRIPTION	REMARK
301	4-036-405-01	SPRING, COMPRESSION		316	* A-1405-438-B	H1 BOARD, COMPLETE	
302	4-094-706-01	BUTTON, POWER		317	A-1087-019-A	SCREEN FRAME ASSY(IRP)	
303	X-4042-024-1	COVER ASSY (60), FRONT		318	X-4042-015-2	PLATE (60) ASSY, FOOT	
304	4-097-613-01	SHEET, H2		319	A-1087-020-A	MIRROR COVER ASSY(IRP)	
305	4-095-608-01	BRACKET, H2		320	A-1087-021-A	MIRROR (60) ASSY(IRP)	
306	4-094-707-01	GUIDE (LED), LIGHT		321	4-097-034-11	PLATE (60F), DIFFUSION	
307	* A-1405-436-A	H2 BOARD, COMPLETE		322	4-097-035-11	PLATE (60L), DIFFUSION	
308	X-4042-026-1	CAP (L) ASSY, REAR		323	1-825-586-12	LOUD SPEAKER (10cm)	
309	* 3-650-537-00	WASHER		324	1-825-585-12	LOUD SPEAKER (13X7cm)	
310	4-094-695-21	COVER, REAR		#1	7-685-648-79	SCREW +BVTP 3X12 TYPE2 IT-3	
312	X-4042-025-1	CAP (R) ASSY, REAR		#2	7-685-663-79	SCREW +BVTP 4X16 TYPE2 IT-3	
313	4-094-713-01	CAP, H1 BRACKET		#3	7-682-948-01	SCREW +PSW 3X8	
314	4-094-711-02	BRACKET, H1		#5	7-685-661-71	SCREW +BVTP 4X12 TYPE2 IT-3	
315	4-094-712-01	BUTTON, H1					

Les composants identifiés par une trame et une marque \triangle sont critiques pour la sécurité. Ne les remplacer que par une pièce portant le numéro spécifié.

The components identified by shading and mark \triangle are critical for safety. Replace only with part number specified.

KF-42WE610/50WE610/60WE610

RM-Y913

RM-Y913

RM-Y913

3. BOTTOM BLOCK

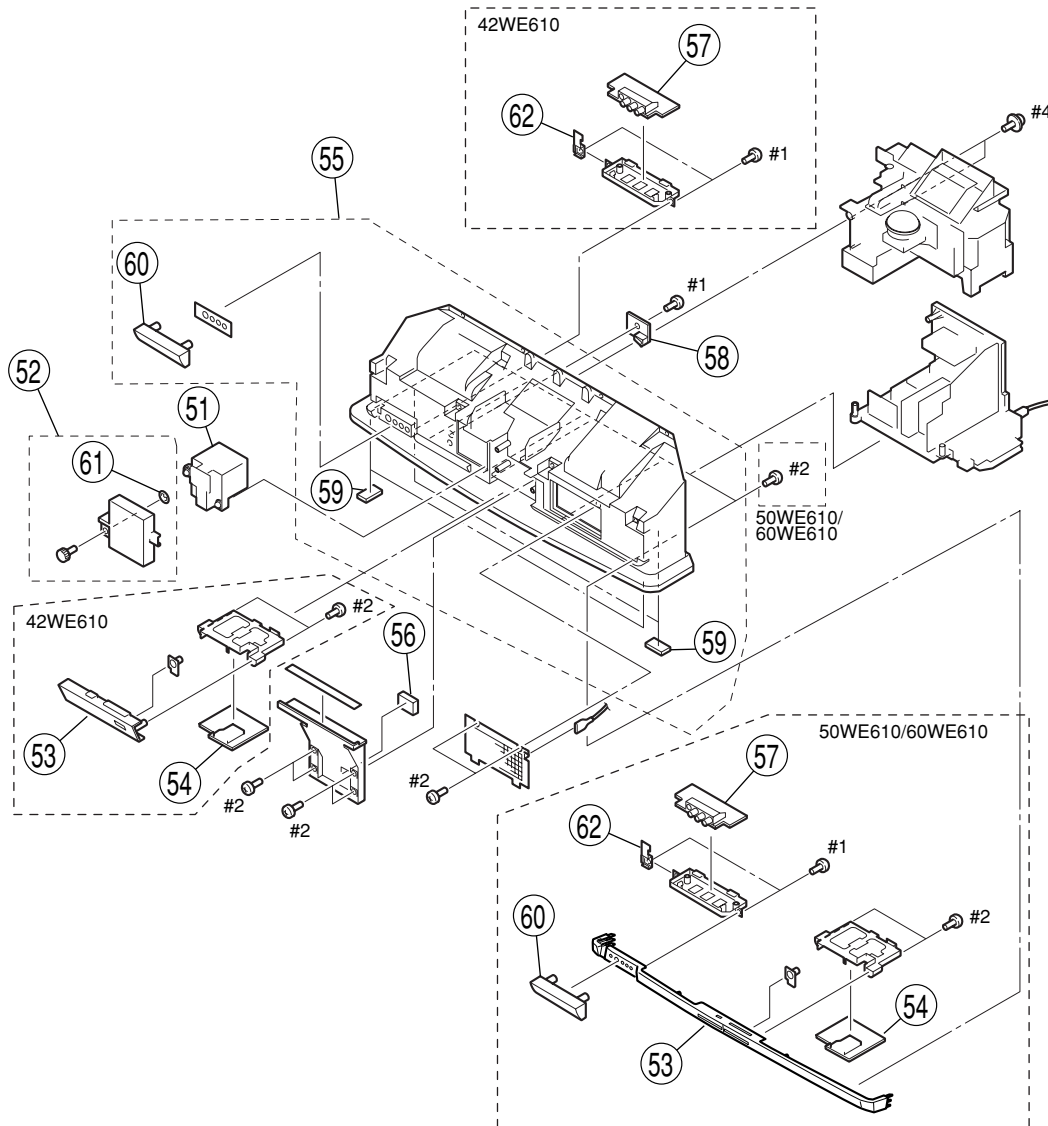

REF. NO.	PART NO.	DESCRIPTION	REMARK	REF. NO.	PART NO.	DESCRIPTION	REMARK
51	\triangle * A-1606-034-A	LAMP BLOCK (RP) ASSY		57	* A-1405-433-A	H3 BOARD, COMPLETE	
52	X-4042-011-1	DOOR ASSY, LAMP		58	* A-1405-434-A	T BOARD, COMPLETE	
53	X-4042-022-1	COVER ASSY (50), BOTTOM (50WE610)		59	4-097-548-01	CUSHION, FOOT	
53	X-4042-029-1	COVER ASSY (60), BOTTOM (60WE610)		60	4-094-721-01	DOOR, H3	
53	4-094-716-01	PANEL, MS (42WE610)		61	* 3-650-537-00	WASHER	
54	* A-1302-276-A	HM BOARD, COMPLETE		62	4-094-757-01	SPRING, PLATE	
55	X-4041-687-1	BOTTOM CABINET ASSY (42WE610)		#1	7-685-648-79	SCREW +BVTP 3X12 TYPE2 IT-3	
55	X-4042-023-1	BOTTOM CABINET ASSY (50) (50WE610)		#2	7-685-663-79	SCREW +BVTP 4X16 TYPE2 IT-3	
55	X-4042-027-1	BOTTOM CABINET ASSY (60) (60WE610)		#4	7-685-167-19	SCREW (WASHER HEAD) (+P 4X35)	
56	4-077-664-01	SHIELD CUSHION (HARNESS)					

4. CHASSIS-1

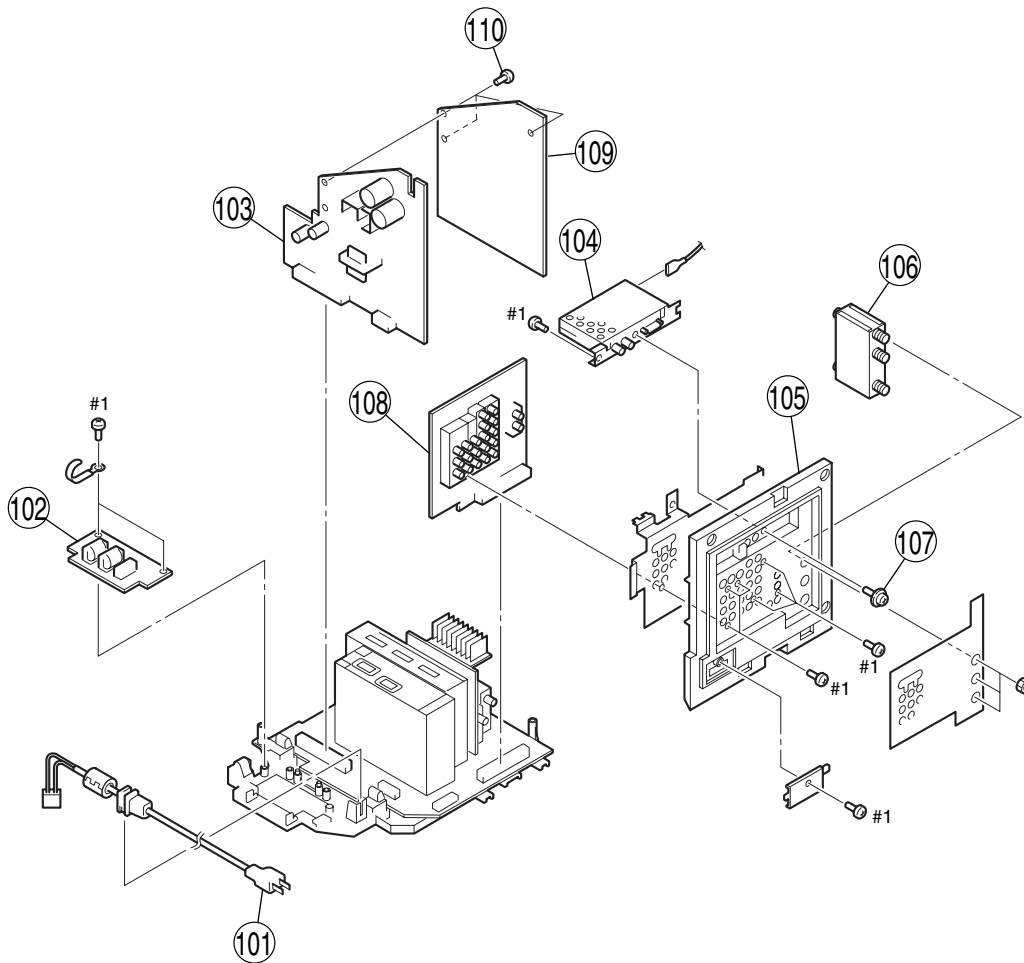

REF. NO.	PART NO.	DESCRIPTION	REMARK	REF. NO.	PART NO.	DESCRIPTION	REMARK
101	△ 1-769-837-11	CORD, POWER(WITH NOISE FILTER)		107	4-382-854-01	SCREW (M3X8), P, SW (+)	
102	* A-1302-273-A	F BOARD, COMPLETE		108	* A-1302-270-A	U BOARD, COMPLETE	
103	* A-1302-272-A	G1 BOARD, COMPLETE		109	4-100-346-01	SHEET G1	
104	* A-1604-652-A	UD BLOCK		110	4-100-521-01	REVERSE LOCK	
105	4-096-935-01	BRACKET, U		#1	7-685-648-79	SCREW +BVTP 3X12 TYPE2 IT-3	
106	1-771-787-13	SWITCH, RF ANTENNA					

5. CHASSIS-2

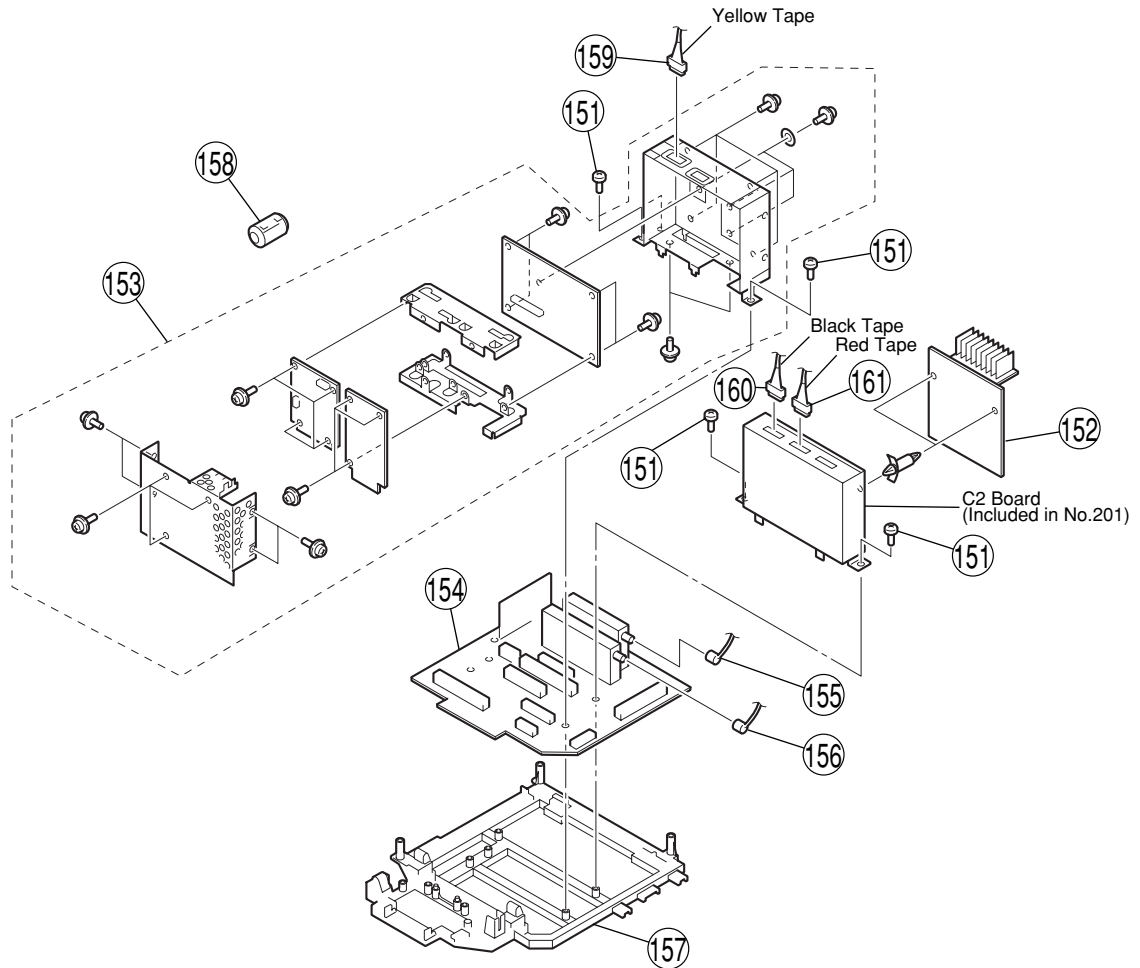

REF. NO.	PART NO.	DESCRIPTION	REMARK	REF. NO.	PART NO.	DESCRIPTION	REMARK
151	4-029-432-01	SCREW (3X12), (+) BVWHTP		154	* A-1302-266-A	A BOARD, COMPLETE	
152	* A-1302-271-A	AU BOARD, COMPLETE		155	* 1-555-110-00	CABLE, P-P	
153	* A-1605-842-A	DIC BLOCK BOARD, COMPLETE ASSY	(60WE610)	156	* 1-557-056-31	CABLE, P-P	
153	* A-1605-853-A	DIC BLOCK BOARD, COMPLETE ASSY	(50WE610)	157	* 4-096-934-01	BRACKET, MAIN	
153	* A-1605-864-A	DIC BLOCK BOARD, COMPLETE ASSY	(42WE610)	158	1-500-603-11	CLAMP, FERRITE	
				159	1-900-277-35	CONNECTOR ASSY 14P (Yellow Tape)	
				160	1-900-277-36	CONNECTOR ASSY 14P (Black Tape)	
				161	1-900-277-37	CONNECTOR ASSY 14P (Red Tape)	

Les composants identifiés par une trame et une marque \triangle sont critiques pour la sécurité. Ne les remplacer que par une pièce portant le numéro spécifié.

The components identified by shading and mark \triangle are critical for safety. Replace only with part number specified.

KF-42WE610/50WE610/60WE610

RM-Y913

RM-Y913

RM-Y913

6. OPTICAL UNIT BLOCK

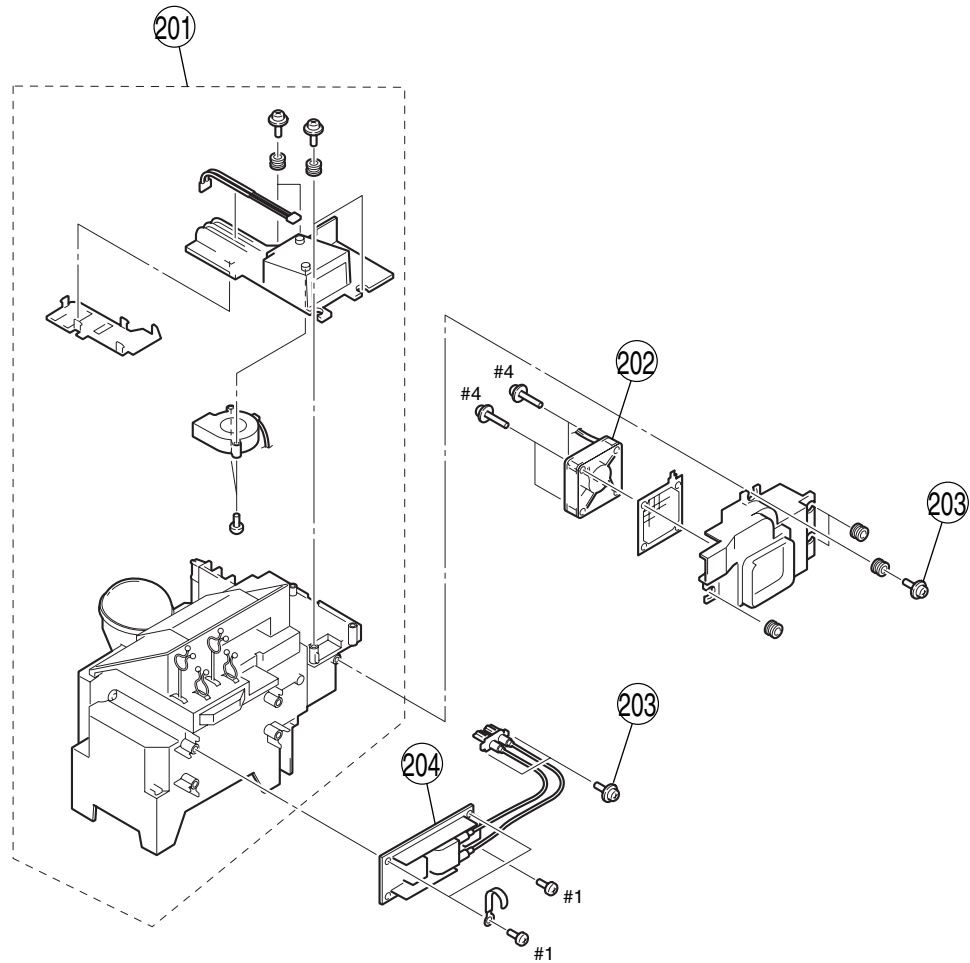

REF. NO.	PART NO.	DESCRIPTION	REMARK	REF. NO.	PART NO.	DESCRIPTION	REMARK
201	\triangle * A-1606-006-A	OPTICAL UNIT BLOCK ASSY (42WE610)		204	\triangle 1-468-798-11	POWER SUPPLY BLOCK	
201	\triangle * A-1606-008-A	OPTICAL UNIT BLOCK ASSY (50WE610)		#1	7-685-648-79	SCREW +BVTP 3X12 TYPE2 IT-3	
201	\triangle * A-1606-010-A	OPTICAL UNIT BLOCK ASSY (60WE610)		#4	7-685-167-19	SCREW (WASHER HEAD) (+P 4X35)	
202	1-787-057-11	D.C. FAN					
203	4-302-404-03	SCREW (WASHER HEAD) (+P 4X16)					

SECTION 6

RM-Y913

RM-Y913

RM-Y913

ELECTRICAL PARTS LIST



The components identified by shading and mark Δ are critical for safety. Replace only with part number specified.

Les composants identifiés par une trame et une marque Δ sont critiques pour la sécurité. Ne les remplacer que par une pièce portant le numéro spécifique.

When indicating parts by reference number, please include the board name.

• Items marked " * " are not stocked since they are seldom required for routine service. Some delay should be anticipated when ordering these items.

• All variable and adjustable resistors have characteristic curve B, unless otherwise noted.

• RESISTORS
All resistors are in ohms
F : nonflammable

• CAPACITORS
PF : $\mu\mu\text{F}$

• There are some cases the reference number on one board overlaps on the other board. Therefore, when ordering parts by the reference number, please include the board name.

REF. NO.	PART NO.	DESCRIPTION	REMARK	REF. NO.	PART NO.	DESCRIPTION	REMARK
*	A-1302-266-A	A BOARD, COMPLETE *****		C8050	1-128-992-21	ELECT CHIP 47 μF	20% 25V
	4-382-854-01	SCREW (M3X8), P, SW (+)		C8051	1-164-156-11	CERAMIC CHIP 0.1 μF	25V
		< CAPACITOR >		C8052	1-164-156-11	CERAMIC CHIP 0.1 μF	25V
C8001	1-128-992-21	ELECT CHIP 47 μF	20% 25V	C8053	1-165-176-11	CERAMIC CHIP 0.047 μF	10% 16V
C8002	1-164-156-11	CERAMIC CHIP 0.1 μF	25V	C8054	1-115-156-11	CERAMIC CHIP 1 μF	10V
C8004	1-164-360-11	CERAMIC CHIP 0.1 μF	16V	C8055	1-164-230-11	CERAMIC CHIP 220pF	5% 50V
C8005	1-124-779-00	ELECT CHIP 10 μF	20% 16V	C8056	1-127-804-91	CERAMIC CHIP 100pF	1% 50V
C8006	1-124-779-00	ELECT CHIP 10 μF	20% 16V	C8057	1-165-176-11	CERAMIC CHIP 0.047 μF	10% 16V
C8007	1-164-360-11	CERAMIC CHIP 0.1 μF	16V	C8058	1-115-156-11	CERAMIC CHIP 1 μF	10V
C8008	1-128-992-21	ELECT CHIP 47 μF	20% 25V	C8059	1-164-230-11	CERAMIC CHIP 220pF	5% 50V
C8012	1-164-156-11	CERAMIC CHIP 0.1 μF	25V	C8061	1-128-995-21	ELECT CHIP 100 μF	20% 10V
C8013	1-164-156-11	CERAMIC CHIP 0.1 μF	25V	C8062	1-128-992-21	ELECT CHIP 47 μF	20% 25V
C8014	1-126-157-11	ELECT 10 μF	20% 16V	C8063	1-164-156-11	CERAMIC CHIP 0.1 μF	25V
C8015	1-162-966-11	CERAMIC CHIP 0.0022 μF	10% 50V	C8064	1-128-992-21	ELECT CHIP 47 μF	20% 25V
C8016	1-126-933-11	ELECT 100 μF	20% 16V	C8065	1-128-992-21	ELECT CHIP 47 μF	20% 25V
C8017	1-126-157-11	ELECT 10 μF	20% 16V	C8066	1-164-156-11	CERAMIC CHIP 0.1 μF	25V
C8018	1-128-992-21	ELECT CHIP 47 μF	20% 25V	C8067	1-164-156-11	CERAMIC CHIP 0.1 μF	25V
C8019	1-128-992-21	ELECT CHIP 47 μF	20% 25V	C8071	1-126-933-11	ELECT 100 μF	20% 16V
C8020	1-164-156-11	CERAMIC CHIP 0.1 μF	25V	C8073	1-107-826-11	CERAMIC CHIP 0.1 μF	10% 16V
C8021	1-164-156-11	CERAMIC CHIP 0.1 μF	25V	C8077	1-124-779-00	ELECT CHIP 10 μF	20% 16V
C8022	1-162-970-11	CERAMIC CHIP 0.01 μF	10% 25V	C8080	1-115-467-11	CERAMIC CHIP 0.22 μF	10% 10V
C8023	1-162-966-11	CERAMIC CHIP 0.0022 μF	10% 50V	C8081	1-164-156-11	CERAMIC CHIP 0.1 μF	25V
C8024	1-126-933-11	ELECT 100 μF	20% 16V	C8083	1-126-926-11	ELECT 1000 μF	20% 10V
C8026	1-162-966-11	CERAMIC CHIP 0.0022 μF	10% 50V	C8084	1-164-156-11	CERAMIC CHIP 0.1 μF	25V
C8027	1-162-970-11	CERAMIC CHIP 0.01 μF	10% 25V	C8085	1-126-941-11	ELECT 470 μF	20% 25V
C8028	1-126-964-11	ELECT 10 μF	20% 50V	C8086	1-164-156-11	CERAMIC CHIP 0.1 μF	25V
C8029	1-126-964-11	ELECT 10 μF	20% 50V	C8087	1-164-156-11	CERAMIC CHIP 0.1 μF	25V
C8030	1-126-967-11	ELECT 47 μF	20% 50V	C8088	1-164-156-11	CERAMIC CHIP 0.1 μF	25V
C8031	1-162-966-11	CERAMIC CHIP 0.0022 μF	10% 50V	C8089	1-128-991-21	ELECT CHIP 10 μF	20% 50V
C8032	1-126-933-11	ELECT 100 μF	20% 16V	C8090	1-164-156-11	CERAMIC CHIP 0.1 μF	25V
C8033	1-162-966-11	CERAMIC CHIP 0.0022 μF	10% 50V	C8091	1-164-156-11	CERAMIC CHIP 0.1 μF	25V
C8034	1-162-966-11	CERAMIC CHIP 0.0022 μF	10% 50V	C8092	1-126-933-11	ELECT 100 μF	20% 16V
C8035	1-126-933-11	ELECT 100 μF	20% 16V	C8585	1-126-964-11	ELECT 10 μF	20% 50V
C8036	1-162-966-11	CERAMIC CHIP 0.0022 μF	10% 50V	C8586	1-126-964-11	ELECT 10 μF	20% 50V
C8037	1-126-933-11	ELECT 100 μF	20% 16V	C8587	1-126-965-91	ELECT 22 μF	20% 50V
C8038	1-126-935-11	ELECT 470 μF	20% 16V	C8590	1-126-965-91	ELECT 22 μF	20% 50V
C8039	1-162-966-11	CERAMIC CHIP 0.0022 μF	10% 50V	C8592	1-127-729-51	ELECT 4700 μF	20% 25V
C8041	1-162-966-11	CERAMIC CHIP 0.0022 μF	10% 50V	C8593	1-164-156-11	CERAMIC CHIP 0.1 μF	25V
C8042	1-126-933-11	ELECT 100 μF	20% 16V	C8595	1-126-965-91	ELECT 22 μF	20% 50V
C8044	1-128-992-21	ELECT CHIP 47 μF	20% 25V	C8597	1-115-339-11	CERAMIC CHIP 0.1 μF	10% 50V
C8045	1-164-156-11	CERAMIC CHIP 0.1 μF	25V	C8600	1-164-156-11	CERAMIC CHIP 0.1 μF	25V
C8046	1-164-156-11	CERAMIC CHIP 0.1 μF	25V	C8602	1-127-729-51	ELECT 4700 μF	20% 25V
C8047	1-126-947-11	ELECT 47 μF	20% 10V	C8603	1-164-156-11	CERAMIC CHIP 0.1 μF	25V
C8048	1-128-992-21	ELECT CHIP 47 μF	20% 25V	C8631	1-107-714-11	ELECT 10 μF	20% 50V
C8049	1-164-156-11	CERAMIC CHIP 0.1 μF	25V	C8632	1-107-703-11	ELECT 220 μF	20% 25V
				C8633	1-107-714-11	ELECT 10 μF	20% 50V
				C8638	1-136-161-00	FILM 0.047 μF	5% 50V
				C8639	1-126-964-11	ELECT 10 μF	20% 50V



REF. NO.	PART NO.	DESCRIPTION	REMARK
C8641	1-136-161-00	FILM	0.047μF 5% 50V
C8649	1-107-826-11	CERAMIC CHIP	0.1μF 10% 16V
C8650	1-126-933-11	ELECT	100μF 20% 16V
C8653	1-126-935-11	ELECT	470μF 20% 16V
C8654	1-136-165-00	FILM	0.1μF 5% 50V
< CONNECTOR >			
*CN8001	1-564-508-11	PLUG, CONNECTOR 5P	
*CN8002	1-564-511-11	PLUG, CONNECTOR 8P	
*CN8003	1-564-508-11	PLUG, CONNECTOR 5P	
*CN8005	1-564-507-11	PLUG, CONNECTOR 4P	
*CN8008	1-793-922-11	CONNECTOR, DIN (RECEPTACLE)64P	
CN8009	1-816-957-11	DIN CONNECTOR (RECEPTACLE) 96P	
CN8010	1-695-915-11	TAB (CONTACT)	
CN8012	1-695-915-11	TAB (CONTACT)	
*CN8013	1-564-507-11	PLUG, CONNECTOR 4P	
*CN8014	1-564-509-11	PLUG, CONNECTOR 6P	
CN8018	1-770-627-21	PIN, CONNECTOR 10P	
*CN8019	1-573-296-21	CONNECTOR, BOARD TO BOARD 10P	
*CN8020	1-764-812-12	CONNECTOR, BOARD TO BOARD 11P	
*CN8021	1-564-510-11	PLUG, CONNECTOR 7P	
*CN8022	1-564-512-11	PLUG, CONNECTOR 9P	
*CN8023	1-564-507-11	PLUG, CONNECTOR 4P	
*CN8024	1-537-711-11	TAB, FASTEN (PCB)	
*CN8025	1-537-711-11	TAB, FASTEN (PCB)	
*CN8036	1-537-738-21	TERMINAL, EARTH	
*CN8037	1-537-738-21	TERMINAL, EARTH	
*CN8038	1-537-738-21	TERMINAL, EARTH	
*CN8039	1-537-738-21	TERMINAL, EARTH	
*CN8040	1-537-738-21	TERMINAL, EARTH	
*CN8501	1-564-506-11	PLUG, CONNECTOR 3P	
CN8901	1-764-610-11	CONNECTOR, BOARD TO BOARD 10P	
*CN8902	1-793-922-11	CONNECTOR, DIN (RECEPTACLE)64P	
CN8903	1-766-388-11	CONNECTOR, BOARD TO BOARD 18P	
< DIODE >			
D8001	8-719-404-50	DIODE MA111-TX	
D8003	8-719-404-50	DIODE MA111-TX	
D8004	8-719-404-50	DIODE MA111-TX	
D8005	8-719-404-50	DIODE MA111-TX	
D8006	8-719-404-50	DIODE MA111-TX	
D8011	8-719-404-50	DIODE MA111-TX	
D8014	8-719-056-85	DIODE UZD-TE-17-8.2B	
D8017	8-719-404-50	DIODE MA111-TX	
D8022	8-719-404-50	DIODE MA111-TX	
D8023	8-719-158-02	DIODE RD3.9SB2	
D8025	8-719-404-50	DIODE MA111-TX	
D8026	8-719-404-50	DIODE MA111-TX	
D8027	8-719-404-50	DIODE MA111-TX	
D8028	8-719-404-50	DIODE MA111-TX	
D8029	8-719-404-50	DIODE MA111-TX	
D8030	8-719-056-78	DIODE UZD-TE-17-4.3B	
D8031	8-719-404-50	DIODE MA111-TX	
D8033	8-719-404-50	DIODE MA111-TX	
D8034	8-719-404-50	DIODE MA111-TX	
D8035	8-719-036-94	DIODE RD5.6SB-T	
D8036	8-719-081-97	DIODE MMDL914T1	
D8037	6-500-527-01	DIODE EC21QS04-TE12L	
D8038	8-719-404-50	DIODE MA111-TX	
D8500	8-719-071-74	DIODE HZU11B1TRF	
D8505	8-719-404-50	DIODE MA111-TX	
D8506	8-719-404-50	DIODE MA111-TX	

REF. NO.	PART NO.	DESCRIPTION	REMARK
D8508	8-719-404-50	DIODE MA111-TX	
D8509	8-719-404-50	DIODE MA111-TX	
D8510	8-719-404-50	DIODE MA111-TX	
D8511	8-719-404-50	DIODE MA111-TX	
< FERRITE BEAD >			
FB8001	1-216-295-91	SHORT CHIP	0
FB8002	1-414-228-11	FERRITE	0μH
FB8003	1-414-228-11	FERRITE	0μH
FB8004	1-216-295-91	SHORT CHIP	0
FB8005	1-216-295-91	SHORT CHIP	0
FB8006	1-216-295-91	SHORT CHIP	0
FB8007	1-216-295-91	SHORT CHIP	0
FB8008	1-216-295-91	SHORT CHIP	0
FB8009	1-216-295-91	SHORT CHIP	0
FB8010	1-216-295-91	SHORT CHIP	0
FB8011	1-216-295-91	SHORT CHIP	0
FB8012	1-414-233-22	FERRITE	0μH
FB8013	1-414-233-22	FERRITE	0μH
FB8014	1-414-233-22	FERRITE	0μH
FB8015	1-414-233-22	FERRITE	0μH
FB8016	1-414-921-11	FERRITE	0μH
FB8017	1-469-869-21	FERRITE	0μH
< IC >			
IC8001	8-759-687-14	IC MAX4451EKA-TG069	
IC8003	6-705-025-01	IC PQ20WZ1UJ00H	
IC8005	6-705-025-01	IC PQ20WZ1UJ00H	
IC8006	6-705-025-01	IC PQ20WZ1UJ00H	
IC8007	6-705-025-01	IC PQ20WZ1UJ00H	
IC8008	8-759-663-29	IC MM1476AF(TP)	
IC8009	6-700-813-01	IC SI-8033JF	
IC8010	8-752-072-94	IC CXA1875AM-T4	
IC8504	8-759-584-38	IC TDA7296	
IC8507	8-759-278-58	IC NJM4558V-TE2	
< COIL >			
L8001	1-469-320-21	INDUCTOR	100μH
L8003	1-414-183-41	INDUCTOR	10μH
L8004	1-469-320-21	INDUCTOR	100μH
L8005	1-469-320-21	INDUCTOR	100μH
L8006	1-469-317-21	INDUCTOR	10μH
L8007	1-469-320-21	INDUCTOR	100μH
L8008	1-469-320-21	INDUCTOR	100μH
L8009	1-469-317-21	INDUCTOR	10μH
L8010	1-412-525-31	INDUCTOR	10μH
L8011	1-456-214-11	COIL, CHOPPER	
L8013	1-469-555-21	INDUCTOR	10μH
L8506	1-469-559-21	INDUCTOR	47μH
< TRANSISTOR >			
Q8001	8-729-120-28	TRANSISTOR 2SC1623-L5L6	
Q8002	8-729-120-28	TRANSISTOR 2SC1623-L5L6	
Q8003	8-729-900-53	TRANSISTOR DTC114EK	
Q8004	8-729-216-22	TRANSISTOR 2SA1162-G	
Q8005	8-729-422-27	TRANSISTOR 2SD601A-Q	
Q8006	8-729-422-27	TRANSISTOR 2SD601A-Q	
Q8008	8-729-216-22	TRANSISTOR 2SA1162-G	
Q8009	8-729-422-27	TRANSISTOR 2SD601A-Q	
Q8014	8-729-905-35	TRANSISTOR 2SC4081-R	
Q8015	8-729-026-53	TRANSISTOR 2SA1576A-T106-QR	



REF. NO.	PART NO.	DESCRIPTION	REMARK
Q8016	8-729-905-35	TRANSISTOR 2SC4081-R	
Q8017	8-729-026-53	TRANSISTOR 2SA1576A-T106-QR	
Q8018	8-729-905-35	TRANSISTOR 2SC4081-R	
Q8019	8-729-422-27	TRANSISTOR 2SD601A-Q	
Q8021	8-729-422-27	TRANSISTOR 2SD601A-Q	
Q8022	8-729-026-53	TRANSISTOR 2SA1576A-T106-QR	
Q8023	8-729-422-27	TRANSISTOR 2SD601A-Q	
Q8024	8-729-900-53	TRANSISTOR DTC114EK	
Q8025	8-729-422-27	TRANSISTOR 2SD601A-Q	
Q8027	8-729-422-27	TRANSISTOR 2SD601A-Q	
Q8029	8-729-216-22	TRANSISTOR 2SA1162-G	
Q8030	8-729-216-22	TRANSISTOR 2SA1162-G	
Q8034	8-729-422-27	TRANSISTOR 2SD601A-Q	
Q8035	8-729-216-22	TRANSISTOR 2SA1162-G	
Q8036	8-729-422-27	TRANSISTOR 2SD601A-Q	
Q8037	8-729-422-27	TRANSISTOR 2SD601A-Q	
Q8039	8-729-422-27	TRANSISTOR 2SD601A-Q	
Q8041	8-729-216-22	TRANSISTOR 2SA1162-G	
Q8044	8-729-422-27	TRANSISTOR 2SD601A-Q	
Q8045	8-729-422-27	TRANSISTOR 2SD601A-Q	
Q8046	8-729-422-27	TRANSISTOR 2SD601A-Q	
Q8047	8-729-216-22	TRANSISTOR 2SA1162-G	
Q8048	8-729-216-22	TRANSISTOR 2SA1162-G	
Q8049	8-729-216-22	TRANSISTOR 2SA1162-G	
Q8051	8-729-216-22	TRANSISTOR 2SA1162-G	
Q8052	8-729-216-22	TRANSISTOR 2SA1162-G	
Q8500	8-729-422-27	TRANSISTOR 2SD601A-Q	
Q8503	8-729-422-27	TRANSISTOR 2SD601A-Q	
Q8504	8-729-422-27	TRANSISTOR 2SD601A-Q	
Q8507	8-729-216-22	TRANSISTOR 2SA1162-G	
Q8508	8-729-422-27	TRANSISTOR 2SD601A-Q	
Q8509	8-729-422-27	TRANSISTOR 2SD601A-Q	
Q8510	8-729-216-22	TRANSISTOR 2SA1162-G	
Q8512	8-729-216-22	TRANSISTOR 2SA1162-G	
Q8513	8-729-422-27	TRANSISTOR 2SD601A-Q	
< RESISTOR >			
R8003	1-216-833-11	METAL CHIP 10K	5% 1/10W
R8004	1-216-833-11	METAL CHIP 10K	5% 1/10W
R8005	1-216-825-11	METAL CHIP 2.2K	5% 1/10W
R8006	1-216-837-11	METAL CHIP 22K	5% 1/10W
R8007	1-218-691-11	METAL CHIP 910	0.5% 1/10W
R8008	1-218-704-11	METAL CHIP 3.3K	0.5% 1/10W
R8010	1-216-827-11	METAL CHIP 3.3K	5% 1/10W
R8011	1-216-833-11	METAL CHIP 10K	5% 1/10W
R8012	1-216-864-11	SHORT CHIP 0	
R8013	1-216-864-11	SHORT CHIP 0	
R8014	1-216-809-11	METAL CHIP 100	5% 1/10W
R8015	1-216-833-11	METAL CHIP 10K	5% 1/10W
R8016	1-216-833-11	METAL CHIP 10K	5% 1/10W
R8019	1-216-833-11	METAL CHIP 10K	5% 1/10W
R8022	1-216-833-11	METAL CHIP 10K	5% 1/10W
R8023	1-216-833-11	METAL CHIP 10K	5% 1/10W
R8024	1-216-833-11	METAL CHIP 10K	5% 1/10W
R8027	1-218-652-11	METAL CHIP 22	0.5% 1/10W
R8028	1-216-809-11	METAL CHIP 100	5% 1/10W
R8029	1-218-693-11	METAL CHIP 1.1K	0.5% 1/10W
R8034	1-218-692-11	METAL CHIP 1K	0.5% 1/10W
R8038	1-216-845-11	METAL CHIP 100K	5% 1/10W
R8039	1-218-660-91	METAL CHIP 47	0.5% 1/10W
R8041	1-216-864-11	SHORT CHIP 0	
R8042	1-218-668-11	METAL CHIP 100	0.5% 1/10W
R8043	1-216-809-11	METAL CHIP 100	5% 1/10W

REF. NO.	PART NO.	DESCRIPTION	REMARK
R8044	1-216-820-11	METAL CHIP 820	5% 1/10W
R8045	1-218-722-11	METAL CHIP 18K	0.5% 1/10W
R8048	1-218-692-11	METAL CHIP 1K	0.5% 1/10W
R8050	1-218-660-91	METAL CHIP 47	0.5% 1/10W
R8052	1-218-716-11	METAL CHIP 10K	0.5% 1/10W
R8055	1-216-809-11	METAL CHIP 100	5% 1/10W
R8056	1-218-668-11	METAL CHIP 100	0.5% 1/10W
R8057	1-216-839-11	METAL CHIP 33K	5% 1/10W
R8058	1-216-833-11	METAL CHIP 10K	5% 1/10W
R8060	1-216-864-11	SHORT CHIP 0	
R8061	1-216-827-11	METAL CHIP 3.3K	5% 1/10W
R8062	1-216-820-11	METAL CHIP 820	5% 1/10W
R8063	1-216-839-11	METAL CHIP 33K	5% 1/10W
R8064	1-218-692-11	METAL CHIP 1K	0.5% 1/10W
R8065	1-216-825-11	METAL CHIP 2.2K	5% 1/10W
R8066	1-216-864-11	SHORT CHIP 0	
R8067	1-216-809-11	METAL CHIP 100	5% 1/10W
R8068	1-216-809-11	METAL CHIP 100	5% 1/10W
R8070	1-216-825-11	METAL CHIP 2.2K	5% 1/10W
R8071	1-216-837-11	METAL CHIP 22K	5% 1/10W
R8072	1-216-864-11	SHORT CHIP 0	
R8073	1-216-821-11	METAL CHIP 1K	5% 1/10W
R8074	1-216-809-11	METAL CHIP 100	5% 1/10W
R8075	1-216-809-11	METAL CHIP 100	5% 1/10W
R8076	1-216-864-11	SHORT CHIP 0	
R8077	1-216-837-11	METAL CHIP 22K	5% 1/10W
R8078	1-218-660-91	METAL CHIP 47	0.5% 1/10W
R8079	1-216-847-11	METAL CHIP 150K	5% 1/10W
R8080	1-218-668-11	METAL CHIP 100	0.5% 1/10W
R8081	1-216-847-11	METAL CHIP 150K	5% 1/10W
R8082	1-216-833-11	METAL CHIP 10K	5% 1/10W
R8083	1-216-820-11	METAL CHIP 820	5% 1/10W
R8084	1-216-805-11	METAL CHIP 47	5% 1/10W
R8085	1-216-805-11	METAL CHIP 47	5% 1/10W
R8086	1-216-805-11	METAL CHIP 47	5% 1/10W
R8087	1-216-805-11	METAL CHIP 47	5% 1/10W
R8088	1-216-824-11	METAL CHIP 1.8K	5% 1/10W
R8089	1-216-833-11	METAL CHIP 10K	5% 1/10W
R8091	1-216-825-11	METAL CHIP 2.2K	5% 1/10W
R8093	1-216-833-11	METAL CHIP 10K	5% 1/10W
R8098	1-216-825-11	METAL CHIP 2.2K	5% 1/10W
R8099	1-216-864-11	SHORT CHIP 0	
R8100	1-216-864-11	SHORT CHIP 0	
R8101	1-218-722-11	METAL CHIP 18K	0.5% 1/10W
R8102	1-216-864-11	SHORT CHIP 0	
R8103	1-216-813-11	METAL CHIP 220	5% 1/10W
R8105	1-218-716-11	METAL CHIP 10K	0.5% 1/10W
R8108	1-216-864-11	SHORT CHIP 0	
R8109	1-216-864-11	SHORT CHIP 0	
R8110	1-216-847-11	METAL CHIP 150K	5% 1/10W
R8111	1-216-823-11	METAL CHIP 1.5K	5% 1/10W
R8112	1-216-829-11	METAL CHIP 4.7K	5% 1/10W
R8113	1-216-857-11	METAL CHIP 1M	5% 1/10W
R8114	1-216-833-11	METAL CHIP 10K	5% 1/10W
R8115	1-216-833-11	METAL CHIP 10K	5% 1/10W
R8116	1-216-847-11	METAL CHIP 150K	5% 1/10W
R8117	1-216-825-11	METAL CHIP 2.2K	5% 1/10W
R8118	1-216-829-11	METAL CHIP 4.7K	5% 1/10W
R8119	1-216-857-11	METAL CHIP 1M	5% 1/10W
R8120	1-216-833-11	METAL CHIP 10K	5% 1/10W
R8121	1-216-833-11	METAL CHIP 10K	5% 1/10W
R8122	1-216-864-11	SHORT CHIP 0	
R8123	1-216-864-11	SHORT CHIP 0	
R8124	1-216-864-11	SHORT CHIP 0	



REF. NO.	PART NO.	DESCRIPTION		REMARK
R8125	1-218-722-11	METAL CHIP	18K	0.5% 1/10W
R8127	1-218-716-11	METAL CHIP	10K	0.5% 1/10W
R8131	1-216-864-11	SHORT CHIP	0	
R8134	1-216-821-11	METAL CHIP	1K	5% 1/10W
R8138	1-216-833-11	METAL CHIP	10K	5% 1/10W
R8139	1-216-864-11	SHORT CHIP	0	
R8140	1-216-864-11	SHORT CHIP	0	
R8141	1-216-864-11	SHORT CHIP	0	
R8142	1-216-864-11	SHORT CHIP	0	
R8143	1-216-864-11	SHORT CHIP	0	
R8144	1-216-864-11	SHORT CHIP	0	
R8145	1-216-864-11	SHORT CHIP	0	
R8146	1-216-864-11	SHORT CHIP	0	
R8147	1-216-845-11	METAL CHIP	100K	5% 1/10W
R8148	1-216-864-11	SHORT CHIP	0	
R8151	1-216-845-11	METAL CHIP	100K	5% 1/10W
R8152	1-216-841-11	METAL CHIP	47K	5% 1/10W
R8153	1-216-833-11	METAL CHIP	10K	5% 1/10W
R8155	1-216-845-11	METAL CHIP	100K	5% 1/10W
R8156	1-216-845-11	METAL CHIP	100K	5% 1/10W
R8157	1-216-825-11	METAL CHIP	2.2K	5% 1/10W
R8159	1-216-825-11	METAL CHIP	2.2K	5% 1/10W
R8160	1-216-849-11	METAL CHIP	220K	5% 1/10W
R8161	1-216-841-11	METAL CHIP	47K	5% 1/10W
R8162	1-216-833-11	METAL CHIP	10K	5% 1/10W
R8164	1-216-845-11	METAL CHIP	100K	5% 1/10W
R8179	1-216-833-11	METAL CHIP	10K	5% 1/10W
R8180	1-216-833-11	METAL CHIP	10K	5% 1/10W
R8183	1-216-803-11	METAL CHIP	33	5% 1/10W
R8184	1-216-821-11	METAL CHIP	1K	5% 1/10W
R8185	1-216-821-11	METAL CHIP	1K	5% 1/10W
R8190	1-216-845-11	METAL CHIP	100K	5% 1/10W
R8191	1-216-821-11	METAL CHIP	1K	5% 1/10W
R8192	1-216-845-11	METAL CHIP	100K	5% 1/10W
R8193	1-216-797-11	METAL CHIP	10	5% 1/10W
R8194	1-216-821-11	METAL CHIP	1K	5% 1/10W
R8195	1-216-845-11	METAL CHIP	100K	5% 1/10W
R8196	1-216-845-11	METAL CHIP	100K	5% 1/10W
R8197	1-216-797-11	METAL CHIP	10	5% 1/10W
R8198	1-216-845-11	METAL CHIP	100K	5% 1/10W
R8199	1-216-821-11	METAL CHIP	1K	5% 1/10W
R8200	1-216-845-11	METAL CHIP	100K	5% 1/10W
R8201	1-216-797-11	METAL CHIP	10	5% 1/10W
R8202	1-216-833-11	METAL CHIP	10K	5% 1/10W
R8203	1-216-833-11	METAL CHIP	10K	5% 1/10W
R8204	1-216-833-11	METAL CHIP	10K	5% 1/10W
R8205	1-216-864-11	SHORT CHIP	0	
R8206	1-216-864-11	SHORT CHIP	0	
R8207	1-216-864-11	SHORT CHIP	0	
R8208	1-216-864-11	SHORT CHIP	0	
R8209	1-216-864-11	SHORT CHIP	0	
R8210	1-216-864-11	SHORT CHIP	0	
R8211	1-216-864-11	SHORT CHIP	0	
R8217	1-216-864-11	SHORT CHIP	0	
R8218	1-216-864-11	SHORT CHIP	0	
R8219	1-216-864-11	SHORT CHIP	0	
R8220	1-216-864-11	SHORT CHIP	0	
R8221	1-216-864-11	SHORT CHIP	0	
R8227	1-216-801-11	METAL CHIP	22	5% 1/10W
R8228	1-216-801-11	METAL CHIP	22	5% 1/10W
R8236	1-216-806-11	METAL CHIP	56	5% 1/10W
R8237	1-216-825-11	METAL CHIP	2.2K	5% 1/10W
R8238	1-216-809-11	METAL CHIP	100	5% 1/10W
R8239	1-216-825-11	METAL CHIP	2.2K	5% 1/10W

REF. NO.	PART NO.	DESCRIPTION		REMARK
R8240	1-216-809-11	METAL CHIP	100	5% 1/10W
R8241	1-216-806-11	METAL CHIP	56	5% 1/10W
R8245	1-216-835-11	METAL CHIP	15K	5% 1/10W
R8246	1-216-835-11	METAL CHIP	15K	5% 1/10W
R8247	1-216-835-11	METAL CHIP	15K	5% 1/10W
R8251	1-216-833-11	METAL CHIP	10K	5% 1/10W
R8252	1-216-833-11	METAL CHIP	10K	5% 1/10W
R8253	1-216-833-11	METAL CHIP	10K	5% 1/10W
R8254	1-216-833-11	METAL CHIP	10K	5% 1/10W
R8578	1-216-828-11	METAL CHIP	3.9K	5% 1/10W
R8579	1-216-837-11	METAL CHIP	22K	5% 1/10W
R8580	1-216-819-11	METAL CHIP	680	5% 1/10W
R8581	1-216-826-11	METAL CHIP	2.7K	5% 1/10W
R8583	1-216-837-11	METAL CHIP	22K	5% 1/10W
R8587	1-216-839-11	METAL CHIP	33K	5% 1/10W
R8591	1-216-837-11	METAL CHIP	22K	5% 1/10W
R8592	1-216-841-11	METAL CHIP	47K	5% 1/10W
R8593	1-216-841-11	METAL CHIP	47K	5% 1/10W
R8609	1-216-837-11	METAL CHIP	22K	5% 1/10W
R8614	1-216-834-11	METAL CHIP	12K	5% 1/10W
R8615	1-216-864-11	SHORT CHIP	0	
R8616	1-216-825-11	METAL CHIP	2.2K	5% 1/10W
R8617	1-216-837-11	METAL CHIP	22K	5% 1/10W
R8619	1-216-864-11	SHORT CHIP	0	
R8620	1-216-809-11	METAL CHIP	100	5% 1/10W
R8621	1-216-841-11	METAL CHIP	47K	5% 1/10W
R8627	1-216-834-11	METAL CHIP	12K	5% 1/10W
R8628	1-216-825-11	METAL CHIP	2.2K	5% 1/10W
R8631	1-216-821-11	METAL CHIP	1K	5% 1/10W
R8632	1-216-821-11	METAL CHIP	1K	5% 1/10W
R8636	1-216-843-11	METAL CHIP	68K	5% 1/10W
R8637	1-216-841-11	METAL CHIP	47K	5% 1/10W
R8638	1-216-841-11	METAL CHIP	47K	5% 1/10W
R8640	1-216-843-11	METAL CHIP	68K	5% 1/10W
R8641	1-216-834-11	METAL CHIP	12K	5% 1/10W
R8642	1-216-833-11	METAL CHIP	10K	5% 1/10W
R8645	1-216-814-11	METAL CHIP	270	5% 1/10W
R8646	1-216-839-11	METAL CHIP	33K	5% 1/10W
R8647	1-216-809-11	METAL CHIP	100	5% 1/10W
R8650	1-216-837-11	METAL CHIP	22K	5% 1/10W
R8654	1-216-864-11	SHORT CHIP	0	
R8656	1-216-834-11	METAL CHIP	12K	5% 1/10W
R8658	1-216-809-11	METAL CHIP	100	5% 1/10W
R8668	1-216-864-11	SHORT CHIP	0	
R8669	1-216-841-11	METAL CHIP	47K	5% 1/10W
R8670	1-216-837-11	METAL CHIP	22K	5% 1/10W
R8671	1-216-864-11	SHORT CHIP	0	
R8672	1-216-809-11	METAL CHIP	100	5% 1/10W
R8673	1-216-833-11	METAL CHIP	10K	5% 1/10W
R8674	1-218-867-11	METAL CHIP	6.8K	0.5% 1/10W
R8675	1-216-839-11	METAL CHIP	33K	5% 1/10W
R8676	1-216-357-00	METAL OXIDE	4.7	5% 1W
R8677	1-216-833-11	METAL CHIP	10K	5% 1/10W
R8678	1-216-833-11	METAL CHIP	10K	5% 1/10W

< TUNER >

TU8001 8-598-594-10 TUNER, FSS BTF-FA421
 TU8002 8-598-593-20 TUNER, FSS BTF-WA421



REF. NO.	PART NO.	DESCRIPTION	REMARK
*	A-1302-271-A	AU BOARD, COMPLETE *****	
*	4-042-408-01	PIN, COATING LEAD	
	4-382-854-01	SCREW (M3X8), P, SW (+)	
< CAPACITOR >			
C4701	1-126-964-11	ELECT	10µF 20% 50V
C4702	1-126-964-11	ELECT	10µF 20% 50V
C4703	1-126-964-11	ELECT	10µF 20% 50V
C4704	1-126-964-11	ELECT	10µF 20% 50V
C4705	1-136-167-00	FILM	0.15µF 5% 50V
C4706	1-130-469-00	MYLAR	680pF 5% 50V
C4707	1-136-158-00	FILM	0.027µF 5% 50V
C4708	1-130-471-00	MYLAR	0.001µF 5% 50V
C4709	1-164-227-11	CERAMIC CHIP	0.022µF 10% 25V
C4710	1-127-715-91	CERAMIC CHIP	0.22µF 10% 16V
C4711	1-162-970-11	CERAMIC CHIP	0.01µF 10% 25V
C4713	1-128-934-91	CERAMIC CHIP	0.33µF 20% 10V
C4714	1-126-968-11	ELECT	100µF 20% 50V
C4715	1-162-968-11	CERAMIC CHIP	0.0047µF 10% 50V
C4716	1-127-715-91	CERAMIC CHIP	0.22µF 10% 16V
C4717	1-126-964-11	ELECT	10µF 20% 50V
C4718	1-126-964-11	ELECT	10µF 20% 50V
C4719	1-127-715-91	CERAMIC CHIP	0.22µF 10% 16V
C4720	1-127-715-91	CERAMIC CHIP	0.22µF 10% 16V
C4721	1-127-715-91	CERAMIC CHIP	0.22µF 10% 16V
C4722	1-107-826-11	CERAMIC CHIP	0.1µF 10% 16V
C4723	1-127-715-91	CERAMIC CHIP	0.22µF 10% 16V
C4724	1-127-715-91	CERAMIC CHIP	0.22µF 10% 16V
C4726	1-127-715-91	CERAMIC CHIP	0.22µF 10% 16V
C4727	1-127-722-91	ELECT	2200µF 20% 16V
C4728	1-162-968-11	CERAMIC CHIP	0.0047µF 10% 50V
C4729	1-162-970-11	CERAMIC CHIP	0.01µF 10% 25V
C4730	1-126-963-11	ELECT	4.7µF 20% 50V
C4731	1-126-964-11	ELECT	10µF 20% 50V
C4732	1-162-968-11	CERAMIC CHIP	0.0047µF 10% 50V
C4733	1-126-964-11	ELECT	10µF 20% 50V
C4734	1-126-964-11	ELECT	10µF 20% 50V
C4735	1-136-167-00	FILM	0.15µF 5% 50V
C4736	1-130-469-00	MYLAR	680pF 5% 50V
C4737	1-136-158-00	FILM	0.027µF 5% 50V
C4738	1-130-471-00	MYLAR	0.001µF 5% 50V
C4739	1-126-960-11	ELECT	1µF 20% 50V
C4740	1-126-961-11	ELECT	2.2µF 20% 50V
C4741	1-126-961-11	ELECT	2.2µF 20% 50V
C4742	1-126-964-11	ELECT	10µF 20% 50V
C4743	1-162-968-11	CERAMIC CHIP	0.0047µF 10% 50V
C4744	1-162-968-11	CERAMIC CHIP	0.0047µF 10% 50V
C4745	1-162-970-11	CERAMIC CHIP	0.01µF 10% 25V
C4749	1-136-159-00	FILM	0.033µF 5% 50V
C4750	1-126-963-11	ELECT	4.7µF 20% 50V
C4751	1-136-159-00	FILM	0.033µF 5% 50V
C4752	1-136-167-00	FILM	0.15µF 5% 50V
C4753	1-126-963-11	ELECT	4.7µF 20% 50V
C4754	1-126-962-11	ELECT	3.3µF 20% 50V
C4755	1-136-159-00	FILM	0.033µF 5% 50V
C4756	1-136-167-00	FILM	0.15µF 5% 50V
C4757	1-136-159-00	FILM	0.033µF 5% 50V
C4759	1-162-915-11	CERAMIC CHIP	10pF 0.50pF 50V
C4760	1-126-964-11	ELECT	10µF 20% 50V
C4762	1-126-962-11	ELECT	3.3µF 20% 50V
C4763	1-107-703-11	ELECT	220µF 20% 25V

REF. NO.	PART NO.	DESCRIPTION	REMARK
C4764	1-126-964-11	ELECT	10µF 20% 50V
C4766	1-136-165-00	FILM	0.1µF 5% 50V
C4767	1-136-165-00	FILM	0.1µF 5% 50V
C4768	1-126-968-11	ELECT	100µF 20% 50V
C4769	1-115-339-11	CERAMIC CHIP	0.1µF 10% 50V
C4770	1-126-968-11	ELECT	100µF 20% 50V
C4771	1-115-339-11	CERAMIC CHIP	0.1µF 10% 50V
C4772	1-107-826-11	CERAMIC CHIP	0.1µF 10% 16V
C4773	1-126-967-11	ELECT	47µF 20% 50V
C4774	1-162-923-11	CERAMIC CHIP	47pF 5% 50V
C4775	1-162-923-11	CERAMIC CHIP	47pF 5% 50V
C4776	1-162-923-11	CERAMIC CHIP	47pF 5% 50V
C4779	1-162-923-11	CERAMIC CHIP	47pF 5% 50V
C4780	1-136-161-00	FILM	0.047µF 5% 50V
C4781	1-136-161-00	FILM	0.047µF 5% 50V
C4782	1-126-964-11	ELECT	10µF 20% 50V
C4783	1-126-964-11	ELECT	10µF 20% 50V
C4784	1-126-964-11	ELECT	10µF 20% 50V
C4785	1-126-964-11	ELECT	10µF 20% 50V
C4786	1-107-826-11	CERAMIC CHIP	0.1µF 10% 16V
C4787	1-107-826-11	CERAMIC CHIP	0.1µF 10% 16V
C4788	1-162-915-11	CERAMIC CHIP	10pF 0.50pF 50V
< CONNECTOR >			
CN4702	1-766-391-11	CONNECTOR, BOARD TO BOARD 18P	
*CN4703	1-564-519-11	PLUG, CONNECTOR 4P	
CN4704	1-695-915-11	TAB (CONTACT)	
CN4706	1-535-877-22	CHIP, CHECKER	
CN4707	1-535-877-22	CHIP, CHECKER	
CN4708	1-535-877-22	CHIP, CHECKER	
< DIODE >			
D4701	8-719-071-74	DIODE HZU11B1TRF	
D4702	8-719-050-37	DIODE M1MA152WA-T1	
D4703	8-719-050-38	DIODE M1MA152WK-T1	
D4704	8-719-404-50	DIODE MA111-TX	
D4705	8-719-404-50	DIODE MA111-TX	
D4707	8-719-404-50	DIODE MA111-TX	
D4709	8-719-404-50	DIODE MA111-TX	
D4710	8-719-404-50	DIODE MA111-TX	
D4711	8-719-404-50	DIODE MA111-TX	
D4712	8-719-404-50	DIODE MA111-TX	
< IC >			
IC4701	6-702-716-01	IC NJW1149	
IC4702	8-759-278-58	IC NJM4558V-TE2	
IC4703	6-702-295-01	IC NJM78M12DL1A-TE1	
IC4704	8-759-190-89	IC TDA7265	
IC4705	6-702-297-01	IC NJM79M12DL1A-TE1	
< COIL >			
L4701	1-414-187-11	INDUCTOR	47µH
< TRANSISTOR >			
Q4701	8-729-422-27	TRANSISTOR 2SD601A-Q	
Q4702	8-729-422-27	TRANSISTOR 2SD601A-Q	
Q4703	8-729-422-27	TRANSISTOR 2SD601A-Q	
Q4704	8-729-216-22	TRANSISTOR 2SA1162-G	
Q4705	8-729-027-55	TRANSISTOR DTC143EKA-T146	

Les composants identifiés par une trame et une marque Δ sont critiques pour la sécurité. Ne les remplacer que par une pièce portant le numéro spécifique.

The components identified by shading and mark Δ are critical for safety. Replace only with part number specified.

KF-42WE610/50WE610/60WE610

RM-Y913

RM-Y913

RM-Y913



REF. NO.	PART NO.	DESCRIPTION	REMARK		
Q4706	8-729-422-27	TRANSISTOR 2SD601A-Q			
Q4707	8-729-422-27	TRANSISTOR 2SD601A-Q			
Q4708	8-729-216-22	TRANSISTOR 2SA1162-G			
Q4709	8-729-422-27	TRANSISTOR 2SD601A-Q			
Q4710	8-729-905-35	TRANSISTOR 2SC4081-R			
Q4711	8-729-905-35	TRANSISTOR 2SC4081-R			
Q4712	8-729-905-35	TRANSISTOR 2SC4081-R			
Q4713	8-729-905-35	TRANSISTOR 2SC4081-R			
< RESISTOR >					
R4701	1-216-825-11	METAL CHIP 2.2K	5%	1/10W	
R4702	1-216-825-11	METAL CHIP 2.2K	5%	1/10W	
R4703	1-218-867-11	METAL CHIP 6.8K	0.5%	1/10W	
R4704	1-218-867-11	METAL CHIP 6.8K	0.5%	1/10W	
R4705	1-216-864-11	SHORT CHIP 0			
R4706	1-216-830-11	METAL CHIP 5.6K	5%	1/10W	
R4707	1-216-836-11	METAL CHIP 18K	5%	1/10W	
R4708	1-216-801-11	METAL CHIP 22	5%	1/10W	
R4709	1-216-801-11	METAL CHIP 22	5%	1/10W	
R4710	1-218-292-11	METAL CHIP 20K	5%	1/10W	
R4711	1-218-292-11	METAL CHIP 20K	5%	1/10W	
R4718	1-216-864-11	SHORT CHIP 0			
R4721	1-216-864-11	SHORT CHIP 0			
R4722	1-216-864-11	SHORT CHIP 0			
R4723	1-216-864-11	SHORT CHIP 0			
R4725	1-216-837-11	METAL CHIP 22K	5%	1/10W	
R4727	1-216-845-11	METAL CHIP 100K	5%	1/10W	
R4728	1-216-826-11	METAL CHIP 2.7K	5%	1/10W	
R4729	1-216-841-11	METAL CHIP 47K	5%	1/10W	
R4732	1-216-833-11	METAL CHIP 10K	5%	1/10W	
R4733	1-216-826-11	METAL CHIP 2.7K	5%	1/10W	
R4734	1-216-864-11	SHORT CHIP 0			
R4735	1-216-864-11	SHORT CHIP 0			
R4736	1-216-822-11	METAL CHIP 1.2K	5%	1/10W	
R4737	1-216-833-11	METAL CHIP 10K	5%	1/10W	
R4738	1-216-845-11	METAL CHIP 100K	5%	1/10W	
R4739	1-216-825-11	METAL CHIP 2.2K	5%	1/10W	
R4740	1-216-825-11	METAL CHIP 2.2K	5%	1/10W	
R4744	1-216-841-11	METAL CHIP 47K	5%	1/10W	
R4746	1-216-841-11	METAL CHIP 47K	5%	1/10W	
R4747	1-216-653-11	METAL CHIP 1.2K	0.5%	1/10W	
R4748	1-216-821-11	METAL CHIP 1K	5%	1/10W	
R4749	1-216-688-11	METAL CHIP 36K	0.5%	1/10W	
R4750	1-216-653-11	METAL CHIP 1.2K	0.5%	1/10W	
R4751	1-216-688-11	METAL CHIP 36K	0.5%	1/10W	
R4752	1-216-845-11	METAL CHIP 100K	5%	1/10W	
R4753	1-216-833-11	METAL CHIP 10K	5%	1/10W	
R4754	1-216-077-91	RES-CHIP 15K	5%	1/10W	
R4755	1-216-864-11	SHORT CHIP 0			
R4756	1-216-841-11	METAL CHIP 47K	5%	1/10W	
R4757	1-216-841-11	METAL CHIP 47K	5%	1/10W	
R4758	1-216-834-11	METAL CHIP 12K	5%	1/10W	
R4759	1-216-809-11	METAL CHIP 100	5%	1/10W	
R4760	1-216-821-11	METAL CHIP 1K	5%	1/10W	
R4761	1-216-821-11	METAL CHIP 1K	5%	1/10W	
R4762	1-216-841-11	METAL CHIP 47K	5%	1/10W	
R4763	1-216-833-11	METAL CHIP 10K	5%	1/10W	
R4764	1-215-857-71	METAL OXIDE 10	5%	1W	
R4765	1-215-857-71	METAL OXIDE 10	5%	1W	
R4766	1-216-833-11	METAL CHIP 10K	5%	1/10W	
R4768	1-216-864-11	SHORT CHIP 0			
R4771	1-216-841-11	METAL CHIP 47K	5%	1/10W	
R4772	1-216-830-11	METAL CHIP 5.6K	5%	1/10W	

REF. NO.	PART NO.	DESCRIPTION	REMARK		
R4773	1-216-816-11	METAL CHIP 390	5%	1/10W	
R4774	1-216-864-11	SHORT CHIP 0			
R4775	1-216-822-11	METAL CHIP 1.2K	5%	1/10W	
R4776	1-216-841-11	METAL CHIP 47K	5%	1/10W	
R4777	1-216-848-11	METAL CHIP 180K	5%	1/10W	
R4778	1-216-830-11	METAL CHIP 5.6K	5%	1/10W	
R4779	1-216-816-11	METAL CHIP 390	5%	1/10W	
R4780	1-216-848-11	METAL CHIP 180K	5%	1/10W	
R4781	1-216-827-11	METAL CHIP 3.3K	5%	1/10W	
R4782	1-216-864-11	SHORT CHIP 0			
R4783	1-216-827-11	METAL CHIP 3.3K	5%	1/10W	
R4784	1-216-864-11	SHORT CHIP 0			
R4785	1-216-829-11	METAL CHIP 4.7K	5%	1/10W	
R4786	1-216-829-11	METAL CHIP 4.7K	5%	1/10W	
R4787	1-216-845-11	METAL CHIP 100K	5%	1/10W	
R4788	1-216-845-11	METAL CHIP 100K	5%	1/10W	
R4789	1-216-841-11	METAL CHIP 47K	5%	1/10W	
R4790	1-216-841-11	METAL CHIP 47K	5%	1/10W	
R4791	1-216-841-11	METAL CHIP 47K	5%	1/10W	
R4792	1-216-841-11	METAL CHIP 47K	5%	1/10W	
R4793	1-216-827-11	METAL CHIP 3.3K	5%	1/10W	
R4794	1-216-827-11	METAL CHIP 3.3K	5%	1/10W	
R4795	1-216-864-11	SHORT CHIP 0			
R4796	1-216-864-11	SHORT CHIP 0			
R4799	1-216-864-11	SHORT CHIP 0			
R4800	1-216-864-11	SHORT CHIP 0			
R4801	1-216-864-11	SHORT CHIP 0			
R4802	1-216-864-11	SHORT CHIP 0			
R4827	1-216-864-11	SHORT CHIP 0			
R4828	1-216-864-11	SHORT CHIP 0			
R4829	1-216-864-11	SHORT CHIP 0			

*	A-1302-273-A	F BOARD, COMPLETE			

	1-533-223-11	FUSE HOLDER	0A	0V	
< CAPACITOR >					
Δ	C1961	1-119-888-51 CERAMIC	2200pF	20%	250V
Δ	C1962	1-119-888-51 CERAMIC	2200pF	20%	250V
Δ	C1964	1-104-708-11 MYLAR	0.47 μ F	20%	250V
< CONNECTOR >					
Δ	*CN1901	1-580-843-11 PIN, CONNECTOR (POWER)			
	*CN1902	1-537-711-11 TAB, FASTEN (PCB)			
	CN1906	1-695-915-11 TAB (CONTACT)			
	*CN1907	1-580-689-11 PIN, CONNECTOR (PC BOARD) 4P			
	*CN1908	1-537-711-11 TAB, FASTEN (PCB)			
< FUSE >					
Δ	F1901	1-576-193-11 FUSE	6.3A	125V	
< RESISTOR >					
Δ	R1953	1-219-759-11 METAL	1M	5%	1/2W
Δ	R1962	1-218-265-11 METAL	8.2M	5%	1W
< TRANSFORMER >					
Δ	T1905	1-435-617-11 TRANSFORMER, LINE FILTER			

Les composants identifiés par une trame et une marque Δ sont critiques pour la sécurité. Ne les remplacer que par une pièce portant le numéro spécifique.

The components identified by shading and mark Δ are critical for safety. Replace only with part number specified.

KF-42WE610/50WE610/60WE610

RM-Y913

RM-Y913

RM-Y913

F

G1

REF. NO.	PART NO.	DESCRIPTION	REMARK
Δ T1906	1-435-617-11	TRANSFORMER, LINE FILTER	

*	A-1302-272-A	G1 BOARD, COMPLETE	*****
*	4-374-846-01	COVER, CAPACITOR, CAP TYPE	
	4-382-854-01	SCREW (M3X8), P, SW (+)	
< CAPACITOR >			
	C1601	1-126-967-11 ELECT	47 μ F 20% 50V
	C1602	1-162-962-11 CERAMIC CHIP	470pF 10% 50V
	C1603	1-107-652-11 ELECT	10 μ F 20% 250V
Δ	C1604	1-161-830-00 CERAMIC	0.0047 μ F 99% 500V
Δ	C1605	1-161-830-00 CERAMIC	0.0047 μ F 99% 500V
	C1606	1-164-361-11 CERAMIC CHIP	0.047 μ F 25V
Δ	C1607	1-161-830-00 CERAMIC	0.0047 μ F 99% 500V
Δ	C1608	1-161-830-00 CERAMIC	0.0047 μ F 99% 500V
	C1609	1-162-970-11 CERAMIC CHIP	0.01 μ F 10% 25V
	C1610	1-162-964-11 CERAMIC CHIP	0.001 μ F 10% 50V
Δ	C1611	1-137-750-11 ELECT	1500 μ F 20% 250V
Δ	C1612	1-137-750-11 ELECT	1500 μ F 20% 250V
	C1613	1-126-967-11 ELECT	47 μ F 20% 50V
	C1614	1-162-974-11 CERAMIC CHIP	0.01 μ F 50V
	C1615	1-126-967-11 ELECT	47 μ F 20% 50V
	C1616	1-119-876-11 MYLAR	0.01 μ F 10% 400V
	C1617	1-126-965-11 ELECT	22 μ F 20% 50V
	C1618	1-136-165-00 FILM	0.1 μ F 5% 50V
	C1620	1-126-960-11 ELECT	1 μ F 20% 50V
	C1621	1-126-940-11 ELECT	330 μ F 20% 25V
	C1622	1-126-961-11 ELECT	2.2 μ F 20% 50V
	C1623	1-136-479-11 FILM	0.001 μ F 2% 100V
	C1624	1-126-962-11 ELECT	3.3 μ F 20% 50V
	C1625	1-164-156-11 CERAMIC CHIP	0.1 μ F 25V
	C1626	1-126-939-11 ELECT	10000 μ F 20% 16V
	C1627	1-125-969-91 CERAMIC	680pF 10% 1KV
	C1628	1-125-969-91 CERAMIC	680pF 10% 1KV
	C1629	1-165-953-11 FILM	47000pF 3% 800V
	C1630	1-164-156-11 CERAMIC CHIP	0.1 μ F 25V
	C1631	1-162-974-11 CERAMIC CHIP	0.01 μ F 50V
	C1632	1-102-244-00 CERAMIC	220pF 10% 500V
	C1633	1-102-244-00 CERAMIC	220pF 10% 500V
	C1634	1-102-244-00 CERAMIC	220pF 10% 500V
	C1635	1-102-244-00 CERAMIC	220pF 10% 500V
	C1636	1-128-955-31 ELECT	2200 μ F 20% 25V
	C1637	1-128-955-31 ELECT	2200 μ F 20% 25V
	C1638	1-100-309-21 ELECT CHIP	22 μ F 20% 25V
	C1639	1-164-156-11 CERAMIC CHIP	0.1 μ F 25V
	C1640	1-162-970-11 CERAMIC CHIP	0.01 μ F 10% 25V
	C1641	1-128-582-11 ELECT	10 μ F 20% 100V
	C1642	1-131-976-11 ELECT	820 μ F 20% 25V
	C1643	1-131-976-11 ELECT	820 μ F 20% 25V
	C1644	1-131-976-11 ELECT	820 μ F 20% 25V
	C1646	1-165-908-11 CERAMIC CHIP	1 μ F 10% 10V
	C1647	1-165-908-11 CERAMIC CHIP	1 μ F 10% 10V
	C1649	1-115-416-11 CERAMIC CHIP	0.001 μ F 5% 25V
	C1650	1-115-416-11 CERAMIC CHIP	0.001 μ F 5% 25V
	C1651	1-165-176-11 CERAMIC CHIP	0.047 μ F 10% 16V
	C1653	1-165-681-21 ELECT CHIP	180 μ F 20% 16V
	C1654	1-126-947-11 ELECT	47 μ F 20% 35V
	C1655	1-162-970-11 CERAMIC CHIP	0.01 μ F 10% 25V
	C1656	1-162-970-11 CERAMIC CHIP	0.01 μ F 10% 25V
	C1657	1-162-964-11 CERAMIC CHIP	0.001 μ F 10% 50V

REF. NO.	PART NO.	DESCRIPTION	REMARK
	C1658	1-162-964-11 CERAMIC CHIP	0.001 μ F 10% 50V
	C1659	1-137-194-81 FILM	0.47 μ F 5% 50V
Δ	C1660	1-104-708-11 MYLAR	0.47 μ F 20% 250V
	C1661	1-162-970-11 CERAMIC CHIP	0.01 μ F 10% 25V
	C1665	1-100-309-21 ELECT CHIP	22 μ F 20% 25V
	C1670	1-100-714-11 ELECT	100 μ F 20% 400V
	C1671	1-100-714-11 ELECT	100 μ F 20% 400V
	C1672	1-161-830-00 CERAMIC	0.0047 μ F 500V
	C1673	1-131-976-11 ELECT	820 μ F 20% 25V
	C1674	1-100-309-21 ELECT CHIP	22 μ F 20% 25V
	C1675	1-164-156-11 CERAMIC CHIP	0.1 μ F 25V
Δ	C1676	1-161-964-91 CERAMIC	0.0047 μ F 250V
Δ	C1677	1-161-964-91 CERAMIC	0.0047 μ F 250V
Δ	C1678	1-161-964-91 CERAMIC	0.0047 μ F 250V
Δ	C1679	1-161-964-91 CERAMIC	0.0047 μ F 250V
	C1680	1-164-156-11 CERAMIC CHIP	0.1 μ F 25V
	C1681	1-110-563-11 CERAMIC CHIP	0.068 μ F 10% 16V
	C1682	1-164-156-11 CERAMIC CHIP	0.1 μ F 25V
	C1683	1-164-156-11 CERAMIC CHIP	0.1 μ F 25V
	C1684	1-164-156-11 CERAMIC CHIP	0.1 μ F 25V
	C1685	1-100-309-21 ELECT CHIP	22 μ F 20% 25V
	C1686	1-164-156-11 CERAMIC CHIP	0.1 μ F 25V
	C1687	1-164-156-11 CERAMIC CHIP	0.1 μ F 25V
	C1688	1-164-156-11 CERAMIC CHIP	0.1 μ F 25V
	C1689	1-165-677-21 ELECT CHIP	330 μ F 20% 10V
	C1690	1-104-665-11 ELECT	100 μ F 20% 25V
	C1691	1-126-927-11 ELECT	2200 μ F 20% 10V
	C1692	1-104-665-11 ELECT	100 μ F 20% 25V
	C1693	1-126-926-11 ELECT	1000 μ F 20% 10V
	C1694	1-104-665-11 ELECT	100 μ F 20% 25V
	C1695	1-126-767-11 ELECT	1000 μ F 20% 16V
	C1696	1-126-934-11 ELECT	220 μ F 20% 16V
	C1697	1-162-970-11 CERAMIC CHIP	0.01 μ F 10% 25V
	C1698	1-162-970-11 CERAMIC CHIP	0.01 μ F 10% 25V
	C1709	1-126-942-61 ELECT	1000 μ F 20% 25V
< CONNECTOR >			
*	CN1602	1-691-960-21 PIN, CONNECTOR (PC BOARD) 3P	
*	CN1603	1-793-923-11 CONNECTOR, DIN (PLUG) 64P	
	CN1604	1-764-612-11 CONNECTOR, BOARD TO BOARD 10P	
*	CN1605	1-564-511-61 PLUG, CONNECTOR 8P	
*	CN1609	1-580-689-11 PIN, CONNECTOR (PC BOARD) 4P	
	CN1611	1-695-915-11 TAB (CONTACT)	
< DIODE >			
Δ	D1601	8-719-077-76 DIODE D2SB60A-F04	
Δ	D1602	8-719-022-99 DIODE D6SB60L	
	D1603	8-719-037-39 DIODE RD18SB2-T1	
	D1604	8-719-404-50 DIODE MA111-TX	
	D1605	8-719-948-45 DIODE ERA22-08	
	D1606	8-719-033-53 DIODE RD6.8SB2-T1	
	D1607	8-719-979-64 DIODE μ F4005PKG23	
	D1608	8-719-064-49 DIODE D4SBL40	
	D1609	8-719-063-73 DIODE D1NL20U-TR	
	D1610	8-719-510-48 DIODE D1N20R	
	D1612	8-719-404-50 DIODE MA111-TX	
	D1613	8-719-063-73 DIODE D1NL20U-TR	
	D1614	8-719-510-02 DIODE D1NS4	
	D1618	8-719-404-50 DIODE MA111-TX	
	D1619	8-719-037-39 DIODE RD18SB2-T1	
	D1620	8-719-064-40 DIODE DE5SC3ML-TA	

Les composants identifiés par une trame et une marque Δ sont critiques pour la sécurité. Ne les remplacer que par une pièce portant le numéro spécifié.

The components identified by shading and mark Δ are critical for safety. Replace only with part number specified.

KF-42WE610/50WE610/60WE610

RM-Y913

RM-Y913

RM-Y913

G1

REF. NO.	PART NO.	DESCRIPTION	REMARK
D1621	8-719-064-40	DIODE DE5SC3ML-TA	
D1622	8-719-063-73	DIODE D1NL20U-TR	
D1623	8-719-510-09	DIODE D10SC6M	
D1624	8-719-060-89	DIODE D4SBS6-F	
D1625	8-719-510-09	DIODE D10SC6M	
D1626	8-719-056-23	DIODE MA2S111-(K8).SO	
D1628	8-719-404-50	DIODE MA111-TX	
D1629	8-719-404-50	DIODE MA111-TX	
D1630	8-719-404-50	DIODE MA111-TX	
D1631	8-719-404-50	DIODE MA111-TX	
D1632	8-719-404-50	DIODE MA111-TX	
D1633	8-719-068-00	DIODE ERC04-06SE	
D1634	8-719-068-00	DIODE ERC04-06SE	
D1635	8-719-404-50	DIODE MA111-TX	
D1636	8-719-404-50	DIODE MA111-TX	
D1637	8-719-404-50	DIODE MA111-TX	
D1638	8-719-404-50	DIODE MA111-TX	
D1639	8-719-037-39	DIODE RD18SB2-T1	
D1640	8-719-404-50	DIODE MA111-TX	
D1641	8-719-158-49	DIODE RD12SB2-T1	
D1642	8-719-404-50	DIODE MA111-TX	
D1643	8-719-037-07	DIODE RD7.5SB2-T1	
D1644	8-719-063-73	DIODE D1NL20U-TR	
D1645	8-719-056-23	DIODE MA2S111-(K8).SO	
D1646	8-719-404-50	DIODE MA111-TX	
D1647	8-719-404-50	DIODE MA111-TX	
D1648	8-719-948-45	DIODE ERA22-08	
D1649	8-719-063-73	DIODE D1NL20U-TR	
< FUSE >			
Δ F1602	1-533-272-21	FUSE	4A 125V
Δ F1603	1-533-272-21	FUSE	4A 125V
< FERRITE BEAD >			
FB1601	1-414-229-11	FERRITE	0 μ H
FB1602	1-469-869-21	FERRITE	0 μ H
FB1603	1-469-869-21	FERRITE	0 μ H
< IC >			
Δ IC1601	6-703-355-01	IC MCZ3001DA	
IC1602	8-759-198-31	IC μ PC1093J-1-T	
Δ IC1603	6-704-852-01	IC MD3222N	
IC1604	6-704-852-01	IC MD3222N	
IC1606	8-759-284-06	IC PQ30RV31	
IC1607	8-759-098-24	IC PQ30RV11	
IC1608	8-759-520-49	IC PQ30RV21	
< COIL >			
L1604	1-412-537-31	INDUCTOR	100 μ H
L1605	1-412-537-31	INDUCTOR	100 μ H
L1606	1-424-789-41	INDUCTOR	10 μ H
L1607	1-412-525-31	INDUCTOR	10 μ H
L1608	1-412-525-31	INDUCTOR	10 μ H
L1609	1-424-789-41	INDUCTOR	10 μ H
L1610	1-406-974-41	INDUCTOR	33 μ H
L1611	1-406-974-41	INDUCTOR	33 μ H
L1612	1-412-537-31	INDUCTOR	100 μ H
L1616	1-406-983-11	INDUCTOR	1mH

REF. NO.	PART NO.	DESCRIPTION	REMARK
< PHOTOCOUPLER >			
Δ PH16018	749-924-35	PHOTOCOUPLER	ON3171-R
Δ PH16028	749-924-35	PHOTOCOUPLER	ON3171-R
< IC LINK >			
Δ PS1601	1-576-390-91	IC LINK	2.5A 50V
Δ PS1602	1-576-390-91	IC LINK	2.5A 50V
< TRANSISTOR >			
Q1601	8-729-046-40	TRANSISTOR	2SK2663
Q1602	8-729-422-27	TRANSISTOR	2SD601A-Q
Q1603	8-729-422-27	TRANSISTOR	2SD601A-Q
Q1604	8-729-216-22	TRANSISTOR	2SA1162-G
Q1605	8-729-422-27	TRANSISTOR	2SD601A-Q
Δ Q1606	8-729-052-32	TRANSISTOR	IRFIB7N50A-LF31
Δ Q1607	8-729-052-32	TRANSISTOR	IRFIB7N50A-LF31
< RESISTOR >			
Δ R1601	1-260-302-71	CARBON	6.8 5% 1/2W
R1603	1-216-819-11	METAL CHIP	680 5% 1/10W
R1604	1-240-205-91	METAL	22M 5% 1/2W
R1605	1-216-801-11	METAL CHIP	22 5% 1/10W
Δ R1606	1-249-389-91	CARBON	4.7 5% 1/4W
Δ R1607	1-211-795-71	FUSIBLE	470 5% 1/4W
R1608	1-216-833-11	METAL CHIP	10K 5% 1/10W
R1609	1-216-817-11	METAL CHIP	470 5% 1/10W
R1610	1-260-131-11	CARBON	470K 5% 1/2W
R1611	1-260-131-11	CARBON	470K 5% 1/2W
R1612	1-245-478-21	METAL	470K 1% 1/4W
Δ R1613	1-202-933-61	FUSIBLE	0.1 10% 1/2W
R1614	1-245-471-21	METAL	240K 1% 1/4W
Δ R1615	1-249-377-91	CARBON	0.47 5% 1/4W
R1616	1-249-393-11	CARBON	10 5% 1/4W
R1618	1-216-361-00	METAL OXIDE	0.22 5% 2W
Δ R1619	1-220-778-21	FUSIBLE	0.1 10% 1/2W
R1620	1-216-833-11	METAL CHIP	10K 5% 1/10W
R1621	1-216-829-11	METAL CHIP	4.7K 5% 1/10W
R1622	1-216-833-11	METAL CHIP	10K 5% 1/10W
R1623	1-216-821-11	METAL CHIP	1K 5% 1/10W
R1624	1-245-471-21	METAL	240K 1% 1/4W
R1625	1-245-471-21	METAL	240K 1% 1/4W
R1626	1-245-472-21	METAL	270K 1% 1/4W
R1627	1-249-403-11	CARBON	68 5% 1/4W
R1628	1-218-720-11	METAL CHIP	15K 0.5% 1/10W
R1629	1-218-715-11	METAL CHIP	9.1K 0.5% 1/10W
R1630	1-216-833-11	METAL CHIP	10K 5% 1/10W
R1631	1-216-833-11	METAL CHIP	10K 5% 1/10W
R1632	1-249-393-11	CARBON	10 5% 1/4W
R1633	1-216-833-11	METAL CHIP	10K 5% 1/10W
R1634	1-249-393-11	CARBON	10 5% 1/4W
R1635	1-216-833-11	METAL CHIP	10K 5% 1/10W
R1638	1-216-361-00	METAL OXIDE	0.22 5% 2W
R1639	1-218-730-11	METAL CHIP	39K 0.5% 1/10W
R1640	1-216-350-11	METAL OXIDE	1.2 5% 1W
R1641	1-216-821-11	METAL CHIP	1K 5% 1/10W
R1642	1-216-825-11	METAL CHIP	2.2K 5% 1/10W
R1643	1-218-712-11	METAL CHIP	6.8K 0.5% 1/10W
R1644	1-218-668-11	METAL CHIP	100 0.5% 1/10W
R1645	1-218-680-11	METAL CHIP	330 0.5% 1/10W
R1646	1-216-825-11	METAL CHIP	2.2K 5% 1/10W

Les composants identifiés par une trame et une marque Δ sont critiques pour la sécurité. Ne les remplacer que par une pièce portant le numéro spécifié.

The components identified by shading and mark Δ are critical for safety. Replace only with part number specified.

KF-42WE610/50WE610/60WE610

RM-Y913

RM-Y913

RM-Y913

G1

H1

H2

REF. NO.	PART NO.	DESCRIPTION	REMARK
R1647	1-216-817-11	METAL CHIP	470 5% 1/10W
R1648	1-216-841-11	METAL CHIP	47K 5% 1/10W
R1649	1-216-821-11	METAL CHIP	1K 5% 1/10W
R1650	1-218-692-11	METAL CHIP	1K 0.5% 1/10W
R1651	1-260-288-11	CARBON	0.47 5% 1/2W
Δ R1652	1-202-962-11	METAL	3.3 5% 10W
Δ R1654	1-260-288-11	CARBON	0.47 5% 1/2W
Δ R1655	1-260-288-11	CARBON	0.47 5% 1/2W
R1656	1-215-904-11	METAL OXIDE	100K 5% 2W
R1657	1-215-904-11	METAL OXIDE	100K 5% 2W
R1658	1-216-845-11	METAL CHIP	100K 5% 1/10W
R1659	1-216-864-11	SHORT CHIP	0
R1660	1-218-689-11	METAL CHIP	750 0.5% 1/10W
R1661	1-218-718-11	METAL CHIP	12K 0.5% 1/10W
R1664	1-216-864-11	SHORT CHIP	0
R1665	1-216-864-11	SHORT CHIP	0
R1666	1-218-692-11	METAL CHIP	1K 0.5% 1/10W
R1671	1-216-845-11	METAL CHIP	100K 5% 1/10W
R1672	1-216-864-11	SHORT CHIP	0
R1673	1-216-864-11	SHORT CHIP	0
R1674	1-216-864-11	SHORT CHIP	0
R1675	1-216-821-11	METAL CHIP	1K 5% 1/10W
R1676	1-216-864-11	SHORT CHIP	0
R1677	1-218-680-11	METAL CHIP	330 0.5% 1/10W
R1678	1-218-692-11	METAL CHIP	1K 0.5% 1/10W
R1679	1-218-696-11	METAL CHIP	1.5K 0.5% 1/10W
R1680	1-218-684-11	METAL CHIP	470 0.5% 1/10W
R1681	1-218-700-11	METAL CHIP	2.2K 0.5% 1/10W
R1682	1-218-692-11	METAL CHIP	1K 0.5% 1/10W
R1683	1-218-692-11	METAL CHIP	1K 0.5% 1/10W
R1684	1-218-712-11	METAL CHIP	6.8K 0.5% 1/10W
R1685	1-218-742-11	METAL CHIP	120K 0.5% 1/10W
R1686	1-216-839-11	METAL CHIP	33K 5% 1/10W
R1687	1-216-833-11	METAL CHIP	10K 5% 1/10W
R1688	1-218-712-11	METAL CHIP	6.8K 0.5% 1/10W
R1689	1-216-829-11	METAL CHIP	4.7K 5% 1/10W
R1690	1-216-821-11	METAL CHIP	1K 5% 1/10W
R1700	1-216-829-11	METAL CHIP	4.7K 5% 1/10W
R1701	1-260-328-11	CARBON	1K 5% 1/2W
R1702	1-249-401-11	CARBON	47 5% 1/4W
R1706	1-216-864-11	SHORT CHIP	0
R1707	1-216-864-11	SHORT CHIP	0
R1708	1-216-864-11	SHORT CHIP	0
R1709	1-216-864-11	SHORT CHIP	0
< RELAY >			
Δ RY1601	1-755-407-11	RELAY (AC POWER)	
RY1602	1-755-407-11	RELAY (AC POWER)	
< TRANSFORMER >			
Δ T1601	1-431-852-11	TRANSFORMER, CONVERTER (SRT)	
Δ T1603	1-443-102-11	CONVERTER TRANSFORMER (PIT)	
< THERMISTOR >			
TH1601	1-803-586-41	THERMISTOR	
< VARISTOR >			
Δ VD1601	1-804-992-21	VARISTOR	

REF. NO.	PART NO.	DESCRIPTION	REMARK
*	A-1405-438-B	H1 BOARD, COMPLETE	*****
< CAPACITOR >			
C171	1-162-970-11	CERAMIC CHIP	0.01 μ F 10% 25V
C172	1-164-156-11	CERAMIC CHIP	0.1 μ F 25V
C173	1-127-692-11	CERAMIC CHIP	10 μ F 10% 16V
< CONNECTOR >			
CN171	1-565-877-11	PIN, CONNECTOR (PC BOARD) 5P	
< IC >			
IC171	8-742-134-01	HYB IC SBX1981-51P	
< RESISTOR >			
R171	1-218-684-11	METAL CHIP	470 0.5% 1/10W
R172	1-218-688-11	METAL CHIP	680 0.5% 1/10W
R173	1-218-692-11	METAL CHIP	1K 0.5% 1/10W
R174	1-218-700-11	METAL CHIP	2.2K 0.5% 1/10W
R175	1-216-805-11	METAL CHIP	47 5% 1/10W
R176	1-216-837-11	METAL CHIP	22K 5% 1/10W
< SWITCH >			
S171	1-762-196-21	SWITCH, TACT (CHANNEL +)	
S172	1-762-196-21	SWITCH, TACT (CHANNEL -)	
S173	1-762-196-21	SWITCH, TACT (VOLUME +)	
S174	1-762-196-21	SWITCH, TACT (VOLUME -)	
S175	1-762-196-21	SWITCH, TACT (TV/VIDEO)	

*	A-1405-436-A	H2 BOARD, COMPLETE	*****
< CAPACITOR >			
C4501	1-164-156-11	CERAMIC CHIP	0.1 μ F 25V
C4503	1-162-974-11	CERAMIC CHIP	0.01 μ F 50V
C4505	1-162-974-11	CERAMIC CHIP	0.01 μ F 50V
C4506	1-162-974-11	CERAMIC CHIP	0.01 μ F 50V
C4507	1-162-974-11	CERAMIC CHIP	0.01 μ F 50V
C4508	1-162-974-11	CERAMIC CHIP	0.01 μ F 50V
< CONNECTOR >			
CN4502	1-565-880-11	PIN, CONNECTOR (PC BOARD) 8P	
< DIODE >			
D4503	8-719-053-43	DIODE SLR-325VCT31	
D4504	8-719-064-11	DIODE SPR-325MVW	
D4510	8-719-053-43	DIODE SLR-325VCT31	
< TRANSISTOR >			
Q4503	8-729-422-27	TRANSISTOR 2SD601A-Q	
Q4504	8-729-422-27	TRANSISTOR 2SD601A-Q	
Q4508	1-801-806-11	TRANSISTOR DTC144EKA	
Q4509	1-801-806-11	TRANSISTOR DTC144EKA	
Q4510	8-729-027-23	TRANSISTOR DTA114EKA-T146	



REF. NO.	PART NO.	DESCRIPTION	REMARK		
Q4511	8-729-027-23	TRANSISTOR DTA114EKA-T146			
		< RESISTOR >			
R4502	1-216-815-11	METAL CHIP	330	5%	1/10W
R4506	1-216-833-11	METAL CHIP	10K	5%	1/10W
R4509	1-216-815-11	METAL CHIP	330	5%	1/10W
R4512	1-216-815-11	METAL CHIP	330	5%	1/10W
R4513	1-216-833-11	METAL CHIP	10K	5%	1/10W
R4514	1-216-864-11	SHORT CHIP	0		
R4515	1-216-864-11	SHORT CHIP	0		
R4516	1-216-815-11	METAL CHIP	330	5%	1/10W
R4517	1-216-833-11	METAL CHIP	10K	5%	1/10W
R4518	1-216-833-11	METAL CHIP	10K	5%	1/10W
		< SWITCH >			
S4501	1-572-198-11	SWITCH, KEYBOARD (POWER)			

*	A-1405-433-A	H3 BOARD, COMPLETE	*****		
		< CAPACITOR >			
C44	1-162-915-11	CERAMIC CHIP	10pF	0.50pF	50V
C45	1-162-915-11	CERAMIC CHIP	10pF	0.50pF	50V
C50	1-126-964-11	ELECT	10μF	20%	50V
C51	1-126-964-11	ELECT	10μF	20%	50V
C52	1-126-964-11	ELECT	10μF	20%	50V
C53	1-126-964-11	ELECT	10μF	20%	50V
C58	1-126-933-11	ELECT	100μF	20%	16V
C59	1-164-156-11	CERAMIC CHIP	0.1μF		25V
C70	1-162-974-11	CERAMIC CHIP	0.01μF		50V
C72	1-115-156-11	CERAMIC CHIP	1μF		10V
C77	1-162-970-11	CERAMIC CHIP	0.01μF	10%	25V
		< CONNECTOR >			
CN43	1-564-528-11	PLUG, CONNECTOR 13P			
* CN44	1-564-519-11	PLUG, CONNECTOR 4P			
CN45	1-695-915-11	TAB (CONTACT)			
		< DIODE >			
D40	8-719-977-28	DIODE DTZ10B			
D49	8-719-977-28	DIODE DTZ10B			
D50	8-719-977-28	DIODE DTZ10B			
D51	8-719-977-28	DIODE DTZ10B			
D52	8-719-977-28	DIODE DTZ10B			
		< IC >			
IC41	8-759-442-07	IC LM75CIMX-5			
		< JACK >			
J40	1-770-053-12	TERMINAL BLOCK, S (LIGHT ANGLE) (VIDEO 2 IN)			
		< RESISTOR >			
R41	1-216-864-11	SHORT CHIP	0		

REF. NO.	PART NO.	DESCRIPTION	REMARK		
R42	1-216-864-11	SHORT CHIP	0		
R43	1-216-864-11	SHORT CHIP	0		
R44	1-216-864-11	SHORT CHIP	0		
R45	1-216-864-11	SHORT CHIP	0		
R46	1-216-849-11	METAL CHIP	220K	5%	1/10W
R47	1-216-849-11	METAL CHIP	220K	5%	1/10W
R48	1-218-665-11	METAL CHIP	75	0.5%	1/10W
R49	1-216-801-11	METAL CHIP	22	5%	1/10W
R50	1-218-665-11	METAL CHIP	75	0.5%	1/10W
R51	1-216-801-11	METAL CHIP	22	5%	1/10W
R54	1-216-864-11	SHORT CHIP	0		
R55	1-216-864-11	SHORT CHIP	0		
R57	1-216-864-11	SHORT CHIP	0		
R75	1-216-821-11	METAL CHIP	1K	5%	1/10W
R89	1-218-665-11	METAL CHIP	75	0.5%	1/10W
		< VARISTOR >			
VD40	1-803-974-21	VARISTOR, CHIP (1608)			

*	A-1302-276-A	HM BOARD, COMPLETE	*****		
		< CAPACITOR >			
C1301	1-164-156-11	CERAMIC CHIP	0.1μF		25V
C1302	1-163-021-91	CERAMIC CHIP	0.01μF	10%	50V
C1305	1-107-826-11	CERAMIC CHIP	0.1μF	10%	16V
C1308	1-162-970-11	CERAMIC CHIP	0.01μF	10%	25V
C1309	1-107-826-11	CERAMIC CHIP	0.1μF	10%	16V
C1310	1-126-390-11	ELECT CHIP	22μF	20%	6.3V
C1311	1-137-710-11	CERAMIC CHIP	10μF	20%	6.3V
		< CONNECTOR >			
*CN1301	1-793-807-21	PIN, CONNECTOR (WITH PWB) 20P			
*CN1303	1-564-507-11	PLUG, CONNECTOR 4P			
*CN1304	1-816-402-12	CONNECTOR, MEMORY STICK			
		< DIODE >			
D1301	8-719-024-77	DIODE HN1D03FU-TE85R			
D1303	8-719-024-77	DIODE HN1D03FU-TE85R			
D1305	8-719-024-77	DIODE HN1D03FU-TE85R			
D1307	8-719-024-77	DIODE HN1D03FU-TE85R			
D1309	8-719-024-77	DIODE HN1D03FU-TE85R			
D1311	6-500-348-01	DIODE KPA-3010ID-GEC			
D1313	8-719-024-77	DIODE HN1D03FU-TE85R			
D1315	8-719-024-77	DIODE HN1D03FU-TE85R			
D1316	8-719-158-02	DIODE RD3.9SB2			
		< FERRITE BEAD >			
FB1301	1-414-921-11	FERRITE	0μH		
FB1303	1-469-152-11	FERRITE	0μH		
FB1304	1-469-152-11	FERRITE	0μH		
		< IC >			
IC1301	6-702-952-01	IC SN65LVDT14PWR			
IC1303	8-759-698-08	IC SN74CBTLV1G125DCKR			



REF. NO.	PART NO.	DESCRIPTION	REMARK
		< COIL >	
L1302	1-469-555-21	INDUCTOR 10μH	
		< TRANSISTOR >	
Q1301	8-729-140-63	TRANSISTOR 2SA1611T1-M5M6	
Q1302	8-729-029-14	TRANSISTOR DTC144EUA-T106	
Q1304	8-729-216-22	TRANSISTOR 2SA1162-G	
		< RESISTOR >	
R1303	1-216-864-11	SHORT CHIP 0	
R1305	1-216-864-11	SHORT CHIP 0	
R1307	1-216-864-11	SHORT CHIP 0	
R1309	1-216-864-11	SHORT CHIP 0	
R1311	1-216-864-11	SHORT CHIP 0	
R1315	1-216-864-11	SHORT CHIP 0	
R1317	1-216-864-11	SHORT CHIP 0	
R1321	1-216-864-11	SHORT CHIP 0	
R1323	1-216-864-11	SHORT CHIP 0	
R1325	1-216-864-11	SHORT CHIP 0	
R1327	1-216-809-11	METAL CHIP 100 5% 1/10W	
R1328	1-216-821-11	METAL CHIP 1K 5% 1/10W	
R1329	1-216-833-11	METAL CHIP 10K 5% 1/10W	
R1330	1-216-801-11	METAL CHIP 22 5% 1/10W	
R1331	1-216-801-11	METAL CHIP 22 5% 1/10W	
R1332	1-218-692-11	METAL CHIP 1K 0.5% 1/10W	
R1333	1-216-801-11	METAL CHIP 22 5% 1/10W	
R1336	1-216-845-11	METAL CHIP 100K 5% 1/10W	
R1337	1-218-871-11	METAL CHIP 10K 0.5% 1/10W	
R1340	1-216-837-11	METAL CHIP 22K 5% 1/10W	

*	A-1405-434-A	T BOARD, COMPLETE *****	
		< CONNECTOR >	
*CN3999	1-564-518-11	PLUG, CONNECTOR 3P	
		< SWITCH >	
S3999	1-570-245-11	SWITCH, MICRO (DOOR)	

*	A-1302-270-A	U BOARD, COMPLETE *****	
		< CAPACITOR >	
C9401	1-162-974-11	CERAMIC CHIP 0.01μF 50V	
C9402	1-164-346-11	CERAMIC CHIP 1μF 16V	
C9403	1-164-346-11	CERAMIC CHIP 1μF 16V	
C9404	1-107-714-11	ELECT 10μF 20% 50V	
C9405	1-107-714-11	ELECT 10μF 20% 50V	
C9407	1-126-933-11	ELECT 100μF 20% 16V	
C9410	1-162-966-11	CERAMIC CHIP 0.0022μF 10% 50V	
C9411	1-162-966-11	CERAMIC CHIP 0.0022μF 10% 50V	
C9412	1-126-964-11	ELECT 10μF 20% 50V	
C9413	1-125-837-91	CERAMIC CHIP 1μF 10% 6.3V	
C9414	1-125-837-91	CERAMIC CHIP 1μF 10% 6.3V	
C9415	1-162-966-11	CERAMIC CHIP 0.0022μF 10% 50V	
C9416	1-126-964-11	ELECT 10μF 20% 50V	

REF. NO.	PART NO.	DESCRIPTION	REMARK
C9417	1-162-966-11	CERAMIC CHIP 0.0022μF 10% 50V	
C9418	1-125-837-91	CERAMIC CHIP 1μF 10% 6.3V	
C9419	1-162-966-11	CERAMIC CHIP 0.0022μF 10% 50V	
C9420	1-162-966-11	CERAMIC CHIP 0.0022μF 10% 50V	
C9421	1-162-966-11	CERAMIC CHIP 0.0022μF 10% 50V	
C9422	1-162-966-11	CERAMIC CHIP 0.0022μF 10% 50V	
C9424	1-162-966-11	CERAMIC CHIP 0.0022μF 10% 50V	
C9425	1-162-966-11	CERAMIC CHIP 0.0022μF 10% 50V	
C9426	1-126-933-11	ELECT 100μF 20% 16V	
C9429	1-162-966-11	CERAMIC CHIP 0.0022μF 10% 50V	
C9430	1-162-966-11	CERAMIC CHIP 0.0022μF 10% 50V	
C9432	1-162-966-11	CERAMIC CHIP 0.0022μF 10% 50V	
C9433	1-162-966-11	CERAMIC CHIP 0.0022μF 10% 50V	
C9434	1-126-963-11	ELECT 4.7μF 20% 50V	
C9435	1-126-964-11	ELECT 10μF 20% 50V	
C9436	1-126-964-11	ELECT 10μF 20% 50V	
C9437	1-126-964-11	ELECT 10μF 20% 50V	
C9438	1-126-964-11	ELECT 10μF 20% 50V	
C9440	1-126-959-11	ELECT 0.47μF 20% 50V	
C9441	1-126-963-11	ELECT 4.7μF 20% 50V	
C9442	1-126-964-11	ELECT 10μF 20% 50V	
C9443	1-126-959-11	ELECT 0.47μF 20% 50V	
C9444	1-126-964-11	ELECT 10μF 20% 50V	
C9445	1-126-963-11	ELECT 4.7μF 20% 50V	
C9448	1-162-970-11	CERAMIC CHIP 0.01μF 10% 25V	
C9449	1-126-964-11	ELECT 10μF 20% 50V	
C9450	1-126-964-11	ELECT 10μF 20% 50V	
C9451	1-126-963-11	ELECT 4.7μF 20% 50V	
C9453	1-162-970-11	CERAMIC CHIP 0.01μF 10% 25V	
C9454	1-126-963-11	ELECT 4.7μF 20% 50V	
C9455	1-126-964-11	ELECT 10μF 20% 50V	
C9456	1-126-964-11	ELECT 10μF 20% 50V	
C9457	1-127-715-91	CERAMIC CHIP 0.22μF 10% 16V	
C9458	1-126-963-11	ELECT 4.7μF 20% 50V	
C9459	1-107-714-11	ELECT 10μF 20% 50V	
C9460	1-107-714-11	ELECT 10μF 20% 50V	
C9461	1-126-964-11	ELECT 10μF 20% 50V	
C9462	1-126-933-11	ELECT 100μF 20% 16V	
C9463	1-107-714-11	ELECT 10μF 20% 50V	
C9464	1-107-714-11	ELECT 10μF 20% 50V	
C9465	1-126-964-11	ELECT 10μF 20% 50V	
C9466	1-107-826-11	CERAMIC CHIP 0.1μF 10% 16V	
C9467	1-164-360-11	CERAMIC CHIP 0.1μF 16V	
C9468	1-126-964-11	ELECT 10μF 20% 50V	
C9469	1-126-933-11	ELECT 100μF 20% 16V	
C9470	1-164-230-11	CERAMIC CHIP 220pF 5% 50V	
C9471	1-164-230-11	CERAMIC CHIP 220pF 5% 50V	
C9472	1-127-573-11	CERAMIC CHIP 1μF 10% 16V	
C9473	1-127-573-11	CERAMIC CHIP 1μF 10% 16V	
C9474	1-126-964-11	ELECT 10μF 20% 50V	
C9475	1-126-964-11	ELECT 10μF 20% 50V	
C9476	1-126-934-11	ELECT 220μF 20% 16V	
C9482	1-126-964-11	ELECT 10μF 20% 50V	
C9484	1-127-573-11	CERAMIC CHIP 1μF 10% 16V	
C9485	1-126-964-11	ELECT 10μF 20% 50V	
C9486	1-126-964-11	ELECT 10μF 20% 50V	
C9487	1-127-573-11	CERAMIC CHIP 1μF 10% 16V	
C9488	1-125-837-91	CERAMIC CHIP 1μF 10% 6.3V	
C9489	1-125-837-91	CERAMIC CHIP 1μF 10% 6.3V	
C9490	1-107-714-11	ELECT 10μF 20% 50V	
C9491	1-107-714-11	ELECT 10μF 20% 50V	
C9494	1-126-963-11	ELECT 4.7μF 20% 50V	
C9495	1-162-970-11	CERAMIC CHIP 0.01μF 10% 25V	



REF. NO.	PART NO.	DESCRIPTION	REMARK
C9496	1-126-959-11	ELECT	0.47µF 20% 50V
C9499	1-107-714-11	ELECT	10µF 20% 50V
C9500	1-107-714-11	ELECT	10µF 20% 50V
C9518	1-125-837-91	CERAMIC CHIP	1µF 10% 6.3V
C9519	1-164-156-11	CERAMIC CHIP	0.1µF 25V
C9520	1-125-891-11	CERAMIC CHIP	0.47µF 10% 10V
C9521	1-125-891-11	CERAMIC CHIP	0.47µF 10% 10V
C9522	1-126-964-11	ELECT	10µF 20% 50V
C9523	1-126-964-11	ELECT	10µF 20% 50V
C9524	1-125-891-11	CERAMIC CHIP	0.47µF 10% 10V
C9525	1-125-891-11	CERAMIC CHIP	0.47µF 10% 10V
C9526	1-109-982-11	CERAMIC CHIP	1µF 10% 10V
C9527	1-126-935-11	ELECT	470µF 20% 16V
C9528	1-164-156-11	CERAMIC CHIP	0.1µF 25V
C9529	1-125-891-11	CERAMIC CHIP	0.47µF 10% 10V
C9530	1-125-891-11	CERAMIC CHIP	0.47µF 10% 10V
C9531	1-126-964-11	ELECT	10µF 20% 50V
C9532	1-125-891-11	CERAMIC CHIP	0.47µF 10% 10V
C9533	1-125-891-11	CERAMIC CHIP	0.47µF 10% 10V
C9534	1-125-891-11	CERAMIC CHIP	0.47µF 10% 10V
C9535	1-125-891-11	CERAMIC CHIP	0.47µF 10% 10V
C9536	1-126-964-11	ELECT	10µF 20% 50V
C9537	1-125-891-11	CERAMIC CHIP	0.47µF 10% 10V
C9538	1-125-891-11	CERAMIC CHIP	0.47µF 10% 10V
C9539	1-164-156-11	CERAMIC CHIP	0.1µF 25V
C9540	1-107-826-11	CERAMIC CHIP	0.1µF 10% 16V
C9541	1-162-970-11	CERAMIC CHIP	0.01µF 10% 25V
C9542	1-125-837-91	CERAMIC CHIP	1µF 10% 6.3V
C9544	1-107-826-11	CERAMIC CHIP	0.1µF 10% 16V
C9545	1-126-964-11	ELECT	10µF 20% 50V
C9546	1-126-964-11	ELECT	10µF 20% 50V
C9547	1-126-964-11	ELECT	10µF 20% 50V
C9548	1-126-964-11	ELECT	10µF 20% 50V
C9549	1-164-360-11	CERAMIC CHIP	0.1µF 16V
C9550	1-126-964-11	ELECT	10µF 20% 50V
C9551	1-126-964-11	ELECT	10µF 20% 50V
C9552	1-126-964-11	ELECT	10µF 20% 50V
C9553	1-125-891-11	CERAMIC CHIP	0.47µF 10% 10V
C9554	1-125-891-11	CERAMIC CHIP	0.47µF 10% 10V
C9555	1-125-891-11	CERAMIC CHIP	0.47µF 10% 10V
C9556	1-125-891-11	CERAMIC CHIP	0.47µF 10% 10V
C9557	1-107-714-11	ELECT	10µF 20% 50V
C9558	1-107-714-11	ELECT	10µF 20% 50V
C9561	1-126-933-11	ELECT	100µF 20% 16V
C9564	1-107-826-11	CERAMIC CHIP	0.1µF 10% 16V
< CONNECTOR >			
CN9400	1-564-528-11	PLUG, CONNECTOR 13P	
*CN9401	1-793-923-11	CONNECTOR, DIN (PLUG) 64P	
*CN9402	1-564-524-11	PLUG, CONNECTOR 9P	
*CN9404	1-564-519-11	PLUG, CONNECTOR 4P	
*CN9405	1-564-521-11	PLUG, CONNECTOR 6P	
*CN9406	1-564-520-11	PLUG, CONNECTOR 5P	
< DIODE >			
D9400	8-719-081-97	DIODE MMDL914T1	
D9401	8-719-081-97	DIODE MMDL914T1	
D9416	8-719-977-28	DIODE DTZ10B	
D9425	8-719-977-28	DIODE DTZ10B	
D9430	8-719-041-97	DIODE MA113-(TX)	
D9431	8-719-081-97	DIODE MMDL914T1	

REF. NO.	PART NO.	DESCRIPTION	REMARK
D9432	8-719-041-97	DIODE MA113-(TX)	
D9433	8-719-977-28	DIODE DTZ10B	
D9434	8-719-050-37	DIODE M1MA152WA-T1	
D9435	8-719-914-43	DIODE DAN202K	
D9438	8-719-977-28	DIODE DTZ10B	
D9440	8-719-977-28	DIODE DTZ10B	
D9441	8-719-977-28	DIODE DTZ10B	
D9445	8-719-977-28	DIODE DTZ10B	
D9446	8-719-977-28	DIODE DTZ10B	
< FERRITE BEAD >			
FB9400	1-414-228-11	FERRITE	0µH
< FILTER >			
FL9400	1-400-087-21	FILTER, EMI REMOVAL (SMD)	
< IC >			
IC9400	8-752-080-04	IC CXA2069Q	
IC9401	8-752-080-04	IC CXA2069Q	
IC9402	8-752-108-36	IC CXA2171AQ-T6	
IC9403	8-759-278-58	IC NJM4558V-TE2	
IC9404	8-759-548-56	IC M52055FP	
IC9405	8-759-278-58	IC NJM4558V-TE2	
< JACK >			
J9400	1-815-015-11	JACK BLOCK, PIN (HD/DVD IN 6)	
J9401	1-573-967-12	BLOCK, (S) TERMINAL (VIDEO IN 1/3)	
J9402	1-815-015-11	JACK BLOCK, PIN (HD/DVD IN 5)	
J9404	1-764-143-11	JACK (CONTROL S IN)	
J9408	1-793-725-11	JACK BLOCK, PIN 2P (AUDIO OUT (VAR/FIX))	
J9409	1-774-748-11	TERMINAL BLOCK, S (VIDEO IN 4)	
J9410	1-764-143-11	JACK (CONTROL S OUT)	
< COIL >			
L9401	1-469-856-21	INDUCTOR	10µH
L9402	1-469-856-21	INDUCTOR	10µH
L9403	1-412-058-11	INDUCTOR	10µH
L9404	1-469-856-21	INDUCTOR	10µH
< TRANSISTOR >			
Q9400	8-729-026-53	TRANSISTOR 2SA1576A-T106-QR	
Q9401	8-729-026-53	TRANSISTOR 2SA1576A-T106-QR	
Q9402	8-729-026-53	TRANSISTOR 2SA1576A-T106-QR	
Q9403	8-729-026-53	TRANSISTOR 2SA1576A-T106-QR	
Q9404	8-729-905-35	TRANSISTOR 2SC4081-R	
Q9405	8-729-905-35	TRANSISTOR 2SC4081-R	
Q9406	8-729-905-35	TRANSISTOR 2SC4081-R	
Q9407	8-729-905-35	TRANSISTOR 2SC4081-R	
Q9408	8-729-026-53	TRANSISTOR 2SA1576A-T106-QR	
Q9409	8-729-905-35	TRANSISTOR 2SC4081-R	
Q9410	8-729-905-35	TRANSISTOR 2SC4081-R	
Q9411	8-729-026-53	TRANSISTOR 2SA1576A-T106-QR	
Q9412	8-729-026-53	TRANSISTOR 2SA1576A-T106-QR	
Q9413	8-729-026-53	TRANSISTOR 2SA1576A-T106-QR	
Q9414	8-729-026-53	TRANSISTOR 2SA1576A-T106-QR	
Q9415	8-729-026-53	TRANSISTOR 2SA1576A-T106-QR	
Q9416	8-729-907-00	TRANSISTOR DTC114EU	



REF. NO.	PART NO.	DESCRIPTION	REMARK	REF. NO.	PART NO.	DESCRIPTION	REMARK
Q9417	8-729-907-00	TRANSISTOR DTC114EU		R9451	1-216-821-11	METAL CHIP 1K 5%	1/10W
Q9418	8-729-026-53	TRANSISTOR 2SA1576A-T106-QR		R9452	1-216-821-11	METAL CHIP 1K 5%	1/10W
Q9419	8-729-905-35	TRANSISTOR 2SC4081-R		R9453	1-216-809-11	METAL CHIP 100 5%	1/10W
Q9420	8-729-907-00	TRANSISTOR DTC114EU		R9454	1-216-825-11	METAL CHIP 2.2K 5%	1/10W
Q9421	8-729-026-53	TRANSISTOR 2SA1576A-T106-QR		R9455	1-216-809-11	METAL CHIP 100 5%	1/10W
Q9422	8-729-905-35	TRANSISTOR 2SC4081-R		R9456	1-216-825-11	METAL CHIP 2.2K 5%	1/10W
Q9423	8-729-905-35	TRANSISTOR 2SC4081-R		R9457	1-216-809-11	METAL CHIP 100 5%	1/10W
Q9424	8-729-026-53	TRANSISTOR 2SA1576A-T106-QR		R9458	1-216-821-11	METAL CHIP 1K 5%	1/10W
Q9425	8-729-026-53	TRANSISTOR 2SA1576A-T106-QR		R9459	1-216-821-11	METAL CHIP 1K 5%	1/10W
Q9426	8-729-905-35	TRANSISTOR 2SC4081-R		R9462	1-218-676-11	METAL CHIP 220 0.5%	1/10W
Q9427	8-729-905-35	TRANSISTOR 2SC4081-R		R9463	1-218-676-11	METAL CHIP 220 0.5%	1/10W
Q9428	8-729-905-35	TRANSISTOR 2SC4081-R		R9464	1-218-676-11	METAL CHIP 220 0.5%	1/10W
		< RESISTOR >		R9465	1-218-676-11	METAL CHIP 220 0.5%	1/10W
R9400	1-216-295-91	SHORT CHIP 0		R9466	1-218-676-11	METAL CHIP 220 0.5%	1/10W
R9403	1-216-295-91	SHORT CHIP 0		R9467	1-216-849-11	METAL CHIP 220K 5%	1/10W
R9404	1-216-809-11	METAL CHIP 100 5%	1/10W	R9468	1-216-849-11	METAL CHIP 220K 5%	1/10W
R9405	1-216-809-11	METAL CHIP 100 5%	1/10W	R9469	1-218-665-11	METAL CHIP 75 0.5%	1/10W
R9406	1-216-821-11	METAL CHIP 1K 5%	1/10W	R9470	1-218-676-11	METAL CHIP 220 0.5%	1/10W
R9407	1-216-821-11	METAL CHIP 1K 5%	1/10W	R9471	1-216-849-11	METAL CHIP 220K 5%	1/10W
R9408	1-216-805-11	METAL CHIP 47 5%	1/10W	R9472	1-216-849-11	METAL CHIP 220K 5%	1/10W
R9409	1-216-805-11	METAL CHIP 47 5%	1/10W	R9473	1-218-676-11	METAL CHIP 220 0.5%	1/10W
R9410	1-218-692-11	METAL CHIP 1K 0.5%	1/10W	R9474	1-218-676-11	METAL CHIP 220 0.5%	1/10W
R9411	1-218-692-11	METAL CHIP 1K 0.5%	1/10W	R9475	1-218-676-11	METAL CHIP 220 0.5%	1/10W
R9412	1-216-825-11	METAL CHIP 2.2K 5%	1/10W	R9476	1-218-676-11	METAL CHIP 220 0.5%	1/10W
R9413	1-216-825-11	METAL CHIP 2.2K 5%	1/10W	R9477	1-218-676-11	METAL CHIP 220 0.5%	1/10W
R9414	1-218-695-11	METAL CHIP 1.3K 0.5%	1/10W	R9478	1-218-676-11	METAL CHIP 220 0.5%	1/10W
R9415	1-216-821-11	METAL CHIP 1K 5%	1/10W	R9479	1-216-849-11	METAL CHIP 220K 5%	1/10W
R9416	1-218-695-11	METAL CHIP 1.3K 0.5%	1/10W	R9480	1-216-849-11	METAL CHIP 220K 5%	1/10W
R9417	1-216-825-11	METAL CHIP 2.2K 5%	1/10W	R9481	1-218-665-11	METAL CHIP 75 0.5%	1/10W
R9418	1-216-809-11	METAL CHIP 100 5%	1/10W	R9482	1-218-665-11	METAL CHIP 75 0.5%	1/10W
R9419	1-216-821-11	METAL CHIP 1K 5%	1/10W	R9483	1-218-665-11	METAL CHIP 75 0.5%	1/10W
R9420	1-216-825-11	METAL CHIP 2.2K 5%	1/10W	R9484	1-216-849-11	METAL CHIP 220K 5%	1/10W
R9421	1-216-825-11	METAL CHIP 2.2K 5%	1/10W	R9485	1-216-849-11	METAL CHIP 220K 5%	1/10W
R9422	1-216-809-11	METAL CHIP 100 5%	1/10W	R9486	1-218-665-11	METAL CHIP 75 0.5%	1/10W
R9423	1-216-825-11	METAL CHIP 2.2K 5%	1/10W	R9487	1-218-665-11	METAL CHIP 75 0.5%	1/10W
R9424	1-216-809-11	METAL CHIP 100 5%	1/10W	R9488	1-218-665-11	METAL CHIP 75 0.5%	1/10W
R9425	1-216-809-11	METAL CHIP 100 5%	1/10W	R9489	1-218-676-11	METAL CHIP 220 0.5%	1/10W
R9426	1-216-825-11	METAL CHIP 2.2K 5%	1/10W	R9490	1-218-676-11	METAL CHIP 220 0.5%	1/10W
R9427	1-216-809-11	METAL CHIP 100 5%	1/10W	R9491	1-218-676-11	METAL CHIP 220 0.5%	1/10W
R9428	1-216-809-11	METAL CHIP 100 5%	1/10W	R9492	1-218-676-11	METAL CHIP 220 0.5%	1/10W
R9429	1-216-864-11	SHORT CHIP 0		R9493	1-218-676-11	METAL CHIP 220 0.5%	1/10W
R9430	1-216-825-11	METAL CHIP 2.2K 5%	1/10W	R9494	1-218-676-11	METAL CHIP 220 0.5%	1/10W
R9431	1-216-825-11	METAL CHIP 2.2K 5%	1/10W	R9495	1-216-849-11	METAL CHIP 220K 5%	1/10W
R9432	1-216-825-11	METAL CHIP 2.2K 5%	1/10W	R9496	1-216-849-11	METAL CHIP 220K 5%	1/10W
R9433	1-216-809-11	METAL CHIP 100 5%	1/10W	R9497	1-216-838-11	METAL CHIP 27K 5%	1/10W
R9434	1-216-864-11	SHORT CHIP 0		R9498	1-216-864-11	SHORT CHIP 0	
R9435	1-216-809-11	METAL CHIP 100 5%	1/10W	R9499	1-216-864-11	SHORT CHIP 0	
R9436	1-216-821-11	METAL CHIP 1K 5%	1/10W	R9500	1-216-836-11	METAL CHIP 18K 5%	1/10W
R9437	1-216-809-11	METAL CHIP 100 5%	1/10W	R9501	1-216-833-11	METAL CHIP 10K 5%	1/10W
R9438	1-216-821-11	METAL CHIP 1K 5%	1/10W	R9502	1-216-841-11	METAL CHIP 47K 5%	1/10W
R9439	1-216-809-11	METAL CHIP 100 5%	1/10W	R9503	1-216-864-11	SHORT CHIP 0	
R9440	1-216-821-11	METAL CHIP 1K 5%	1/10W	R9504	1-216-837-11	METAL CHIP 22K 5%	1/10W
R9441	1-216-821-11	METAL CHIP 1K 5%	1/10W	R9505	1-216-825-11	METAL CHIP 2.2K 5%	1/10W
R9442	1-216-809-11	METAL CHIP 100 5%	1/10W	R9506	1-216-825-11	METAL CHIP 2.2K 5%	1/10W
R9443	1-216-825-11	METAL CHIP 2.2K 5%	1/10W	R9507	1-216-857-11	METAL CHIP 1M 5%	1/10W
R9444	1-216-809-11	METAL CHIP 100 5%	1/10W	R9508	1-216-827-11	METAL CHIP 3.3K 5%	1/10W
R9445	1-216-825-11	METAL CHIP 2.2K 5%	1/10W	R9509	1-218-867-11	METAL CHIP 6.8K 0.5%	1/10W
R9446	1-216-801-11	METAL CHIP 22 5%	1/10W	R9510	1-216-825-11	METAL CHIP 2.2K 5%	1/10W
R9447	1-216-809-11	METAL CHIP 100 5%	1/10W	R9511	1-216-821-11	METAL CHIP 1K 5%	1/10W
R9448	1-216-801-11	METAL CHIP 22 5%	1/10W	R9512	1-216-825-11	METAL CHIP 2.2K 5%	1/10W
R9449	1-216-825-11	METAL CHIP 2.2K 5%	1/10W	R9513	1-216-837-11	METAL CHIP 22K 5%	1/10W
R9450	1-216-825-11	METAL CHIP 2.2K 5%	1/10W	R9514	1-216-837-11	METAL CHIP 22K 5%	1/10W
				R9515	1-216-809-11	METAL CHIP 100 5%	1/10W



REF. NO.	PART NO.	DESCRIPTION	REMARK	REF. NO.	PART NO.	DESCRIPTION	REMARK
R9516	1-216-809-11	METAL CHIP	100 5%	1/10W	R9579	1-216-864-11	SHORT CHIP 0
R9517	1-216-827-11	METAL CHIP	3.3K 5%	1/10W	R9580	1-216-864-11	SHORT CHIP 0
R9518	1-216-827-11	METAL CHIP	3.3K 5%	1/10W	R9581	1-216-864-11	SHORT CHIP 0
R9519	1-216-809-11	METAL CHIP	100 5%	1/10W	R9582	1-216-864-11	SHORT CHIP 0
R9520	1-216-295-91	SHORT CHIP	0		R9583	1-216-864-11	SHORT CHIP 0
R9521	1-216-809-11	METAL CHIP	100 5%	1/10W	R9584	1-216-864-11	SHORT CHIP 0
R9522	1-216-825-11	METAL CHIP	2.2K 5%	1/10W	R9585	1-216-864-11	SHORT CHIP 0
R9523	1-216-809-11	METAL CHIP	100 5%	1/10W	R9587	1-216-864-11	SHORT CHIP 0
R9524	1-216-825-11	METAL CHIP	2.2K 5%	1/10W	R9588	1-216-864-11	SHORT CHIP 0
R9525	1-216-801-11	METAL CHIP	22 5%	1/10W	R9589	1-216-864-11	SHORT CHIP 0
R9526	1-216-853-11	METAL CHIP	470K 5%	1/10W	R9590	1-216-864-11	SHORT CHIP 0
R9527	1-216-853-11	METAL CHIP	470K 5%	1/10W	R9591	1-216-864-11	SHORT CHIP 0
R9528	1-216-801-11	METAL CHIP	22 5%	1/10W	R9592	1-216-864-11	SHORT CHIP 0
R9529	1-216-821-11	METAL CHIP	1K 5%	1/10W	R9593	1-216-864-11	SHORT CHIP 0
R9530	1-218-685-11	METAL CHIP	510 0.5%	1/10W	R9594	1-216-864-11	SHORT CHIP 0
R9531	1-216-825-11	METAL CHIP	2.2K 5%	1/10W	R9595	1-216-864-11	SHORT CHIP 0
R9532	1-216-825-11	METAL CHIP	2.2K 5%	1/10W	R9596	1-216-864-11	SHORT CHIP 0
R9533	1-218-684-11	METAL CHIP	470 0.5%	1/10W	R9597	1-216-864-11	SHORT CHIP 0
R9534	1-216-821-11	METAL CHIP	1K 5%	1/10W	R9598	1-216-864-11	SHORT CHIP 0
R9535	1-218-685-11	METAL CHIP	510 0.5%	1/10W	R9599	1-216-864-11	SHORT CHIP 0
R9536	1-218-684-11	METAL CHIP	470 0.5%	1/10W	R9600	1-216-809-11	METAL CHIP 100 5%
R9537	1-216-809-11	METAL CHIP	100 5%	1/10W	R9601	1-216-809-11	METAL CHIP 100 5%
R9538	1-218-684-11	METAL CHIP	470 0.5%	1/10W	R9602	1-216-809-11	METAL CHIP 100 5%
R9539	1-216-809-11	METAL CHIP	100 5%	1/10W	R9608	1-216-809-11	METAL CHIP 100 5%
R9540	1-218-684-11	METAL CHIP	470 0.5%	1/10W	R9609	1-216-809-11	METAL CHIP 100 5%
R9541	1-216-809-11	METAL CHIP	100 5%	1/10W	R9610	1-216-809-11	METAL CHIP 100 5%
R9542	1-216-864-11	SHORT CHIP	0		R9611	1-216-801-11	METAL CHIP 22 5%
R9543	1-216-809-11	METAL CHIP	100 5%	1/10W	R9612	1-216-801-11	METAL CHIP 22 5%
R9544	1-216-864-11	SHORT CHIP	0		R9613	1-216-851-11	METAL CHIP 330K 5%
R9545	1-216-825-11	METAL CHIP	2.2K 5%	1/10W	R9616	1-216-809-11	METAL CHIP 100 5%
R9546	1-216-825-11	METAL CHIP	2.2K 5%	1/10W	R9617	1-216-809-11	METAL CHIP 100 5%
R9547	1-216-821-11	METAL CHIP	1K 5%	1/10W	R9618	1-216-809-11	METAL CHIP 100 5%
R9548	1-216-821-11	METAL CHIP	1K 5%	1/10W	R9619	1-218-285-11	METAL CHIP 75 5%
R9549	1-216-833-11	METAL CHIP	10K 5%	1/10W	R9620	1-218-285-11	METAL CHIP 75 5%
R9550	1-218-685-11	METAL CHIP	510 0.5%	1/10W	R9621	1-216-809-11	METAL CHIP 100 5%
R9551	1-218-684-11	METAL CHIP	470 0.5%	1/10W	R9622	1-216-809-11	METAL CHIP 100 5%
R9552	1-216-821-11	METAL CHIP	1K 5%	1/10W	R9623	1-216-809-11	METAL CHIP 100 5%
R9553	1-216-821-11	METAL CHIP	1K 5%	1/10W	R9624	1-218-285-11	METAL CHIP 75 5%
R9554	1-216-821-11	METAL CHIP	1K 5%	1/10W	R9625	1-218-285-11	METAL CHIP 75 5%
R9555	1-218-685-11	METAL CHIP	510 0.5%	1/10W	R9626	1-216-821-11	METAL CHIP 1K 5%
R9556	1-216-833-11	METAL CHIP	10K 5%	1/10W	R9627	1-216-797-11	METAL CHIP 10 5%
R9557	1-216-853-11	METAL CHIP	470K 5%	1/10W	R9629	1-216-295-91	SHORT CHIP 0
R9558	1-216-821-11	METAL CHIP	1K 5%	1/10W	R9630	1-218-716-11	METAL CHIP 10K 0.5%
R9559	1-218-684-11	METAL CHIP	470 0.5%	1/10W	R9631	1-216-833-11	METAL CHIP 10K 5%
R9560	1-216-825-11	METAL CHIP	2.2K 5%	1/10W	R9632	1-216-821-11	METAL CHIP 1K 5%
R9561	1-216-825-11	METAL CHIP	2.2K 5%	1/10W	R9633	1-216-821-11	METAL CHIP 1K 5%
R9562	1-216-853-11	METAL CHIP	470K 5%	1/10W	R9634	1-216-821-11	METAL CHIP 1K 5%
R9563	1-216-864-11	SHORT CHIP	0		R9635	1-216-041-00	RES-CHIP 470 5%
R9564	1-216-864-11	SHORT CHIP	0		R9637	1-218-668-11	METAL CHIP 100 0.5%
R9565	1-216-864-11	SHORT CHIP	0		R9638	1-216-806-11	METAL CHIP 56 5%
R9566	1-216-864-11	SHORT CHIP	0		R9639	1-218-668-11	METAL CHIP 100 0.5%
R9567	1-216-864-11	SHORT CHIP	0		R9640	1-216-053-00	RES-CHIP 1.5K 5%
R9568	1-216-864-11	SHORT CHIP	0		R9641	1-216-806-11	METAL CHIP 56 5%
R9569	1-218-665-11	METAL CHIP	75 0.5%	1/10W	R9642	1-218-668-11	METAL CHIP 100 0.5%
R9570	1-218-665-11	METAL CHIP	75 0.5%	1/10W	R9643	1-216-053-00	RES-CHIP 1.5K 5%
R9571	1-216-809-11	METAL CHIP	100 5%	1/10W	R9644	1-216-806-11	METAL CHIP 56 5%
R9572	1-216-809-11	METAL CHIP	100 5%	1/10W	R9645	1-216-864-11	SHORT CHIP 0
R9573	1-216-809-11	METAL CHIP	100 5%	1/10W	R9649	1-216-864-11	SHORT CHIP 0
R9574	1-216-809-11	METAL CHIP	100 5%	1/10W	R9650	1-218-658-11	METAL CHIP 39 0.5%
R9575	1-216-809-11	METAL CHIP	100 5%	1/10W	R9651	1-218-658-11	METAL CHIP 39 0.5%
R9576	1-216-864-11	SHORT CHIP	0		R9652	1-216-829-11	METAL CHIP 4.7K 5%
R9577	1-216-864-11	SHORT CHIP	0		R9653	1-216-829-11	METAL CHIP 4.7K 5%
R9578	1-216-864-11	SHORT CHIP	0		R9654	1-218-665-11	METAL CHIP 75 0.5%
					R9655	1-218-665-11	METAL CHIP 75 0.5%



REF. NO.	PART NO.	DESCRIPTION	REMARK
R9656	1-218-665-11	METAL CHIP	75 0.5% 1/10W
R9657	1-218-285-11	METAL CHIP	75 5% 1/10W
R9658	1-218-285-11	METAL CHIP	75 5% 1/10W
R9659	1-218-285-11	METAL CHIP	75 5% 1/10W
R9660	1-218-285-11	METAL CHIP	75 5% 1/10W
R9661	1-218-867-11	METAL CHIP	6.8K 0.5% 1/10W
R9662	1-216-827-11	METAL CHIP	3.3K 5% 1/10W
R9663	1-218-271-11	METAL CHIP	2K 5% 1/10W
R9664	1-218-271-11	METAL CHIP	2K 5% 1/10W
R9665	1-216-828-11	METAL CHIP	3.9K 5% 1/10W
R9666	1-216-828-11	METAL CHIP	3.9K 5% 1/10W
R9667	1-216-825-11	METAL CHIP	2.2K 5% 1/10W
R9668	1-218-867-11	METAL CHIP	6.8K 0.5% 1/10W
R9669	1-216-827-11	METAL CHIP	3.3K 5% 1/10W
R9670	1-216-809-11	METAL CHIP	100 5% 1/10W
R9671	1-216-821-11	METAL CHIP	1K 5% 1/10W
R9672	1-216-864-11	SHORT CHIP	0
R9673	1-216-864-11	SHORT CHIP	0
R9674	1-216-864-11	SHORT CHIP	0
R9675	1-216-864-11	SHORT CHIP	0
R9677	1-216-864-11	SHORT CHIP	0
R9678	1-216-864-11	SHORT CHIP	0
R9680	1-216-825-11	METAL CHIP	2.2K 5% 1/10W
R9681	1-218-867-11	METAL CHIP	6.8K 0.5% 1/10W
R9682	1-218-867-11	METAL CHIP	6.8K 0.5% 1/10W
R9683	1-216-825-11	METAL CHIP	2.2K 5% 1/10W
R9684	1-216-825-11	METAL CHIP	2.2K 5% 1/10W
< VARISTOR >			
VD9400	1-803-974-21	VARISTOR, CHIP	(1608)
VD9404	1-803-974-21	VARISTOR, CHIP	(1608)
VD9405	1-803-974-21	VARISTOR, CHIP	(1608)
VD9406	1-803-974-21	VARISTOR, CHIP	(1608)
VD9407	1-803-974-21	VARISTOR, CHIP	(1608)
VD9408	1-803-974-21	VARISTOR, CHIP	(1608)
VD9409	1-803-974-21	VARISTOR, CHIP	(1608)
VD9410	1-803-974-21	VARISTOR, CHIP	(1608)
VD9411	1-803-974-21	VARISTOR, CHIP	(1608)
VD9412	1-803-974-21	VARISTOR, CHIP	(1608)
VD9413	1-803-974-21	VARISTOR, CHIP	(1608)
VD9414	1-803-974-21	VARISTOR, CHIP	(1608)
VD9415	1-803-974-21	VARISTOR, CHIP	(1608)
VD9416	1-803-974-21	VARISTOR, CHIP	(1608)
VD9417	1-803-974-21	VARISTOR, CHIP	(1608)
VD9418	1-803-974-21	VARISTOR, CHIP	(1608)
VD9419	1-803-974-21	VARISTOR, CHIP	(1608)
VD9420	1-803-974-21	VARISTOR, CHIP	(1608)
VD9421	1-803-974-21	VARISTOR, CHIP	(1608)
VD9422	1-803-974-21	VARISTOR, CHIP	(1608)
VD9423	1-803-974-21	VARISTOR, CHIP	(1608)
VD9424	1-803-974-21	VARISTOR, CHIP	(1608)
VD9427	1-803-974-21	VARISTOR, CHIP	(1608)
VD9428	1-803-974-21	VARISTOR, CHIP	(1608)
VD9431	1-803-974-21	VARISTOR, CHIP	(1608)
VD9432	1-803-974-21	VARISTOR, CHIP	(1608)
VD9433	1-803-974-21	VARISTOR, CHIP	(1608)
VD9436	1-803-974-21	VARISTOR, CHIP	(1608)
VD9437	1-803-974-21	VARISTOR, CHIP	(1608)
VD9438	1-803-974-21	VARISTOR, CHIP	(1608)
VD9439	1-803-974-21	VARISTOR, CHIP	(1608)
VD9440	1-803-974-21	VARISTOR, CHIP	(1608)
VD9441	1-803-974-21	VARISTOR, CHIP	(1608)

REF. NO.	PART NO.	DESCRIPTION	REMARK
VD9442	1-803-974-21	VARISTOR, CHIP	(1608)
< VIBRATOR >			
X9400	1-795-214-21	VIBRATOR, CERAMIC	(4MHz)

A-1604-652-A UD BOARD, COMPLETE *****			
< CAPACITOR >			
C7001	1-126-395-11	ELECT CHIP	22µF 20% 16V
C7002	1-162-917-11	CERAMIC CHIP	15pF 5% 50V
C7004	1-162-970-11	CERAMIC CHIP	0.01µF 10% 25V
C7005	1-162-970-11	CERAMIC CHIP	0.01µF 10% 25V
C7006	1-124-779-00	ELECT CHIP	10µF 20% 16V
C7007	1-162-917-11	CERAMIC CHIP	15pF 5% 50V
C7008	1-162-970-11	CERAMIC CHIP	0.01µF 10% 25V
C7010	1-162-970-11	CERAMIC CHIP	0.01µF 10% 25V
C7011	1-162-970-11	CERAMIC CHIP	0.01µF 10% 25V
C7012	1-124-779-00	ELECT CHIP	10µF 20% 16V
C7013	1-162-970-11	CERAMIC CHIP	0.01µF 10% 25V
C7014	1-162-970-11	CERAMIC CHIP	0.01µF 10% 25V
C7015	1-162-970-11	CERAMIC CHIP	0.01µF 10% 25V
C7016	1-162-970-11	CERAMIC CHIP	0.01µF 10% 25V
C7017	1-164-156-11	CERAMIC CHIP	0.1µF 25V
C7018	1-162-923-11	CERAMIC CHIP	47pF 5% 50V
C7019	1-162-923-11	CERAMIC CHIP	47pF 5% 50V
C7020	1-162-923-11	CERAMIC CHIP	47pF 5% 50V
C7021	1-124-779-00	ELECT CHIP	10µF 20% 16V
C7022	1-115-416-11	CERAMIC CHIP	0.001µF 5% 25V
C7023	1-162-927-11	CERAMIC CHIP	100pF 5% 50V
C7024	1-124-779-00	ELECT CHIP	10µF 20% 16V
C7025	1-164-156-11	CERAMIC CHIP	0.1µF 25V
C7026	1-124-779-00	ELECT CHIP	10µF 20% 16V
C7027	1-164-156-11	CERAMIC CHIP	0.1µF 25V
C7028	1-164-156-11	CERAMIC CHIP	0.1µF 25V
C7029	1-164-156-11	CERAMIC CHIP	0.1µF 25V
C7030	1-162-927-11	CERAMIC CHIP	100pF 5% 50V
C7031	1-162-927-11	CERAMIC CHIP	100pF 5% 50V
C7032	1-162-927-11	CERAMIC CHIP	100pF 5% 50V
C7033	1-124-779-00	ELECT CHIP	10µF 20% 16V
C7034	1-164-156-11	CERAMIC CHIP	0.1µF 25V
C7035	1-164-156-11	CERAMIC CHIP	0.1µF 25V
C7036	1-164-156-11	CERAMIC CHIP	0.1µF 25V
C7037	1-164-156-11	CERAMIC CHIP	0.1µF 25V
C7038	1-164-156-11	CERAMIC CHIP	0.1µF 25V
C7039	1-126-395-11	ELECT CHIP	22µF 20% 16V
C7040	1-162-921-11	CERAMIC CHIP	33pF 5% 50V
C7041	1-164-156-11	CERAMIC CHIP	0.1µF 25V
C7042	1-164-156-11	CERAMIC CHIP	0.1µF 25V
C7043	1-164-156-11	CERAMIC CHIP	0.1µF 25V
C7044	1-164-156-11	CERAMIC CHIP	0.1µF 25V
C7045	1-164-156-11	CERAMIC CHIP	0.1µF 25V
C7046	1-164-156-11	CERAMIC CHIP	0.1µF 25V
C7047	1-164-156-11	CERAMIC CHIP	0.1µF 25V
C7048	1-164-156-11	CERAMIC CHIP	0.1µF 25V
C7049	1-164-156-11	CERAMIC CHIP	0.1µF 25V
C7050	1-164-156-11	CERAMIC CHIP	0.1µF 25V
C7051	1-164-156-11	CERAMIC CHIP	0.1µF 25V
C7052	1-164-156-11	CERAMIC CHIP	0.1µF 25V
C7053	1-164-156-11	CERAMIC CHIP	0.1µF 25V



REF. NO.	PART NO.	DESCRIPTION	REMARK
C7056	1-126-395-11	ELECT CHIP 22μF	20% 16V
C7057	1-162-921-11	CERAMIC CHIP 33pF	5% 50V
C7058	1-164-156-11	CERAMIC CHIP 0.1μF	25V
C7059	1-164-156-11	CERAMIC CHIP 0.1μF	25V
C7060	1-164-156-11	CERAMIC CHIP 0.1μF	25V
C7061	1-164-156-11	CERAMIC CHIP 0.1μF	25V
C7062	1-164-156-11	CERAMIC CHIP 0.1μF	25V
C7064	1-126-395-11	ELECT CHIP 22μF	20% 16V
C7065	1-162-970-11	CERAMIC CHIP 0.01μF	10% 25V
C7066	1-162-970-11	CERAMIC CHIP 0.01μF	10% 25V
C7067	1-162-970-11	CERAMIC CHIP 0.01μF	10% 25V
C7068	1-162-970-11	CERAMIC CHIP 0.01μF	10% 25V
C7069	1-162-970-11	CERAMIC CHIP 0.01μF	10% 25V
C7070	1-164-156-11	CERAMIC CHIP 0.1μF	25V
C7071	1-164-156-11	CERAMIC CHIP 0.1μF	25V
C7078	1-164-156-11	CERAMIC CHIP 0.1μF	25V
C7079	1-164-156-11	CERAMIC CHIP 0.1μF	25V
C7080	1-164-156-11	CERAMIC CHIP 0.1μF	25V
< CONNECTOR >			
*CN7001	1-816-228-31	CONNECTOR, DVI (DVI-HDTV IN 7 VIDEO)	
*CN7005	1-564-520-11	PLUG, CONNECTOR 5P	
*CN7006	1-564-524-11	PLUG, CONNECTOR 9P	
*CN7007	1-564-519-11	PLUG, CONNECTOR 4P	
< DIODE >			
D7001	8-719-914-43	DIODE DAN202K	
D7002	8-719-069-55	DIODE UDZSTE-175.6B	
D7003	8-719-069-55	DIODE UDZSTE-175.6B	
D7004	8-719-069-55	DIODE UDZSTE-175.6B	
D7006	8-719-069-55	DIODE UDZSTE-175.6B	
< FERRITE BEAD >			
FB7001	1-414-760-21	FERRITE 0μH	
FB7002	1-414-760-21	FERRITE 0μH	
FB7003	1-414-760-21	FERRITE 0μH	
FB7004	1-414-760-21	FERRITE 0μH	
< FILTER >			
FL7001	1-400-087-21	FILTER, EMI REMOVAL (SMD)	
FL7002	1-234-560-21	FILTER, LOW PASS	
FL7003	1-234-559-21	FILTER, LOW PASS	
FL7004	1-234-559-21	FILTER, LOW PASS	
< IC >			
IC7001	8-759-672-79	IC M24C02-WMN6T(A)	
IC7002	8-749-015-18	IC PQ07VZ012ZP	
IC7003	8-749-015-18	IC PQ07VZ012ZP	
IC7004	6-702-080-01	IC GM7030-H	
IC7005	6-802-346-01	IC ST72631K4M1/NNLTR	
IC7006	8-759-714-06	IC M24C16-WMN6T(A)	
IC7007	6-702-170-01	IC PACDN006S	
IC7008	6-702-170-01	IC PACDN006S	
IC7009	6-702-170-01	IC PACDN006S	
< JACK >			
J7000	1-580-441-51	JACK, PIN 2P (DVI-HDTV IN 7 AUDIO)	
< COIL >			
L7001	1-412-058-11	INDUCTOR 10μH	

REF. NO.	PART NO.	DESCRIPTION	REMARK
L7002	1-412-058-11	INDUCTOR 10μH	
< RESISTOR >			
R7003	1-216-821-11	METAL CHIP 1K	5% 1/10W
R7004	1-218-852-11	METAL CHIP 1.6K	0.5% 1/10W
R7007	1-216-821-11	METAL CHIP 1K	5% 1/10W
R7012	1-216-821-11	METAL CHIP 1K	5% 1/10W
R7013	1-216-821-11	METAL CHIP 1K	5% 1/10W
R7014	1-216-821-11	METAL CHIP 1K	5% 1/10W
R7015	1-216-833-11	METAL CHIP 10K	5% 1/10W
R7016	1-216-833-11	METAL CHIP 10K	5% 1/10W
R7020	1-216-833-11	METAL CHIP 10K	5% 1/10W
R7021	1-216-833-11	METAL CHIP 10K	5% 1/10W
R7023	1-216-833-11	METAL CHIP 10K	5% 1/10W
R7024	1-216-833-11	METAL CHIP 10K	5% 1/10W
R7025	1-216-833-11	METAL CHIP 10K	5% 1/10W
R7026	1-216-833-11	METAL CHIP 10K	5% 1/10W
R7029	1-218-692-11	METAL CHIP 1K	0.5% 1/10W
R7030	1-216-864-11	SHORT CHIP 0	
R7032	1-218-676-11	METAL CHIP 220	0.5% 1/10W
R7034	1-218-676-11	METAL CHIP 220	0.5% 1/10W
R7036	1-218-704-11	METAL CHIP 3.3K	0.5% 1/10W
R7037	1-218-676-11	METAL CHIP 220	0.5% 1/10W
R7040	1-216-833-11	METAL CHIP 10K	5% 1/10W
R7041	1-216-833-11	METAL CHIP 10K	5% 1/10W
R7042	1-164-156-11	CERAMIC CHIP 0.1μF	25V
R7043	1-216-829-11	METAL CHIP 4.7K	5% 1/10W
R7044	1-216-829-11	METAL CHIP 4.7K	5% 1/10W
R7045	1-216-833-11	METAL CHIP 10K	5% 1/10W
R7047	1-216-833-11	METAL CHIP 10K	5% 1/10W
R7050	1-216-864-11	SHORT CHIP 0	
R7051	1-216-864-11	SHORT CHIP 0	
R7053	1-216-833-11	METAL CHIP 10K	5% 1/10W
R7054	1-216-833-11	METAL CHIP 10K	5% 1/10W
R7056	1-216-833-11	METAL CHIP 10K	5% 1/10W
R7057	1-216-864-11	SHORT CHIP 0	
R7058	1-216-833-11	METAL CHIP 10K	5% 1/10W
R7059	1-216-864-11	SHORT CHIP 0	
R7060	1-216-833-11	METAL CHIP 10K	5% 1/10W
R7062	1-216-864-11	SHORT CHIP 0	
R7063	1-216-809-11	METAL CHIP 100	5% 1/10W
R7064	1-216-809-11	METAL CHIP 100	5% 1/10W
R7065	1-216-833-11	METAL CHIP 10K	5% 1/10W
R7066	1-218-694-11	METAL CHIP 1.2K	0.5% 1/10W
R7067	1-216-833-11	METAL CHIP 10K	5% 1/10W
R7068	1-216-801-11	METAL CHIP 22	5% 1/10W
R7069	1-216-801-11	METAL CHIP 22	5% 1/10W
R7071	1-216-803-11	METAL CHIP 33	5% 1/10W
R7072	1-216-803-11	METAL CHIP 33	5% 1/10W
R7075	1-218-676-11	METAL CHIP 220	0.5% 1/10W
R7080	1-218-704-11	METAL CHIP 3.3K	0.5% 1/10W
R7087	1-218-680-11	METAL CHIP 330	0.5% 1/10W
R7096	1-216-833-11	METAL CHIP 10K	5% 1/10W
R7097	1-216-809-11	METAL CHIP 100	5% 1/10W
R7098	1-216-809-11	METAL CHIP 100	5% 1/10W
R7099	1-216-809-11	METAL CHIP 100	5% 1/10W
R7101	1-216-864-11	SHORT CHIP 0	
R7106	1-216-833-11	METAL CHIP 10K	5% 1/10W
R7108	1-216-805-11	METAL CHIP 47	5% 1/10W
R7109	1-216-805-11	METAL CHIP 47	5% 1/10W
R7111	1-216-864-11	SHORT CHIP 0	
R7112	1-216-864-11	SHORT CHIP 0	
R7113	1-216-864-11	SHORT CHIP 0	

Les composants identifiés par une trame et une marque Δ sont critiques pour la sécurité. Ne les remplacer que par une pièce portant le numéro spécifié.

The components identified by shading and mark Δ are critical for safety. Replace only with part number specified.

KF-42WE610/50WE610/60WE610

RM-Y913

RM-Y913

RM-Y913



REF. NO.	PART NO.	DESCRIPTION	REMARK
R7114	1-218-700-11	METAL CHIP	2.2K 0.5% 1/10W
R7115	1-218-700-11	METAL CHIP	2.2K 0.5% 1/10W
R7116	1-218-700-11	METAL CHIP	2.2K 0.5% 1/10W
R7117	1-218-668-11	METAL CHIP	100 0.5% 1/10W
R7119	1-218-668-11	METAL CHIP	100 0.5% 1/10W
R7121	1-216-864-11	SHORT CHIP	0
R7123	1-218-704-11	METAL CHIP	3.3K 0.5% 1/10W
R7124	1-218-680-11	METAL CHIP	330 0.5% 1/10W
R7125	1-218-700-11	METAL CHIP	2.2K 0.5% 1/10W
R7126	1-216-864-11	SHORT CHIP	0

< VIBRATOR >

X7001	1-795-568-21	VIBRATOR, CRYSTAL 14.31818MHz
X7002	1-795-567-21	VIBRATOR, CRYSTAL 12MHz

MISCELLANEOUS

Δ 1-468-798-11	POWER SUPPLY BLOCK
1-500-603-11	CLAMP, FERRITE
* 1-555-110-00	CABLE, P-P
* 1-557-056-31	CABLE, P-P
Δ 1-769-837-11	CORD, POWER(WITH NOISE FILTER)

1-771-787-13	SWITCH, RF ANTENNA
1-787-057-11	D.C. FAN
1-900-277-35	CONNECTOR ASSY 14P LVDS (YEL) C2-DIC
1-900-277-36	CONNECTOR ASSY 14P LVDS (BLK) C2-C1
1-900-277-37	CONNECTOR ASSY 14P LVDS (RED) C2-C1

ACCESSORIES & PACKING MATERIALS

3-704-046-31	BAG,PREVENTION,ELECTRIFICATION
* 4-041-423-01	SHEET, PROTECTION (42WE610)
* 4-042-463-01	SHEET, PROTECTION (50WE610/60WE610)
* 4-049-155-01	BAG, PROTECTION (42WE610)
* 4-095-594-02	INDIVIDUAL CARTON (42WE610)
* 4-095-595-01	TRAY (42WE610)
* 4-095-597-01	CUSHION, UPPER (42WE610)
* 4-095-598-01	CUSHION LOWER (42WE610)
* 4-095-632-02	INDIVIDUAL CARTON (50WE610)
* 4-095-633-01	TRAY (50WE610)
* 4-095-635-01	CUSHION UPPER (50WE610)
* 4-095-636-01	CUSHION LOWER (50WE610)
* 4-095-637-02	INDIVIDUAL CARTON (60WE610)
* 4-095-638-01	TRAY (60WE610)
* 4-098-862-01	BOARD, TOP (50WE610)
* 4-095-640-01	BOARD, TOP (60WE610)
* 4-095-634-01	BOARD, BOTTOM (50WE610)
* 4-095-641-01	CUSHION, UPPER (60WE610)
* 4-095-642-01	CUSHION UPPER (CENTER) (60WE610)
* 4-095-643-01	CUSHION, LOWER (60WE610)
4-097-546-11	MANUAL, INSTRUCTION
4-097-546-21	MANUAL, INSTRUCTION
4-097-546-31	MANUAL, INSTRUCTION
X-4040-886-1	ASSY, CLEANING CLOTH

REF. NO.	PART NO.	DESCRIPTION	REMARK
		REMOTE COMMANDER	*****
1-478-295-11		REMOTE COMMANDER (RM-Y913)	
9-885-042-69		COVER,BATTERY	(FOR REMOTE COMMANDER)

SONY[®]

4-097-546-11 (1)

GRAND WEGA



**LCD Projection TV
HD-Monitor
Operating Instructions**

**KF-42WE610
KF-50WE610
KF-60WE610**

DRC-MFv1
Digital Reality Creation

MEMORY STICK™

WARNING

To prevent fire or shock hazard, do not expose the LCD Projection TV to rain or moisture.

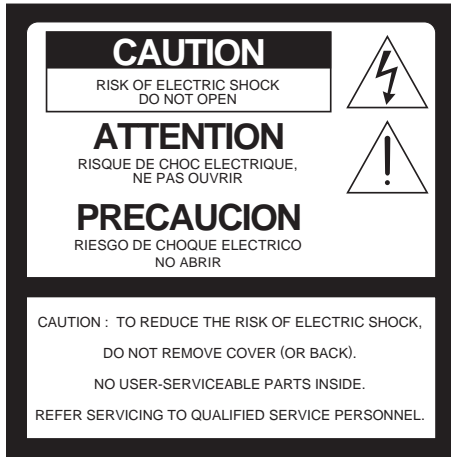

This symbol is intended to alert the user to the presence of uninsulated “dangerous voltage” within the product’s enclosure that may be of sufficient magnitude to constitute a risk of electric shock to persons.



This symbol is intended to alert the user to the presence of important operating and maintenance (servicing) instructions in the literature accompanying the appliance.

CAUTION

To prevent electric shock, do not use this polarized AC plug with an extension cord, receptacle or other outlet unless the blades can be fully inserted to prevent blade exposure.

Note on Caption Vision

This television receiver provides display of television closed captioning in accordance with §15.119 of the FCC rules.

Note to CATV system installer

This reminder is provided to call the CATV system installer’s attention to Article 820-40 of the NEC that provides guidelines for proper grounding and, in particular, specifies that the cable ground shall be connected to the grounding system of the building, as close to the point of cable entry as practical.

Use of this television receiver for other than private viewing of programs broadcast on UHF, VHF, transmitted by cable companies or satellite for the use of the general public may require authorization from the broadcaster/cable company and/or program owner.

NOTIFICATION

This equipment has been tested and found to comply with the limits for a Class B digital device pursuant to Part 15 of the FCC Rules. These limits are designed to provide reasonable protection against harmful interference in a residential installation. This equipment generates, uses, and can radiate radio frequency energy and, if not installed and used in accordance with the instructions, may cause harmful interference with radio communications. However, there is no guarantee that interference will not occur in a particular installation. If this equipment does cause harmful interference to radio or television reception, which can be determined by turning the equipment off and on, the user is encouraged to try to correct the interference by one or more of the following measures:

- Reorient or relocate the receiving antennas.
- Increase the separation between the equipment and receiver.
- Connect the equipment into an outlet on a circuit different from that to which the receiver is connected.
- Consult the dealer or an experienced radio/TV technician for help.

You are cautioned that any changes or modifications not expressly approved in this manual could void your warranty and your authority to operate this equipment.

This document is for the remote control RM-Y913.
MODEL: KF-42WE610, KF-50WE610, KF-60WE610
Please keep this notice with the instruction manual.

Safety

- ❑ Operate the LCD Projection TV only on 120 V AC.
- ❑ The plug is designed, for safety purposes, to fit into the wall outlet only one way. If you are unable to insert the plug fully into the outlet, contact your dealer.
- ❑ If any liquid or solid object should fall inside the cabinet, unplug the LCD Projection TV immediately and have it checked by qualified service personnel before operating it further.
- ❑ If you will not be using the LCD Projection TV for several days, disconnect the power by pulling the plug itself. Never pull on the cord.

For details concerning safety precautions, see “Important Safeguards” on page 4.

Installing

- ❑ To prevent internal heat buildup, do not block the ventilation openings.
- ❑ Do not install the LCD Projection TV in a hot or humid place, or in a place subject to excessive dust or mechanical vibration.
- ❑ Avoid operating the LCD Projection TV at temperature below 41°F (5°C).
- ❑ If the LCD Projection TV is transported directly from a cold to a warm location, or if the room temperature changes suddenly, the picture may be blurred or show poor color. In this case, please wait a few hours to let the moisture evaporate before turning on the LCD Projection TV.
- ❑ To obtain the best picture, do not expose the screen to direct illumination or direct sunlight. It is recommended to use spot lighting directed down from the ceiling or to cover the windows that face the screen with opaque drapery. It is desirable to install the LCD Projection TV in a room where the floor and walls are not of a reflective material.



As an ENERGY STAR® Partner, Sony Corporation has determined that this product meets the ENERGY STAR® guidelines for energy efficiency.

ENERGY STAR® is a U.S. registered mark.

TruSurround, SRS and the (●)® symbol are trademarks of SRS Labs, Inc.

TruSurround technology is incorporated under license from SRS Labs, Inc.

BBE and BBE Symbol are trademarks of BBE Sound, Inc. and are licensed by BBE Sound, Inc. under U.S. Patent No. 4,638,258 and 4,482,866.

ATTENTION

Pour prévenir les chocs électriques, ne pas utiliser cette fiche polarisée avec un prolongateur, une prise de courant ou une autre sortie de courant, sauf si les lames peuvent tre insérées à fond sans en laisser aucune partie à découvert.

Owner's Record

The model and serial numbers are located at the rear of the LCD Projection TV, below the Sony logo, on the sticker, and also on the TV box (white label). Record these numbers in the spaces provided below. Refer to them whenever you call upon your Sony dealer regarding this product.

Model No. _____

Serial No. _____

Important Safety Instruction

- 1) Read these instructions.
- 2) Keep these instructions.
- 3) Heed all warnings.
- 4) Following all instructions.
- 5) Do not use this apparatus near water.
- 6) Clean only with dry cloth.
- 7) Do not block any ventilation openings. Install in accordance with the manufacturer's instructions.
- 8) Do not install near any heat sources such as radiators, heat registers, stoves, or other apparatus (including amplifiers) that produce heat.
- 9) Do not defeat the safety purpose of the polarized or grounding-type plug. A polarized plug has two blades with one wider than the other. A grounding type plug has two blades and a third grounding prong. The wide blade or the third prong are provided for your safety. If the provided plug does not fit into your outlet, consult an electrician for replacement of the obsolete outlet.
- 10) Protect the power cord from being walked on or pinched particularly at plugs, convenience receptacles, and the point where they exit from the apparatus.
- 11) Only use attachments/accessories specified by the manufacturer.
- 12) Use only with the cart stand, tripod, bracket, or table specified by the manufacturer, or sold with the apparatus. When a cart is used, use caution when moving the cart/apparatus combination to avoid injury from tip-over.
- 13) Unplug this apparatus during lightning storms or when unused for long periods of time.
- 14) Refer all servicing to qualified service personnel. Servicing is required when the apparatus has been damaged in any way, such as power-supply cord or plug is damaged, liquid has been spilled or objects have fallen into the apparatus, the apparatus has been exposed to rain or moisture, does not operate normally, or has been dropped.
- 15) Apparatus shall not be exposed to dripping or splashing and no objects filled with liquids, such as vases, shall be placed on the apparatus.

Important Safeguards

For your protection, please read these instructions completely, and keep this manual for future reference.

Carefully observe and comply with all warnings, cautions and instructions placed on the set or described in the operating instructions or service manual.

WARNING

To guard against injury, the following basic safety precautions should be observed in the installation, use and servicing of the set.

Use

Power Sources

This set should be operated only from the type of power source indicated on the serial/model plate. If you are not sure of the type of electrical power supplied to your home, consult your dealer or local power company. For those sets designed to operate from battery power, refer to the operating instructions.



Grounding or Polarization

This set is equipped with a polarized AC power cord plug (a plug having one blade wider than the other), or with a three-wire grounding type plug (a plug having a third pin for grounding). Follow the instructions below:

For the set with a polarized AC power cord plug

This plug will fit into the power outlet only one way. This is a safety feature. If you are unable to insert the plug fully into the outlet, try reversing the plug. If the plug still fails to fit, contact your electrician to have a suitable outlet installed. Do not defeat the safety purpose of the polarized plug by forcing it in.

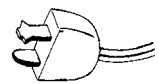

Alternate Warning for the set with a three-wire grounding type AC plug

This plug will only fit into a grounding-type power outlet. This is a safety feature. If you are unable to insert the plug into the outlet, contact your electrician to have a suitable outlet installed. Do not defeat the safety purpose of the grounding plug.

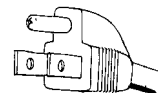

Overloading

Do not overload wall outlets, extension cords or convenience receptacles beyond their capacity, since this can result in fire or electric shock.

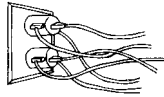

Always turn the set off when it is not being used. When the set is left unattended and unused for long periods of time, unplug it from the wall outlet as a precaution against the possibility of an internal malfunction that could create a fire hazard.



If a snapping or popping sound from a TV set is continuous or frequent while the TV is operating, unplug the TV and consult your dealer or service technician. It is normal for some TV sets to make occasional snapping or popping sounds, particularly when being turned on or off.

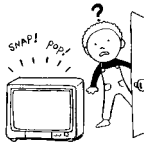

Object and Liquid Entry

Never push objects of any kind into the set through the cabinet slots as they may touch dangerous voltage points or short out parts that could result in a fire or electric shock. Never spill liquid of any kind on the set.



Attachments

Do not use attachments not recommended by the manufacturer, as they may cause hazards.

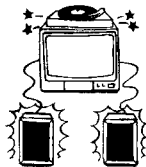

Cleaning

Clean the cabinet of the LCD Projection TV with a dry soft cloth. To remove dust from the screen, wipe it gently with a soft cloth. Stubborn stains may be removed with a cloth slightly dampened with solution of mild soap and warm water. Never use strong solvents such as thinner or benzine for cleaning.



If the picture becomes dark after using the LCD Projection TV for a long period of time, it may be necessary to clean the inside of the LCD Projection TV. Consult qualified service personnel.

On contamination on the screen surface

The screen surface has a special coating to reduce a picture displayed by reflecting. If you clean the screen surface in the wrong way, the screen may be damaged. To clean the screen, do as follows:

- ❑ Clean the screen with a soft cloth, such as the supplied cleaning cloth or a glass cleaning cloth.
- ❑ To remove hard contamination, use the supplied cleaning cloth or a glass cleaning cloth moistened with a solution of mild detergent and water.
- ❑ Do not use any type of abrasive pad, alkaline cleaner, acid cleaner, scouring powder, chemical cloth, or solvent such as alcohol, benzene or thinner, as these may scratch the screen's coating.

Installation

Water and Moisture

Do not use power-line operated sets near water — for example, near a bathtub, washbowl, kitchen sink, or laundry tub, in a wet basement, or near a swimming pool, etc.



Accessories

Do not place the set on an unstable cart, stand, table or shelf. The set may fall, causing serious injury to a child or an adult and serious damage to the set. Use only a cart or stand recommended by the manufacturer for the specific model of LCD Projection TV. An appliance and cart combination should be moved with care. Quick stops, excessive force, and uneven surfaces may cause the appliance and cart combination to overturn.



Ventilation

The slots and openings in the cabinet and in the back or bottom are provided for necessary ventilation. To ensure reliable operation of the set, and to protect it from overheating, these slots and openings must never be blocked or covered.

- ❑ Never cover the slots and openings with a cloth or other materials.



- ❑ Never block the slots and openings by placing the set on a bed, sofa, rug or other similar surface.



- ❑ Never place the set in a confined space, such as a bookcase or built-in cabinet, unless proper ventilation is provided.



- ❑ Do not place the set near or over a radiator or heat register, or where it is exposed to direct sunlight.



Power-Cord Protection

Do not allow anything to rest on or roll over the power cord, and do not place the set where the power cord is subject to wear or abuse.



Antennas

Outdoor Antenna Grounding

If an outdoor antenna is installed, follow the precautions below. An outdoor antenna system should not be located in the vicinity of overhead power lines or other electric light or power circuits, or where it can come in contact with such power lines or circuits.

WHEN INSTALLING AN OUTDOOR ANTENNA SYSTEM, EXTREME CARE SHOULD BE TAKEN TO KEEP FROM CONTACTING SUCH POWER LINES OR CIRCUITS AS CONTACT WITH THEM IS ALMOST INVARIABLY FATAL.

Be sure the antenna system is grounded so as to provide some protection against voltage surges and built-up static charges.

Section 810 of the National Electrical Code (NEC) in USA and Section 54 of the Canadian Electrical Code in Canada provides information with respect to proper grounding of the mast and supporting structure, grounding of the lead-in wire to an antenna discharge unit, size of grounding conductors, location of antenna discharge unit, connection to grounding electrodes, and requirements for the grounding electrode.

Antenna Grounding According to the NEC

Refer to section 54-300 of Canadian Electrical Code for Antenna Grounding.

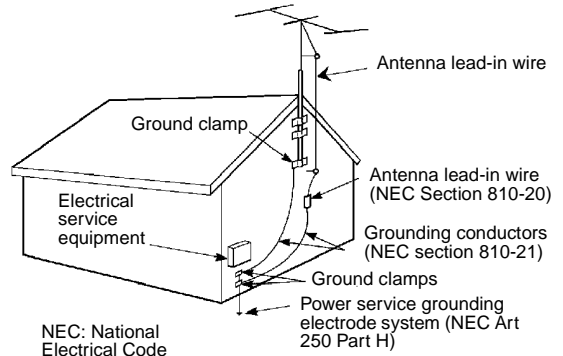





Lightning

For added protection for this television receiver during a lightning storm, or when it is left unattended and unused for long periods of time, unplug it from the wall outlet and disconnect the antenna. This will prevent damage to the receiver due to lightning and power-line surges.

Service

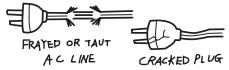
Damage Requiring Service

Unplug the set from the wall outlet and refer servicing to qualified service personnel under the following conditions:

- ❑ When the power cord or plug is damaged or frayed. 
- ❑ If liquid has been spilled into the set. 
- ❑ If the set has been exposed to rain or water.
- ❑ If the set has been subject to excessive shock by being dropped, or the cabinet has been damaged. 
- ❑ If the set does not operate normally when following the operating instructions. Adjust only those controls that are specified in the operating instructions. Improper adjustment of other controls may result in damage and will often require extensive work by a qualified technician to restore the set to normal operation. 
- ❑ When the set exhibits a distinct change in performance, it indicates a need for service. 

Servicing

Do not attempt to service the set by yourself since opening the cabinet may expose you to dangerous voltage or other hazards. Refer all servicing to qualified service personnel.



Replacement Parts

When replacement parts are required, be sure the service technician certifies in writing that he has used replacement parts specified by the manufacturer that have the same characteristics as the original parts.

Unauthorized substitutions may result in fire, electric shock or other hazards.

Safety Check

Upon completion of any service or repairs to the set, ask the service technician to perform routine safety checks (as specified by the manufacturer) to determine that the set is in safe operating condition, and to so certify. When the set reaches the end of its useful life, improper disposal could result in a picture tube implosion. Ask a qualified service technician to dispose of the set.



For Safety

Be careful when moving the LCD Projection TV

When you place the LCD Projection TV in position, be careful not to drop it on your foot or fingers.

Watch your footing while installing the LCD Projection TV.

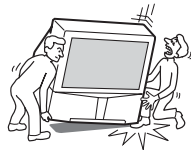

Carry the LCD Projection TV in the specified manner

If you carry the LCD Projection TV in a manner other than the specified manner and without the specified number of persons, it may drop and a serious injury may be caused. Be sure to follow the instructions mentioned below.



- ❑ Carry the LCD Projection TV with the specified number of persons (see page 18).
- ❑ Do not carry the LCD Projection TV holding the speaker grill.
- ❑ Hold the LCD Projection TV tightly when carrying it.

About the LCD Projection TV

Although the LCD projection TV is made with high-precision technology, black dots may appear or bright points of light (red, blue, or green) may appear constantly on the LCD screen. This is a structural property of the LCD panel and is not a malfunction.

Installation

- ❑ If direct sunlight or other strong illumination shines on the screen, part of the screen appears white due to reflections from behind the screen. This is a structural property of the LCD Projection TV. Do not expose the screen to direct illumination or direct sunlight.
- ❑ The picture quality may be affected by your viewing position. If you view the TV close to you, you may suffer from eye fatigue. For the best picture quality, install your LCD projection TV according to the operating instructions. Sit at least 1.8m (approx. 5.9ft.) for KF-42WE610, 2.0m (approx. 6.6ft.) for KF-50WE610 or 2.2m (approx. 7.2ft.) for KF-60WE610 away from your LCD projection TV, and within 60° of the vertical viewing area, and 130° of the horizontal viewing area.
- ❑ When installing your LCD Projection TV against a wall, keep it at least 10 cm (4 inches) from the wall.
- ❑ Avoid installing the LCD projection TV close to high temperature sources such as a heater.

Projection lamp

- ❑ Your LCD projection TV uses a projection lamp as its light source. When the projection lamp wears out after using the LCD projection TV for a long period of time, the screen image becomes dark, or no image will appear on the display. If the lamp replacement indicator of the front panel blinks in red, replace the lamp with a new one (not supplied). In some cases, the lamp bursts inside the lamp unit noisily, but the lamp unit is securely designed so that the pieces of broken glass remain inside the lamp unit. (See "Replacing the Lamp" on page 13.)

Cooling fan

- ❑ This LCD projection TV uses a cooling fan to prevent the internal temperature from heating up. You might hear the noise from the cooling fan, depending on the place you install the LCD projection TV.

Carrying

- ❑ When carrying the LCD projection TV, disconnect the connections.

Remote control detection

- ❑ The remote control detection is at the upper right side. For remote control operations, point it to that position.

Contents

Introducing the Sony LCD Projection TV

Presenting the Sony LCD Projection TV	9
Using This Manual.....	10
Enjoying Your LCD Projection TV	11
Replacing the Lamp	13

Installing and Connecting the LCD Projection TV

Contents	17
Inserting Batteries into the Remote Control	17
Carrying Your LCD Projection TV	18
To Prevent the LCD Projection TV from Falling Down	19
When Installing Your LCD Projection TV Against a Wall	19
Recommended Viewing Area	20
LCD Projection TV Connectors	21
Connector Types	24
Basic Connections (Connecting Cable TV or Antenna).....	25
Connecting a VCR and Cable	29
Connecting a VCR and Cable Box	30
Connecting Two VCRs for Tape Editing	32
Connecting a Satellite Receiver.....	33
Connecting a Satellite Receiver with a VCR.....	34
Connecting an Audio Receiver.....	36
Connecting a DVD Player with Component Video Connectors	37
Connecting a DVD Player with A/V Connectors ..	38
Connecting a Digital TV Receiver with component connectors	39
Connecting a Digital TV Receiver with DVI-HDTV connector.....	40
Connecting a Camcorder	41
Using the CONTROL S Feature.....	42
Setting Up the LCD projection TV Automatically	43

Using the Features

Using the Remote Control	44
Watching the TV.....	46
Watching Digital TV	48
Using Favorite Channels.....	49
Using Twin View™.....	50
Using the Freeze Function.....	53
Using Wide Screen Mode	54

Using the Memory Stick Viewer

About Memory Stick	55
Inserting and Removing a Memory Stick.....	57
Displaying the Memory Stick Home (Memory Stick Index).....	58
Using the Memory Stick Home	60
Viewing Still Images	62
Playing Movies	63
Memory Stick Home Menu Options.....	65

Using the Menus

Overview.....	68
Using the Video Menu.....	69
Using the Audio Menu.....	72
Using the Screen Menu.....	74
Using the Channel Menu	76
Using the Parent Menu	78
Using the Setup Menu	82

Other Information

Programming the Remote Control.....	86
Operating Other Components with Your LCD Projection TV Remote Control.....	88
Notes on Using Memory Stick, Memory Stick PRO Media	90
Notes on Using Memory Stick Duo.....	91
Contacting Sony.....	92
Troubleshooting.....	92
Flashing Indicators on the Front of the Monitor....	98
Specifications.....	99

Introducing the Sony LCD Projection TV

Presenting the Sony LCD Projection TV

Thank you for purchasing the Sony LCD Projection TV.
This manual is for models KF-42WE610, KF-50WE610 and KF-60WE610.

Features

Some of the features that you will enjoy with your new LCD projection TV include:

- ❑ **HD-Monitor:** Enables to display the 1080i, 720p, 480p and 480i digital TV format signals.
By using the HD/DVD IN jacks, you can connect a DTV (digital television) receiver to view DTV programs.
- ❑ **DRC™ (Digital Reality Creation) Multifunction V1:** Unlike conventional line doublers, the DRC feature converts frames reproduced every 1/60th of a second in real time, minimizing the blur or ghost of the motion images (for 480i signals only).
- ❑ **CineMotion™:** Using the reverse 3-2 pull down technology, the CineMotion feature allows you to obtain a smooth picture movement when playing back movies or other video sources on film.
- ❑ **Twin View™:** Using Multi-Image Driver (MID-X), Twin View allows you to watch two programs side by side with the ability to zoom in on one picture and listen to the program in the selected window. You can watch pictures from two different sources (1080i, 720p, 480p or 480i) simultaneously.
- ❑ **Memory Stick® Picture Viewer:** Allows you to view on your LCD Projection TV screen digital images that are stored on Memory Stick media.
- ❑ **Parental Control:** V-Chip technology allows parents to block unsuitable programming for younger viewers.
- ❑ **Digital Visual Interface (DVI-HDTV):** Can accommodate a copy-protected digital connection (HDCP*) to other devices (such as digital set-top boxes) that have compatible interfaces. The DVI-HDTV input terminal is compliant with the EIA-861 standard and is not intended for use with personal computers.

* High-bandwidth Digital Content Protection

(Continued)

- ❑ **Component Video Inputs:** Offers the best video quality for DVD (480p, 480i) and Digital Set-top box (1080i, 720p, 480p, 480i) connections.
- ❑ **S-VIDEO Inputs:** Provides a high-quality image for connected equipment.
- ❑ **Favorite Channel Preview:** Preview up to six-teen favorite channels without leaving the current channel.
- ❑ **Wide Screen Mode:** Allows you to watch 4:3 normal broadcasts in wide screen mode (16:9 aspect ratio).
- ❑ **Auto Wide:** Allows you to select the wide screen mode automatically.

Using This Manual

We recommend that you carefully review the contents of the following three sections in the order shown to ensure that you fully understand the operation of your new LCD projection TV.

- 1 **Installing and Connecting the LCD Projection TV**
This section guides you through your initial setup. It shows you how to install your LCD projection TV, to connect your new components and to connect the antenna and cable.
- 2 **Using the Features**
This section shows you how to begin using your new LCD projection TV. It also shows you how to use your remote control functions.
- 3 **Using the menus**
This section teaches you how to access on-screen menus and adjust your LCD projection TV settings.

Instructions in this manual are written for the remote control. Similar controls are also found on the LCD projection TV console.

Enjoying Your LCD Projection TV

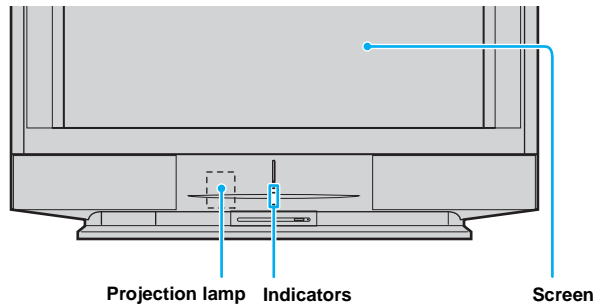

Indicators

The indicators show the current status of your LCD projection TV. If the LAMP indicator flashes, see “Flashing Indicators on the Front of the Monitor” on page 98.

Screen

To minimize screen reflection, its surface has a special coating. Read the instructions “Use of the Cleaning Cloth” on page 12 carefully before cleaning.

Inappropriate cleaning methods could damage the finishing.

Projection lamp

Your LCD projection TV uses a projection lamp as its light source. Note the following:

- ❑ After turning on your LCD projection TV, it may take a while before the picture appears (1 minute or less).
 - ❑ When the projection lamp wears out, the screen image becomes dark. Replace the lamp with a new Sony XL-2100U replacement lamp (not supplied).
- 🔧 Be sure to attach the lamp cover securely; otherwise, your LCD projection TV will not turn on. For details on lamp replacement, see “Replacing the Lamp” on page 13.
 - 🔧 The light emitted from the lamp is quite bright when your LCD projection TV is in use. To avoid eye discomfort or injury, do not look into the housing when the power is on.

Notes on the LCD Projection TV

To enjoy clear pictures

- ❑ Be sure not to allow sunlight or light from a lamp to shine directly onto the screen.
- ❑ The screen surface is easily scratched. Do not rub, touch, or tap it with a sharp or abrasive object (see “Use of the Cleaning Cloth” below).

On moisture condensation

- ❑ If your LCD projection TV is transported directly from a cold to a warm location, is placed in a humid room, or if the room temperature changes suddenly, the picture may be blurred or show poor color. This is because moisture has condensed on the lenses inside. If this happens, leave the power on and let the moisture evaporate before using your LCD projection TV.

When the LCD projection TV will not be used for a long period of time

- ❑ Turn off the main power on the front of your LCD projection TV before going to sleep or going out. Disconnect the AC plug if idle for more than 7 days.

When turning off the power

- ❑ Be sure to turn off the power switch on the main unit or on the remote control. After turning off the power, the fan will continue to blow for about two minutes. Be sure to wait for several minutes after turning the power off when unplugging from the outlet or switching the breaker off.

When carrying the LCD projection TV

- ❑ Disconnect the connections.

Use of the Cleaning Cloth

To remove dust from the front of the screen, wipe with the supplied Cleaning Cloth.

- 🧽 Do not use any type of abrasive pad, alkaline cleaner, scouring powder, window cleaners or solvent such as alcohol or benzene. Otherwise, this type of contact may result in a damaged screen.
- 🧽 To clean the screen, please use the supplied Cleaning Cloth lightly moistened with water diluted mild detergent solution. Do not apply heavy press when cleaning.
- 🧽 The supplied Cleaning Cloth is washable with warm water and a mild detergent solution, and can be used repeatedly.

Replacing the Lamp

The projection lamp has a limited life which illuminates the picture.

If the screen becomes dark, the color looks unusual, or the LAMP indicator on the front of the LCD projection TV flashes, it is time to replace the lamp with a new one (not supplied).

 **WARNING**

Electric appliances can cause fire or high temperature, resulting in injury or death. Be sure to follow the instructions below.

- ❑ Use a Sony XL-2100U replacement lamp (not supplied) for replacement. Failure to do so may damage the LCD projection TV.
- ❑ Do not remove the lamp for any purpose other than replacement. Failure to do so may cause fire or a skin burn.
- ❑ Before replacing the lamp, turn the power off on the main unit, then several minutes later, unplug the power cord. (The cooling fan will continue to blow for about two minutes after turning the power off.)
- ❑ Before replacing the lamp, let it cool down completely, as the surface of the lamp remains extremely hot for at least 30 minutes after the power has been turned off.
- ❑ Do not leave the removed lamp near flammable materials or within the reach of children.
- ❑ Do not pour water onto the removed lamp, or put any object inside the lamp. Doing so may cause the lamp to burst.
- ❑ Do not put flammable materials and metal objects inside the lamp receptacle of the LCD projection TV after removing the lamp. Doing so may cause fire or electrical shock. Also, be sure not to touch the receptacle, because it may cause a skin burn.
- ❑ Mount the new lamp securely, otherwise the screen may become dark, or it may cause a fire.
- ❑ Do not touch the glass with your fingers on the new lamp.

The Used Lamp

The used lamp contains Mercury, Dispose According to Local, State or Federal Laws.

-  Do not touch the front glass of a new lamp or the glass of the lamp receptacle. This may reduce picture quality or lamp life.

(Continued)

- 1 Turn off the power switch on the LCD projection TV and after several minutes, unplug the power cord.
(The cooling fan will continue to blow for about two minutes after turning the power off.)

 Do not touch the front glass of a new lamp or the glass of the lamp receptacle. This may reduce picture quality or lamp life.

- 2 Unplug the power cord after turning off the main power. Wait at least 30 minutes to allow the lamp to cool down before replacing it. Take the new lamp out of the box.
- 3 Loosen the screws on the rear side panel.

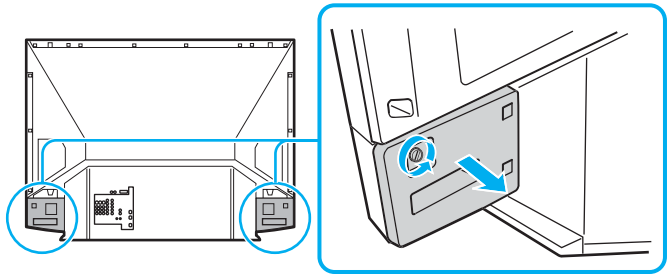

- 4 Remove the front panel.

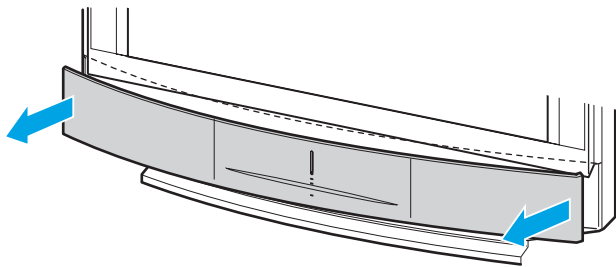

- 5 Loosen the screw with a coin or similar object to remove the lamp cover.

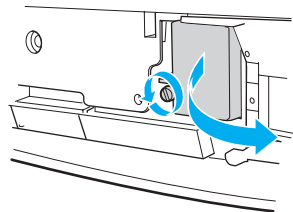

- 6 Loosen the two screws that secure the lamp, then pull out the lamp. The lamp is very hot immediately after use. Never touch the front glass of the lamp or the surrounding parts.

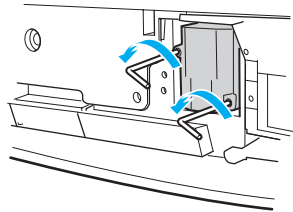

Loosen the two screws with the hex key supplied with the lamp.

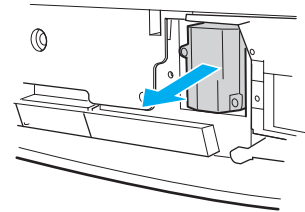

Hold the handle and pull straight out.

After it has cooled, place the removed lamp into the empty box of the replacement lamp. Never put the removed lamp into a plastic bag.

- 7 Mount the new lamp. Be sure to attach the new lamp securely.

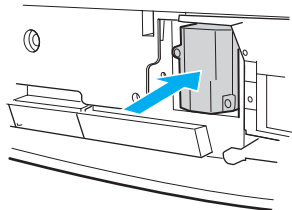

Mount the new lamp securely into the lamp receptacle.

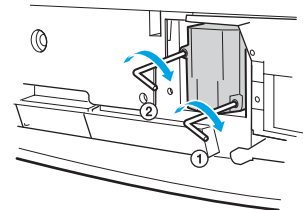

Tighten the two screws securely in the order of ① to ②, as shown in the illustration using the supplied hex key.

- 8 Mount the lamp cover and tighten the screw. Make sure that the lamp cover is mounted securely, otherwise the power will not turn on.

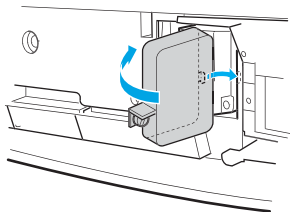

Match the projection of the right side of the lamp cover with the hole of the unit, and replace the lamp cover as it was.

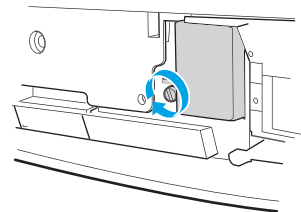

(Continued)

✎ If the lamp cover is not mounted securely, the self-diagnostic function works and the POWER/STANDBY indicator flashes for three times (See page 98).

9 Mount the front panel.

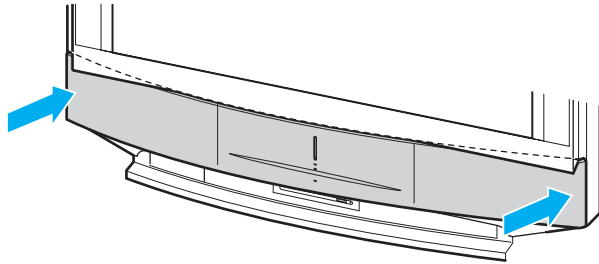

10 Mount the rear side panel and tighten the screws.

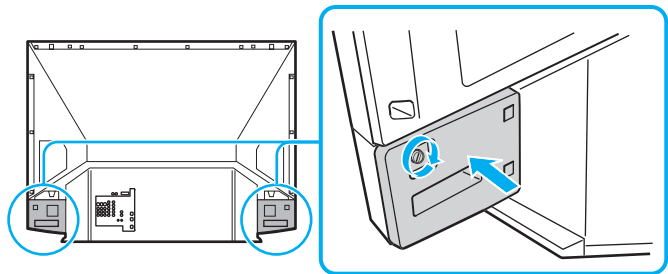

✎ Consult your Sony dealer for a Sony XL-2100U replacement lamp.
✎ Take great care when replacing the lamp or plugging in/unplugging the connecting cords. If you handle them roughly, the LCD projection TV may fall or be moved, and the TV stand or floor surfaces may be scratched.

Installing and Connecting the LCD Projection TV

Contents

The box contains your new LCD projection TV, a remote control and two AA batteries. No peripheral cables are included. If you intend to add additional equipment to your LCD projection TV, please check the hookup instructions for your desired setup before you begin. You may need to purchase cables and/or splitters to complete the hookup properly.

Inserting Batteries into the Remote Control

Insert two size AA batteries (supplied) by matching the + and – on the batteries to the diagram inside the battery compartment.

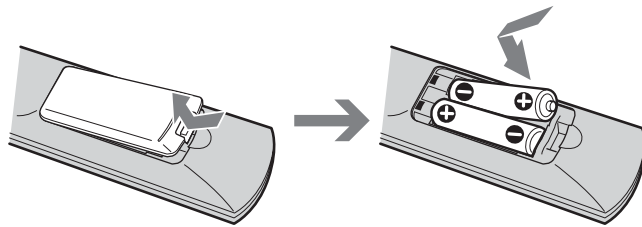

- ✎ Remove the batteries to avoid damage from possible battery leakage whenever you anticipate that the remote control will not be used for an extended period.
- ✎ Handle the remote control with care. Avoid dropping it, getting it wet, or placing it in direct sunlight, near a heater, or where the humidity is high.
- ✎ Your remote control can be programmed to operate most video equipment. (See “Programming the Remote Control” on page 86.)

Carrying Your LCD Projection TV

Carrying the LCD projection TV requires at least two people. Do not grasp the pedestal or the front panel of the LCD projection TV, otherwise these parts might break off.

When moving the LCD projection TV, support the hole on the lower portion with one hand while grasping the top part with the other hand, as shown in the illustration below.

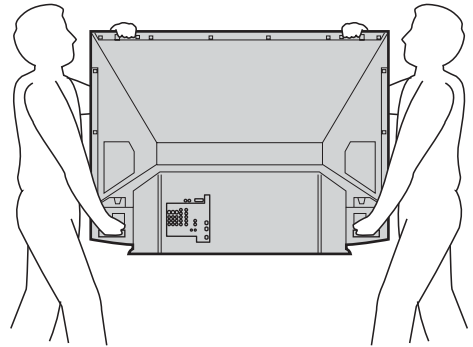

To Prevent the LCD Projection TV from Falling Down

Pay special attention to children around the LCD projection TV. If children should climb onto or push the LCD projection TV or its stand, it may fall down.

As a protective measure, secure the LCD projection TV as follows.

Using the LCD projection TV stand with support belts

- You can also use the LCD projection TV stand SU-GW1 (for KF-50/60WE610, not supplied), SU-GW2 (for KF-42WE610, not supplied) with support belts.

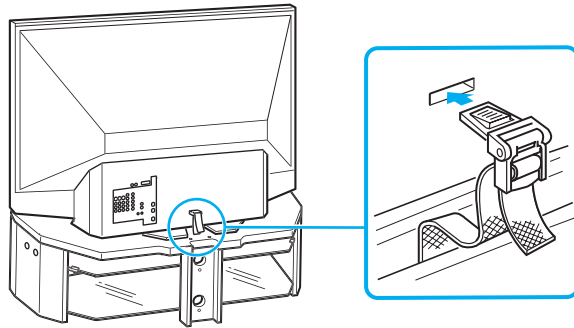

When Installing Your LCD Projection TV Against a Wall

Keep your LCD projection TV at least 10 cm (4 inches) from the wall.

Recommended Viewing Area

The picture quality may be affected by your viewing position.

For the best picture quality, install your LCD projection TV within the areas shown below.

Sit at least 1.8 m (approx. 5.9 ft) for KF-42WE610, 2.0 m (approx. 6.6 ft.) for KF-50WE610 or 2.2 m (approx. 7.2 ft.) away from your LCD projection TV, and within 60° of the vertical viewing area, and 130° of the horizontal viewing area.

Horizontal Viewing Area

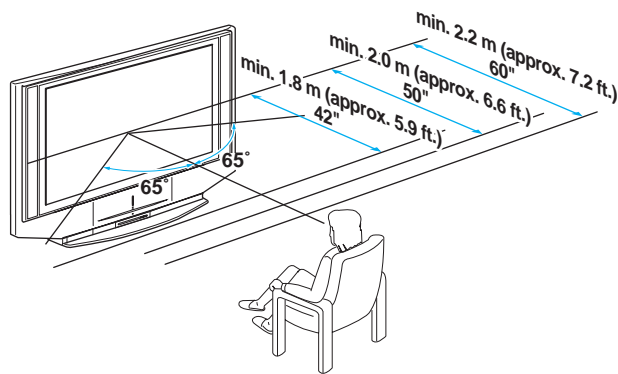

Vertical Viewing Area

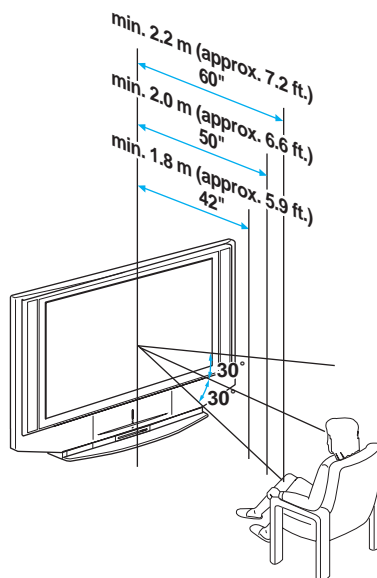

LCD Projection TV Connectors

LCD Projection TV Front and Rear Side Connectors

How to open the front panel

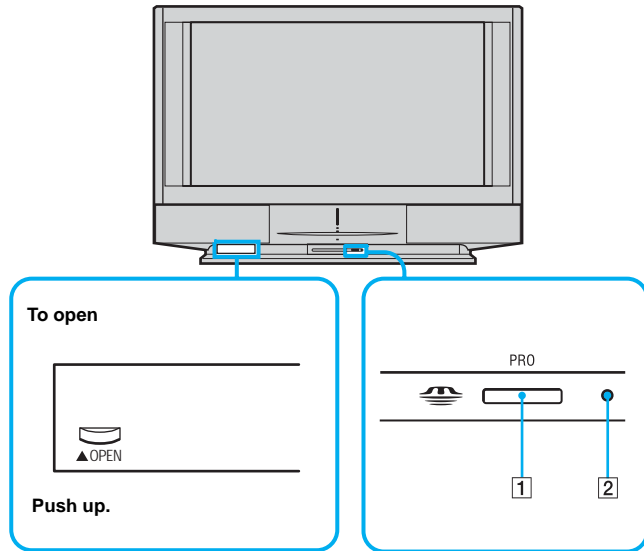

<i>Item</i>	<i>Description</i>
1 MEMORY STICK	Memory Stick insertion slot. For details, see “Inserting and Removing a Memory Stick” on page 57.
2 MEMORY STICK ACCESS LED	When lit, indicates that the Memory Stick is being read. (Do not remove the Memory Stick when the indicator is lit.)

(Continued)

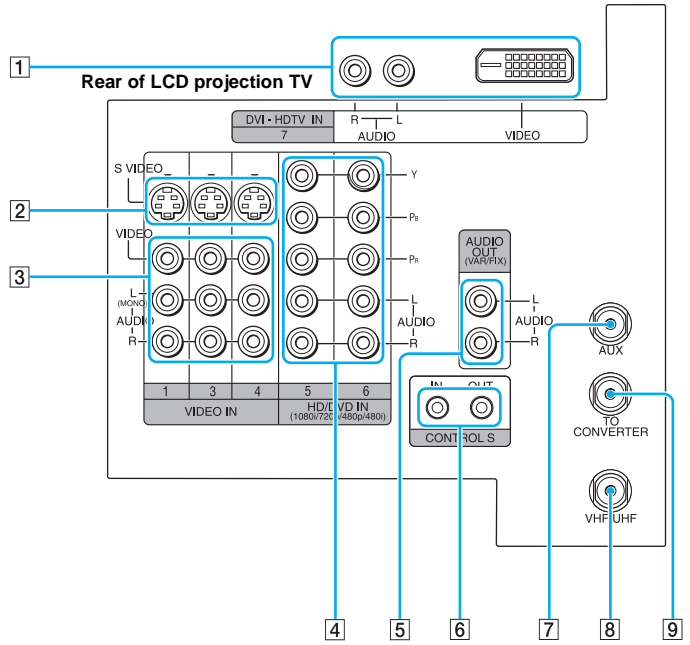

Front left side of LCD projection TV

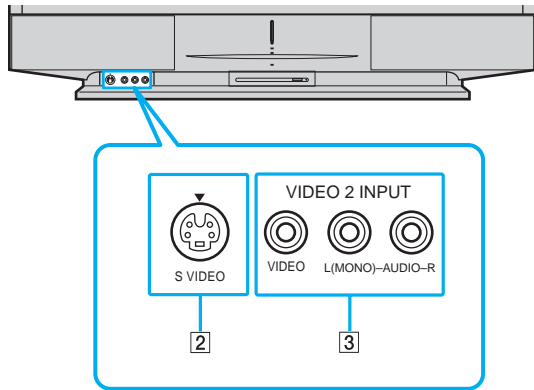

Connection	Description
1 DVI-HDTV VIDEO AUDIO R/L (VIDEO 7 IN)	Can accommodate a copy-protected digital connection (HDCP [*]) to other devices (such as digital set-top boxes) that have compatible interfaces. The DVI-HDTV input terminal is compliant with the EIA-861 standard and is not intended for use with personal computers. See the instruction manual that came with your equipment for details about connecting and using it with the LCD projection TV.
2 S VIDEO (Rear and front)	Connects to the S VIDEO OUT jack of your VCR or other S VIDEO-equipped video component. Provides better picture quality than the VHF/UHF jacks or the Video IN jack.
3 VIDEO/ (L/R) AUDIO (Rear and front)	Connects to the audio and video OUT jacks on your VCR or other video component. A fourth video input (VIDEO 2) is located on the side panel of the LCD projection TV.
4 HD/DVD IN (1080i, 720p, 480p, 480i)	Connects to your DVD player's or Digital Set-top box's component video (Y, Pb, Pr) and audio (L/R) jacks.
5 AUDIO OUT (VAR/FIX) L (MONO)/R	Connects to the left and right audio inputs of your audio or video component.
6 CONTROL S IN/OUT	To control other Sony equipment with the LCD projection TV's remote control, connect the CONTROL S IN jack of the equipment to the CONTROL S OUT jack on the LCD projection TV with the CONTROL S cable. To control the LCD projection TV with a remote control for another Sony product, connect the CONTROL S OUT jack of the equipment to the CONTROL S IN jack on the LCD projection TV with the CONTROL S cable.
7 AUX	Allows you to view local and cable channels if your cable provider does not feature local channels. You can switch between local and cable channels easily by pressing ANT on the remote control. Devices connected to the AUX input cannot be viewed in Twin View.
8 VHF/UHF (Primary RF input)	Connects to your VHF/UHF antenna or cable.
9 TO CONVERTER	This is a VHF/UHF OUT jack that lets you set up your LCD projection TV to switch between scrambled channels (through a cable box) and normal cable channels (CATV). Use this jack instead of a splitter to get better picture quality when switching between scrambled and unscrambled cable channels.

* High-bandwidth Digital Content Protection

Connector Types

You may find it necessary to use some of the following connector types during set up.

Coaxial cable

Standard TV cable and antenna cable

Plug Type



Screw-on Type



S Video cable

High quality video cable for enhanced picture quality



Audio/Video cable



Video - Yellow

Audio (Left) - White

Audio (Right) - Red

Some DVD Players are equipped with the following three video connectors:

Y - Green

P_B (C_B, C_b or B-Y) - Blue

P_R (C_R, C_r or R-Y) - Red

CONTROL S cable

CONTROL S connections are exclusive to Sony products and allow greater control of all Sony equipment.



Basic Connections (Connecting Cable TV or Antenna)

Connecting Directly to Cable or an Antenna

The connection you choose depends on the cable found in your home. Newer homes are equipped with standard coaxial cable (see **A**); older homes probably have 300-ohm twin lead cable (see **B**); other homes may contain both (see **C**).

A VHF Only or VHF/UHF or Cable



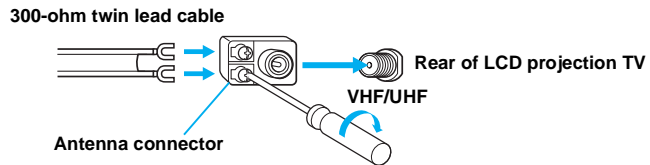

B VHF Only or UHF Only or VHF/UHF

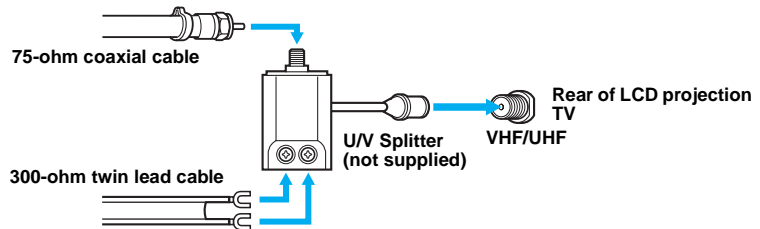

C VHF and UHF



 It is highly recommended to connect the antenna using a 75-ohm coaxial cable to get optimum picture quality. A 300-ohm twin lead cable can be easily affected by radio noise and the like, resulting in signal deterioration. If you use a 300-ohm twin lead cable, keep it away as far as possible from the LCD projection TV.

 Do not use an indoor antenna because it is especially susceptible to radio noise.

Cable and Antenna

If your cable provider does not feature local channels, you may find this set up convenient.

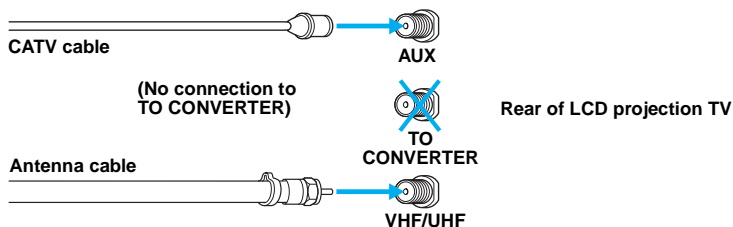

Select CABLE or antenna (ANT) mode by pressing ANT on the remote control.

 To receive channels with an antenna, you need to turn your Cable to Off (see page 76) and perform the Auto Program function (see page 76).

Cable Box Connections

Cable Box and Cable

This is the preferred basic cable TV hookup to use if:

- ❑ Your cable TV company scrambles some channels, but not all of them (pay channels vs. regular cable channels) and you need to use a cable box, and
- ❑ You want to enjoy the Twin View feature.

With this setup you can:

- ❑ Use the LCD projection TV remote control to change channels using your cable box when the signal is scrambled.
- ❑ Use the LCD projection TV remote control to change channels using your LCD projection TV when the signal is not scrambled. (Your LCD projection TV's tuner provides a better signal than the cable box.)
- ❑ Use the Twin View feature. (When all channels are routed through your cable box, only one channel is sent to the LCD projection TV, so you can not use the Twin View feature for your cable box.)

- 1 Connect the Cable TV cable to the LCD projection TV's VHF/UHF jack.
- 2 Using a coaxial cable, connect the LCD projection TV's TO CONVERTER jack to the cable box's IN jack. The LCD projection TV's internal converter allows you to switch between unscrambled signals coming straight into the LCD projection TV and scrambled signals coming in through the cable box, eliminating the need for an external splitter.

- Using a coaxial cable, connect the cable box's OUT jack to the LCD projection TV's AUX jack.

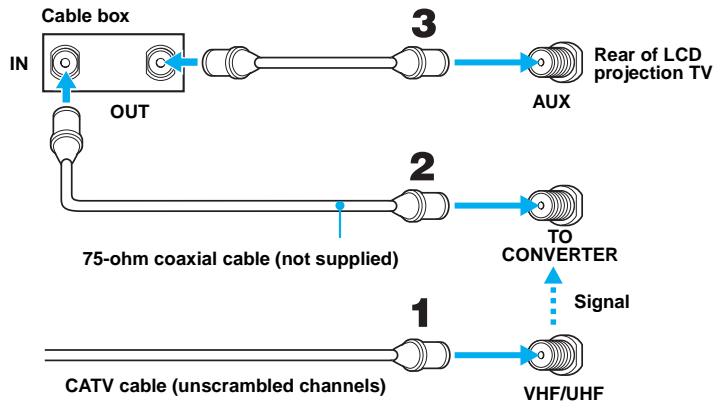

 Pressing ANT on the remote control switches between the channels coming in through the cable box (scrambled) and those coming directly to the TV (unscrambled).

Cable Box Only

Use this hookup if:

- ❑ You subscribe to a cable TV system that uses scrambled or encoded signals requiring a cable box to view all channels, and
- ❑ You do not intend to hook up any other audio or video equipment to your LCD projection TV.

When all channels are routed through your cable box, only one unscrambled channel is sent to the LCD projection TV, so you cannot use the Twin View feature. If some channels are scrambled, but others are not, consider using the hookup on page 26 instead.

- 1 Connect the coaxial connector from your cable service to the cable box's IN jack.
- 2 Using a coaxial cable, connect the cable box's OUT jack to the LCD projection TV's VHF/UHF jack.

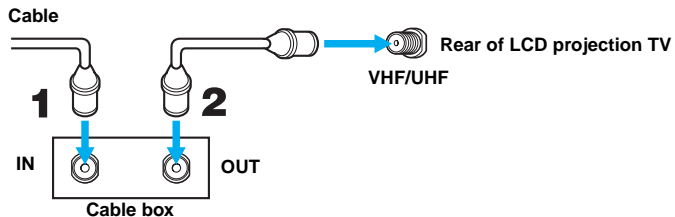

Also, set **Cable** to **On** in the Channel menu (see page 76).

- 🔧 Your Sony remote control can be programmed to operate your cable box (see “Programming the Remote Control” on page 86).
- 🔧 To change channels using the cable box, set your LCD projection TV to channel 3 or 4 depending on the cable box channel output. If you will be controlling all channel selection through your cable box, consider using the Channel Fix feature to set your LCD projection TV to channel 3 or 4 (see page 76).
- 💡 Setting the Channel Fix feature in the Channel menu (see “Using the Channel Menu” on page 76), ensures that you do not accidentally switch the channels using your LCD projection TV.

Connecting a VCR and Cable

Use this hookup if:

- You have cable TV that does not require a cable box.

Disconnect all power sources before making any connections.

- 1 Connect the cable TV cable to the VCR's IN jack.
- 2 Using a coaxial cable, connect the VCR's OUT jack to the LCD projection TV's VHF/UHF jack.
- 3 Using AUDIO and S VIDEO cables, connect the VCR's Audio and S Video OUT jacks to the LCD projection TV's AUDIO and S VIDEO IN jacks.

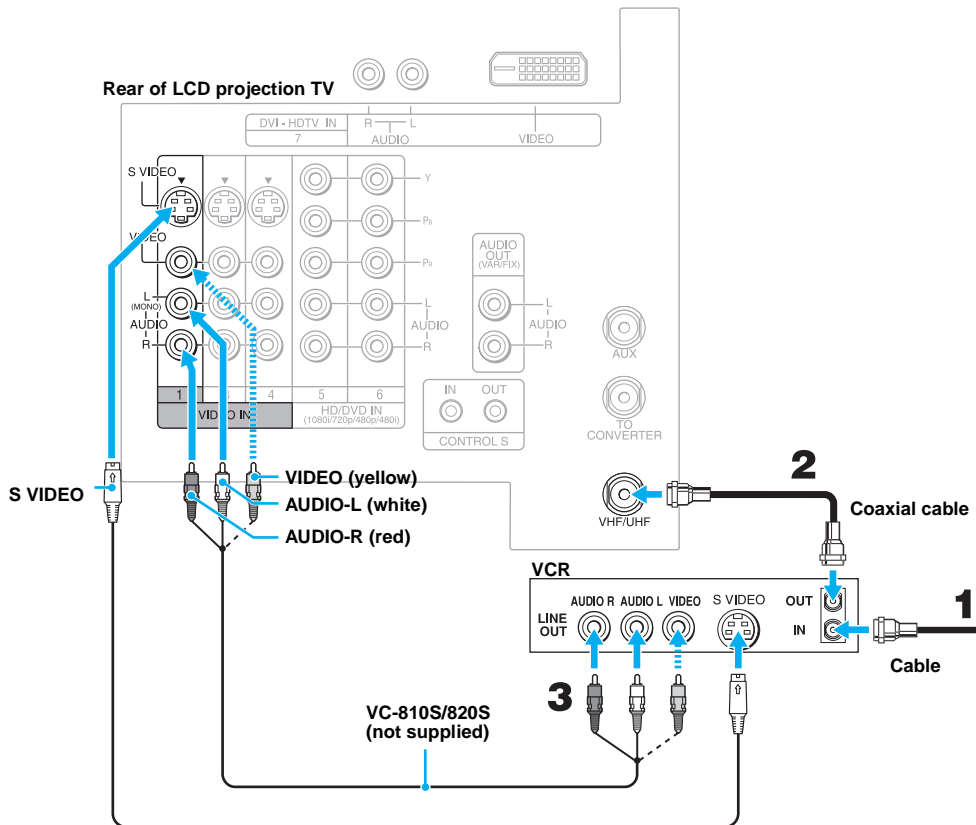

 If your VCR is not equipped with S VIDEO, use a VIDEO cable (yellow) instead of the S VIDEO cable.

Connecting a VCR and Cable Box

Use this hookup if:

- ❑ Your cable TV company scrambles some channels, but not all of them (pay channels vs. regular cable channels) and you need to use a cable box, and
- ❑ You want to enjoy the Twin View feature.

With this setup you can:



- ❑ Use the LCD projection TV remote control to change channels on your cable box when the signal is scrambled. To program your Sony remote control to operate your cable box, see “Programming the Remote Control” on page 86.
- ❑ Use the LCD projection TV remote control to change channels using your LCD projection TV when the signal is not scrambled. Your LCD projection TV’s tuner provides a better signal than the cable box.
- ❑ Use the Twin View feature. (When all channels are routed through your cable box, only one signal is sent to the LCD projection TV, so you cannot use the Twin View feature.)

Disconnect all power sources before making any connections.

- 1 Connect the Cable TV cable to the LCD projection TV’s VHF/UHF jack.
- 2 Using a coaxial cable, connect the LCD projection TV’s TO CONVERTER jack to the cable box’s IN jack. The LCD projection TV’s internal converter allows you to switch between unscrambled signals coming straight into the LCD projection TV and scrambled signals coming in through the cable box, eliminating the need for an external splitter.
- 3 Using a coaxial cable, connect the cable box’s OUT jack to the VCR’s IN jack.
- 4 Using AUDIO and S VIDEO cables, connect the VCR’s AUDIO and S VIDEO OUT jacks to the LCD projection TV’s AUDIO and S VIDEO IN jacks.
- 5 Using a coaxial cable, connect the VCR’s OUT jack to the LCD projection TV’s AUX jack.

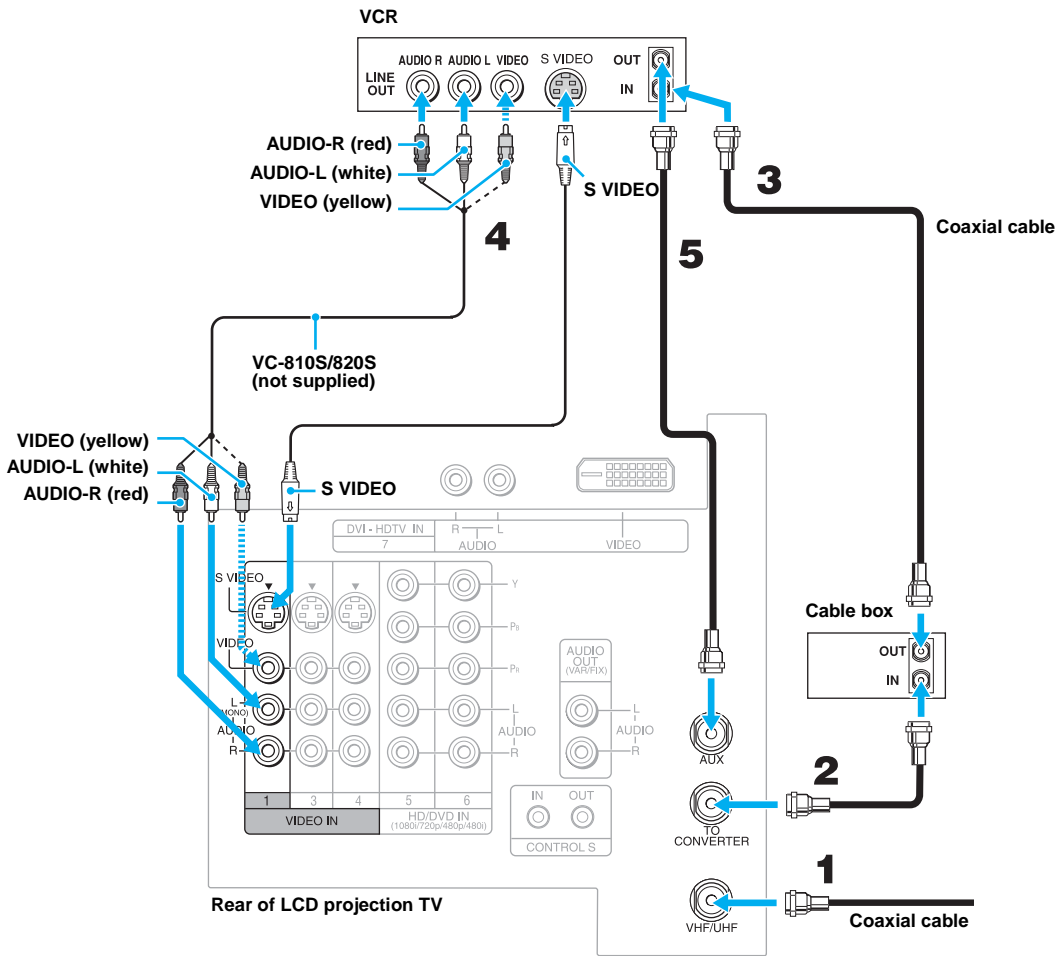
 To view scrambled channels, set your LCD projection TV to AUX 3 or 4 (depending on your cable box output). Change channels using your cable box.



-  If your VCR is not equipped with S VIDEO, use a VIDEO cable (yellow) instead of the S VIDEO cable.
-  You will not be able to change channels on the VCR. Set your LCD projection TV and VCR to channel 3 or 4, depending on your cable box channel output.
-  Pressing ANT on the remote control switches between the channels coming in through the cable box (scrambled) and those coming directly to the LCD projection TV (unscrambled).

Connecting Two VCRs for Tape Editing

If you connect two VCRs, you can record from one VCR to the other while using your LCD projection TV to monitor what is being recorded.

Disconnect all power sources before making any connections.

- 1 Using AUDIO and VIDEO cables, connect the playback VCR's Audio and Video OUT jacks to the recording VCR's Audio and Video IN jacks.
- 2 Using AUDIO and VIDEO cables, connect the recording VCR's AUDIO and Video OUT jacks to the LCD projection TV's AUDIO and VIDEO IN jacks.

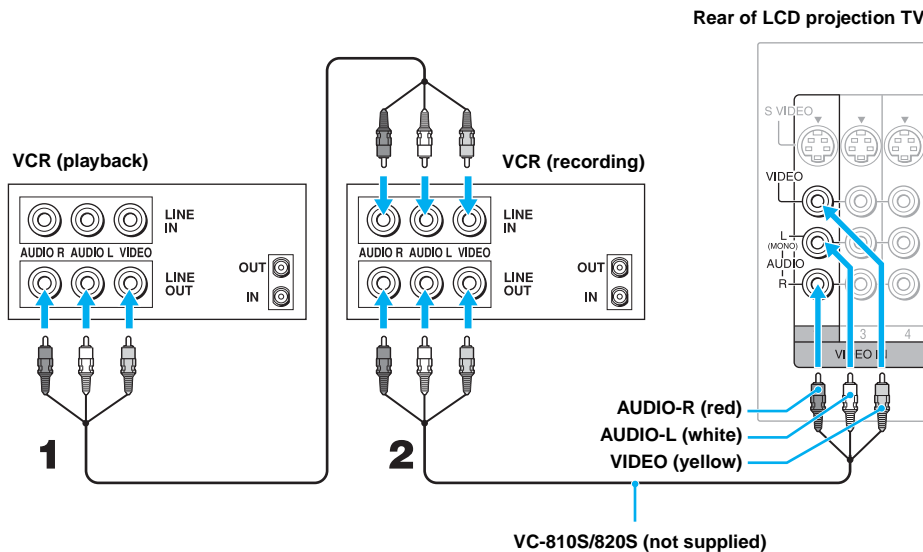

- 🔧 To perform tape editing, set the LCD projection TV to the video input intended for playback by pressing TV/VIDEO on the remote control.
- 🔧 You may need to change the video input on your VCR. Consult your VCR's operating manual for instructions.
- 🔧 If your VCRs have an S VIDEO jack: For best picture quality, use an S VIDEO connection instead of the yellow video cable on your combined A/V cable. Using an S VIDEO cable, connect the playback VCR's S VIDEO OUT jack to the recording VCR's S VIDEO IN jack. S VIDEO does not provide audio, so audio cables must be connected to provide sound.
- 🔧 You cannot record signals from equipment connected to the Y, P_B, P_R input.

Connecting a Satellite Receiver

Disconnect all power sources before making any connections.

- 1 Connect the satellite antenna cable to the satellite receiver's SATELLITE IN jack.
- 2 Using AUDIO and S VIDEO cables, connect the satellite receiver's AUDIO and S VIDEO OUT jacks to the LCD projection TV's AUDIO and S VIDEO IN jacks.
- 3 Connect a coaxial cable from your cable or antenna to the LCD projection TV's VHF/UHF jack.

 If your satellite receiver is not equipped with S VIDEO, use a VIDEO cable (yellow) instead of the S VIDEO cable.

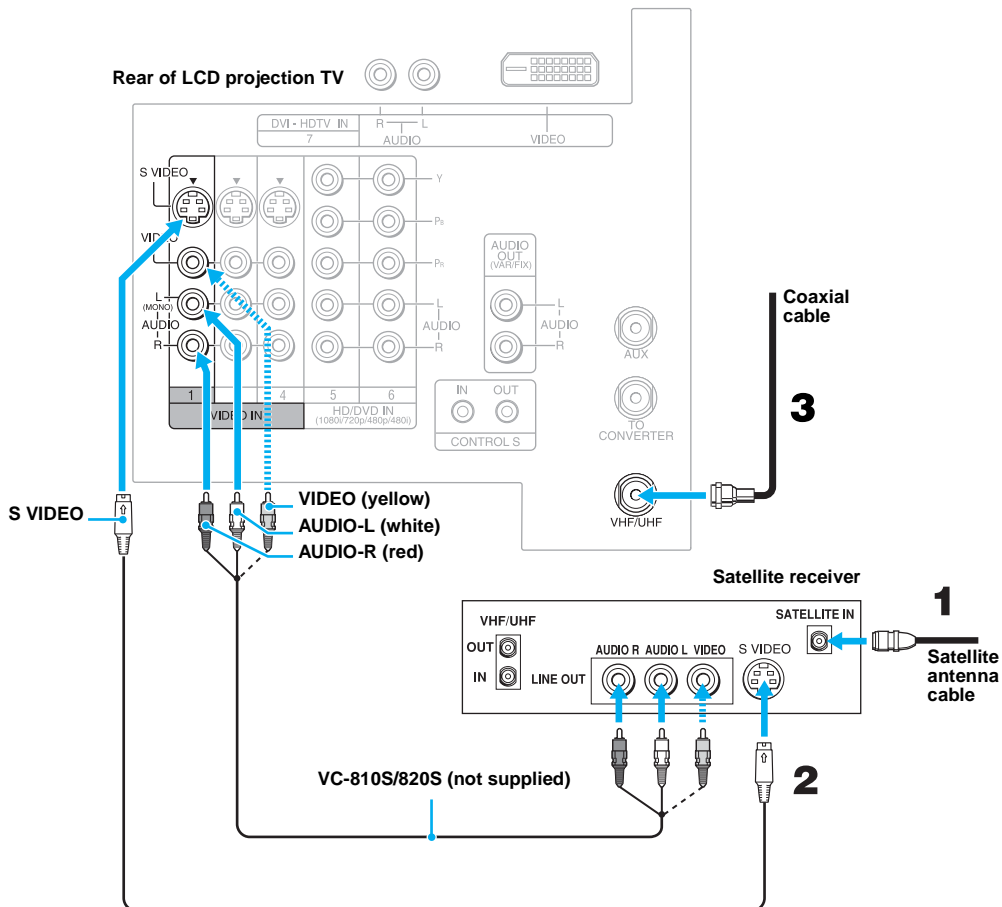

Connecting a Satellite Receiver with a VCR

Disconnect all power sources before making any connections.

- 1 Connect the satellite antenna cable to the satellite receiver's SATELLITE IN jack.
- 2 Connect the CATV cable to the VCR's VHF/UHF IN jack.
- 3 Using a coaxial cable, connect the VCR's OUT jack to the LCD projection TV's VHF/UHF jack.
- 4 Using AUDIO and S VIDEO cables, connect the satellite receiver's AUDIO and S VIDEO OUT jacks to the VCR's AUDIO and S VIDEO IN jacks.
- 5 Using AUDIO and S VIDEO cables, connect the VCR's AUDIO and S VIDEO OUT jacks to the LCD projection TV's AUDIO and S VIDEO IN jacks.

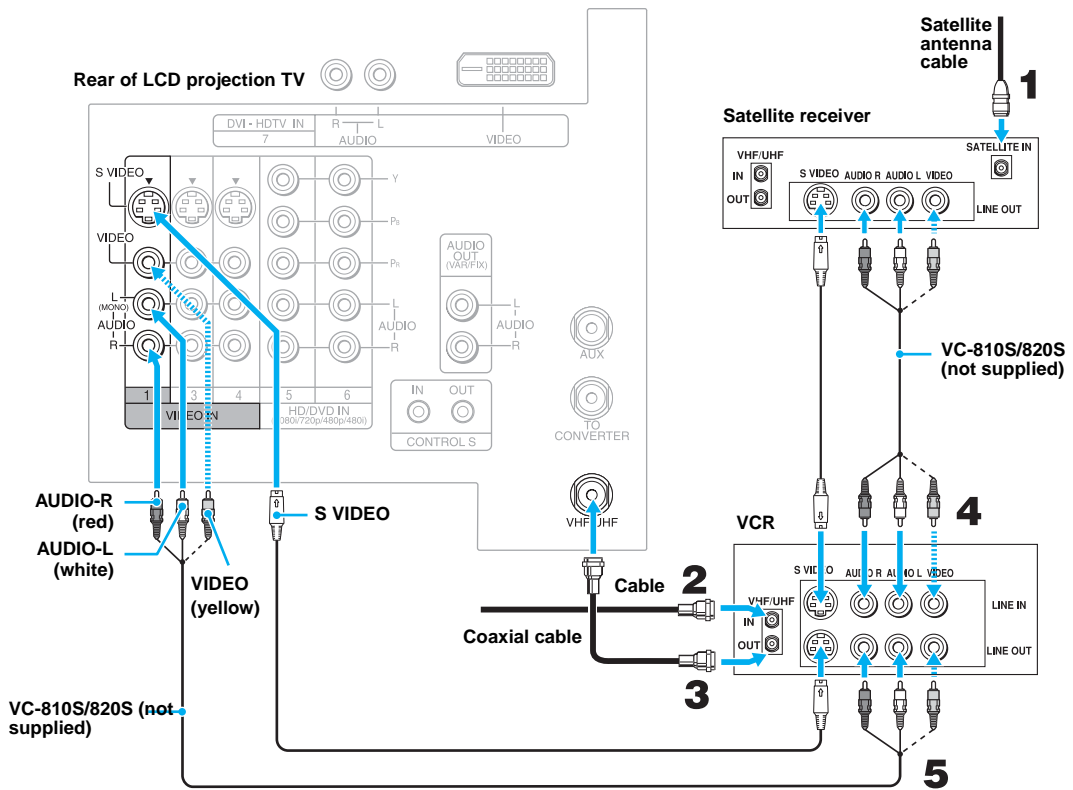

- ✎ Be sure your VCR's video input is set correctly. Consult your VCR's operating manual for instructions.
- ✎ Use TV/VIDEO to select
 - VIDEO 1 to watch satellite TV or the VCR (your VCR must be turned on).
 - VHF/UHF to watch cable TV.
- ✎ If your VCR or satellite receiver is not equipped with S VIDEO, use a VIDEO cable (yellow) instead of the S VIDEO cable.

Connecting an Audio Receiver

Disconnect all power sources before making any connections.

Using audio cables, connect the LCD projection TV's AUDIO OUT (VAR/FIX) jacks to the audio receiver's audio LINE IN jacks.

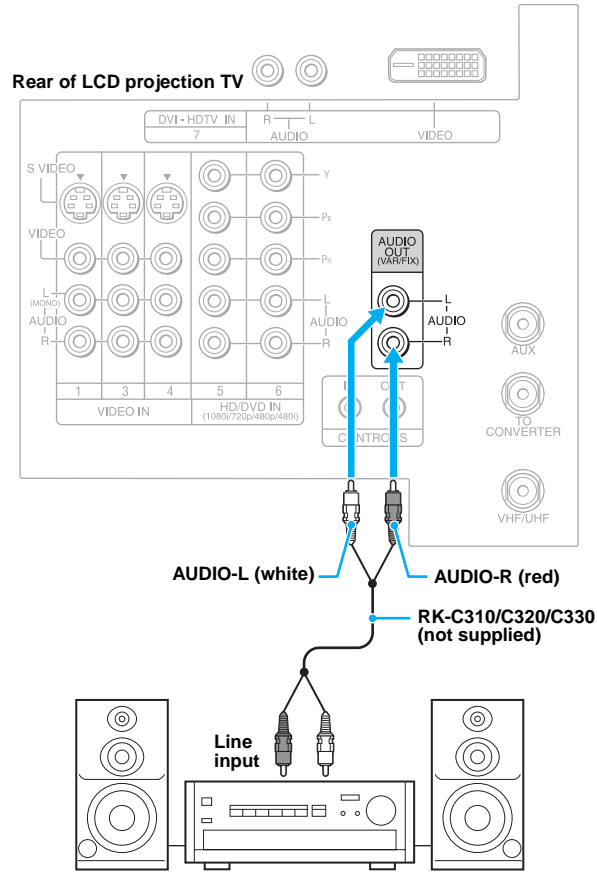

Connecting a DVD Player with Component Video Connectors

This is the preferred hookup to use if:

- Your DVD player has component (Y, B-Y, R-Y) jacks.

Disconnect all power sources before making any connections.

- Using three separate component video cables, connect the DVD player's Y, B-Y and R-Y jacks to the Y, PB and PR jacks on the LCD projection TV. Use the HD/DVD IN 5 or 6 connections.

 The Y, B-Y and R-Y jacks on your DVD player are sometimes labeled Y, C_B and C_R, or Y, P_B and P_R. If so, connect the cables to like colors.

- Using an audio cable, connect the DVD player's Audio OUT jacks to the LCD projection TV's AUDIO IN jacks. Be sure to use the same row of inputs that you used for the video connection (HD/DVD IN 5 or 6).

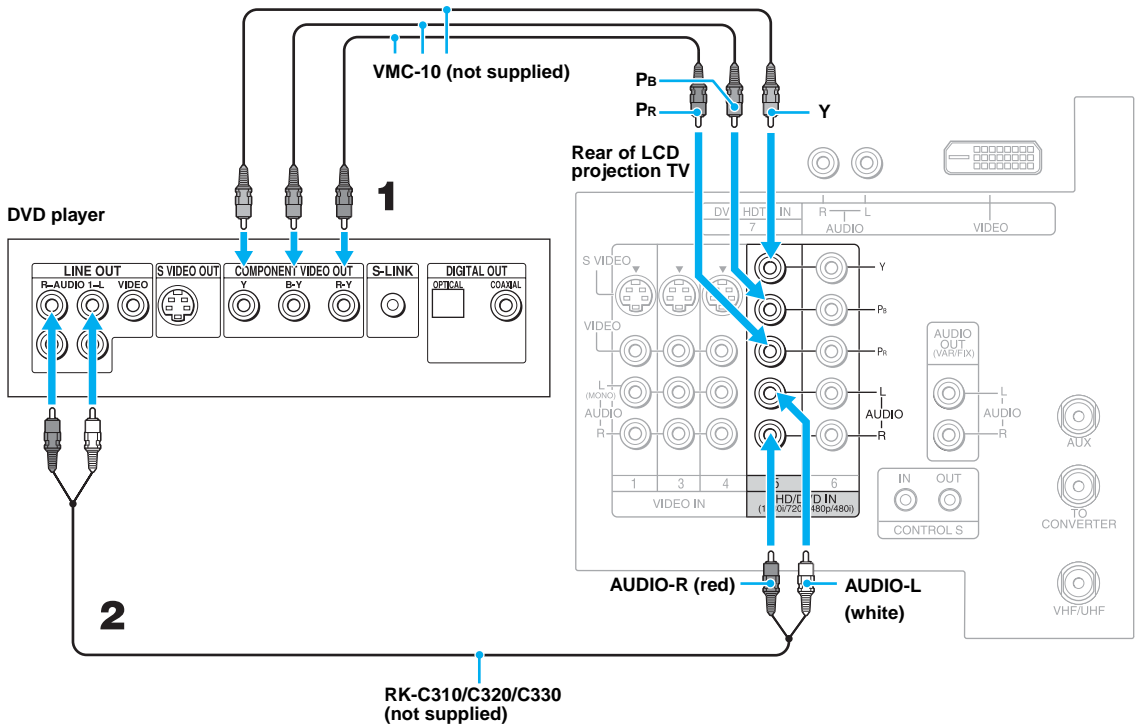

 To take advantage of the Wide Screen modes, set the TV's aspect ratio to 16:9 on your DVD player. For details, refer to the operating instructions supplied with your DVD player.

Connecting a DVD Player with A/V Connectors

Use this hookup if:

- ❑ Your DVD player does not have component (Y, PB, PR) jacks.

🔧 If your DVD player has video component output connectors: for best picture quality use the connection described on page 37.

Disconnect all power sources before making any connections.

- 1 Using audio cables, connect the DVD player's Audio OUT jacks to the LCD projection TV's AUDIO IN jacks.
- 2 Using an S VIDEO cable, connect the DVD player's S VIDEO jack to the LCD projection TV's S VIDEO jack.

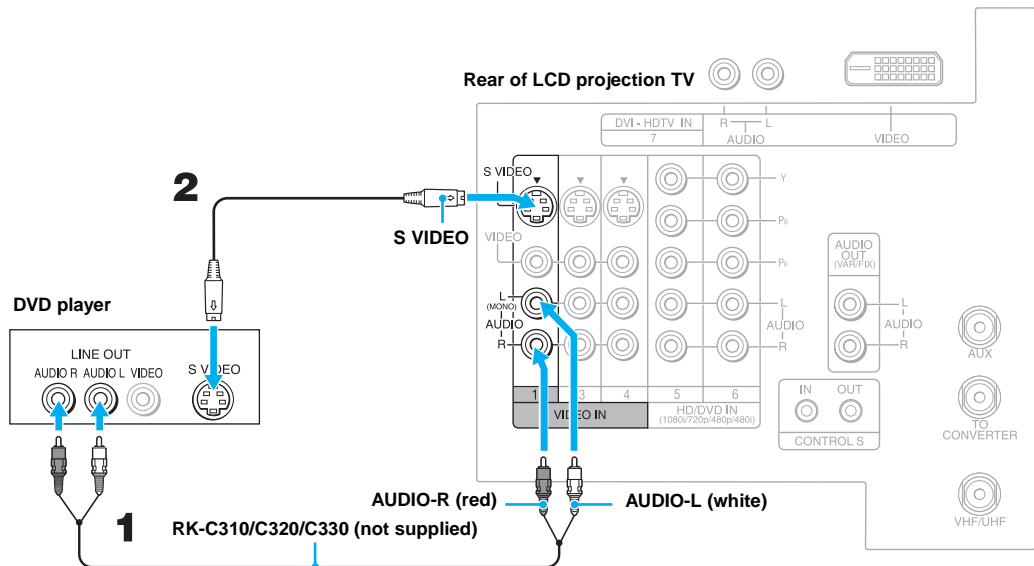

🔧 To take advantage of the Wide Screen modes, set the TV's aspect ratio to 16:9 on your DVD player. For details, refer to the operating instructions supplied with your DVD player.

🔧 Use TV/VIDEO on the remote control to switch between the VCR, DVD player and cable TV inputs.

🔧 If your VCR is not equipped with S VIDEO, use a VIDEO cable (yellow) instead of the S VIDEO cable.

Connecting a Digital TV Receiver with component connectors

Disconnect all power sources before making any connections.

 Be sure to read the Set-top box manual.

1 Using three separate component video cables, connect the Digital TV Set-top box's Y, P_B and P_R jacks to the LCD projection TV.

 The Y, P_B and P_R jacks do not provide audio, so audio cables must be connected to provide sound.

 Component video connection is necessary to view 480i, 480p, 720p, and 1080i formats. You may also use the S VIDEO or Composite Video connections, however, component video (Y, P_B, P_R) will provide the best picture quality for all format types.

2 Using an audio cable, connect the Digital TV Set-top box's Audio OUT jacks to the LCD projection TV's AUDIO IN jacks.

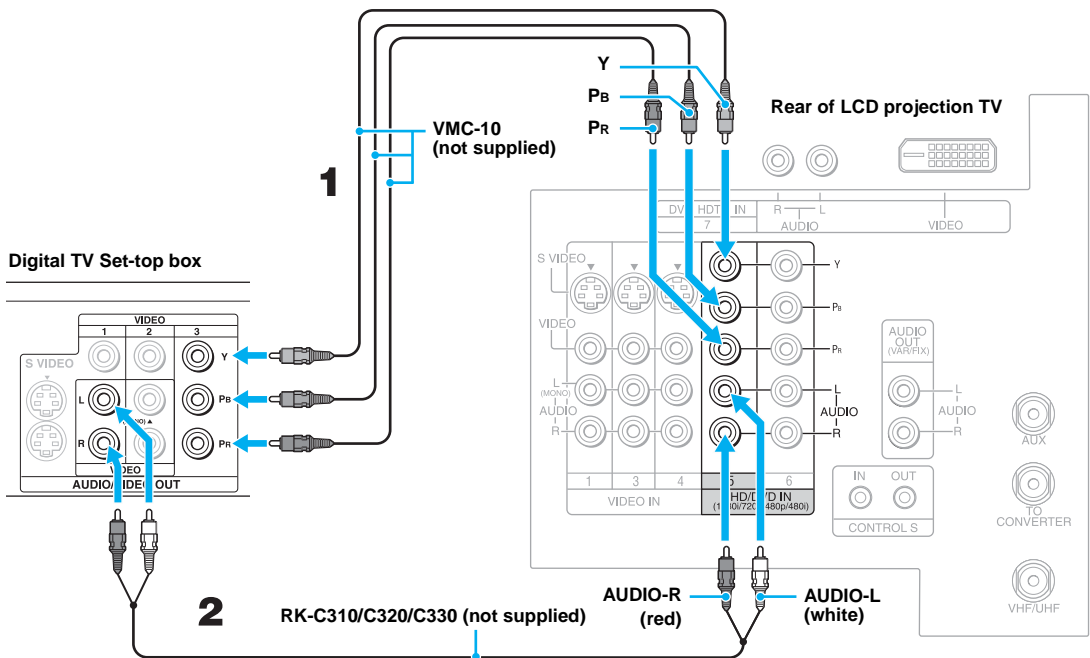

 You cannot record the signal from any equipment connected into the Y, P_B and P_R connectors.

 This LCD projection TV is not compatible with digital TV receivers configured with RGB or VGA output connectors.

Connecting a Digital TV Receiver with DVI-HDTV connector

Disconnect all power sources before making any connections.

 Be sure to read the Set-top box manual.

- 1 Using a DVI-D single link cable, connect the Digital TV Set-top box's DVI-HDTV connector to the LCD projection TV.

 The DVI-HDTV VIDEO connector does not provide audio, so audio cables must be connected to provide sound.

- 2 Using an audio cable, connect the Digital TV Set-top box's Audio OUT jacks to the LCD projection TV's DVI-HDTV AUDIO jacks.

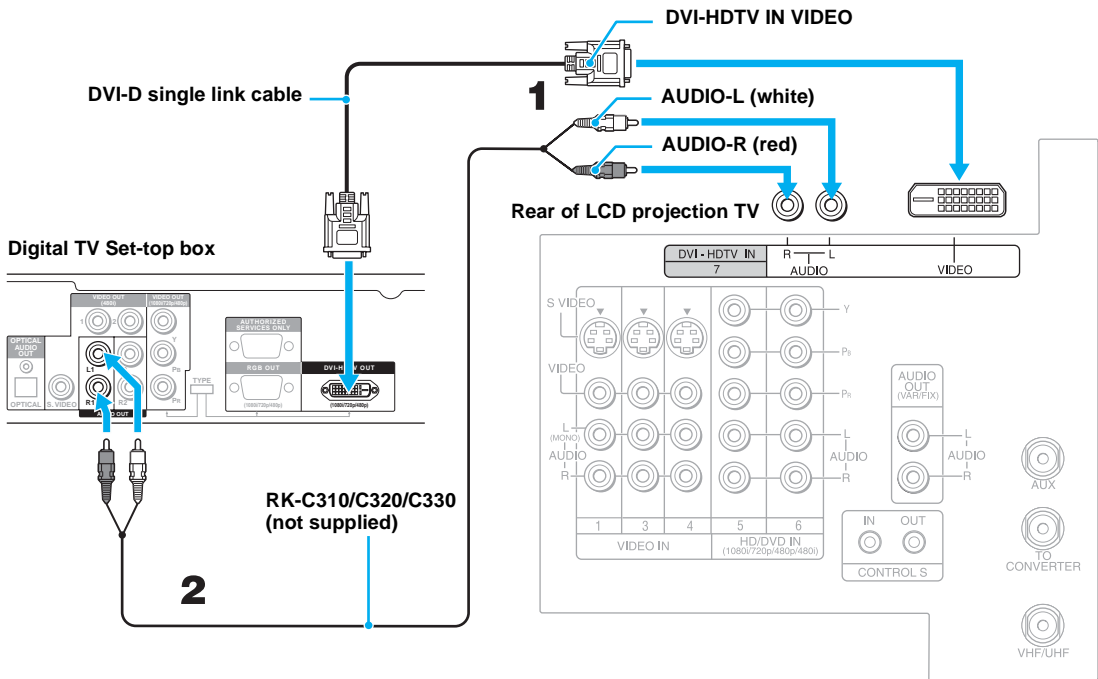

Connecting a Camcorder

For easy connection of the camcorder, the LCD projection TV has front Audio and Video inputs (shown below). However, if you prefer, you can also connect the camcorder to the LCD projection TV's rear Audio and Video IN jacks.

Using AUDIO and S VIDEO cables, connect the camcorder's Audio and S VIDEO OUT jacks to the LCD projection TV's AUDIO and S VIDEO IN jacks.

- ✎ If you have a mono camcorder, connect its left audio output to the LCD projection TV's AUDIO L (MONO) jack.
- ✎ If your camcorder is not equipped with S VIDEO, use a VIDEO cable (yellow) instead of the S VIDEO cable.

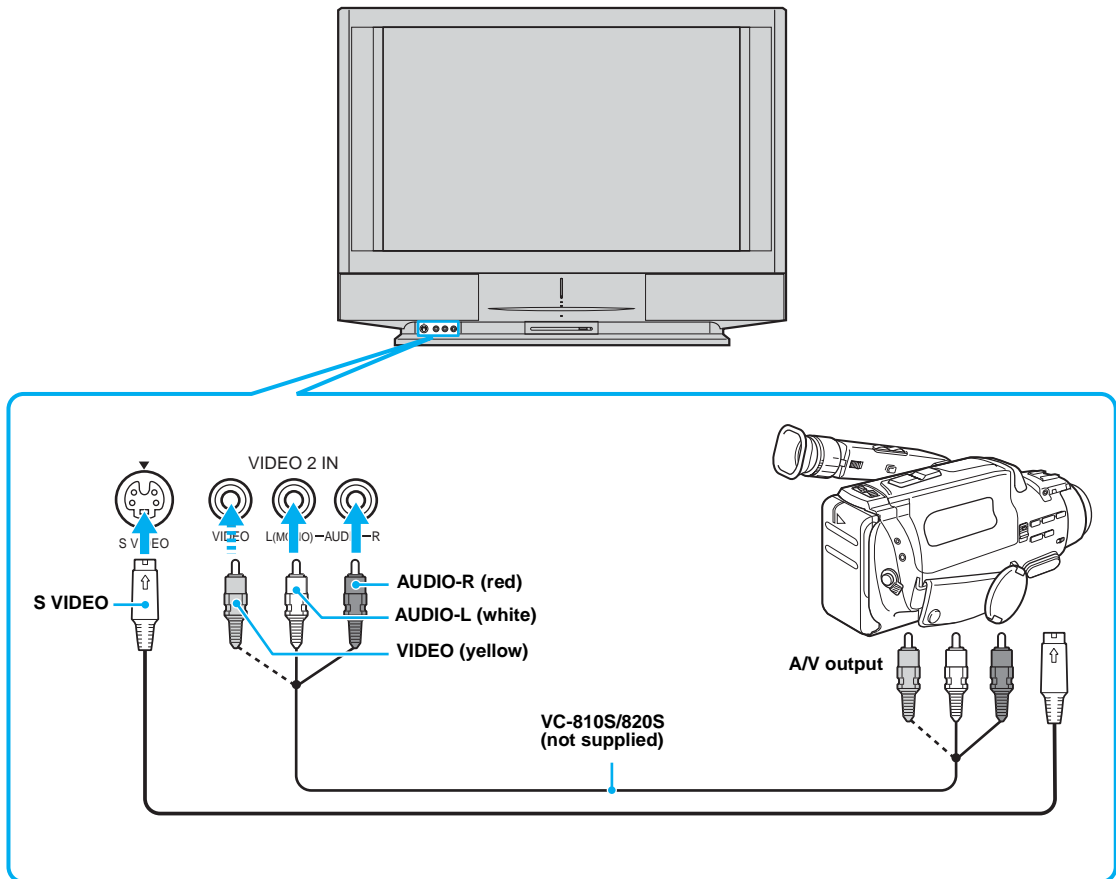

Using the CONTROL S Feature

CONTROL S allows you to control your LCD projection TV system and other Sony equipment with one remote control. In addition to allowing you to control multiple devices with one remote control, the CONTROL S feature allows you to always point your remote control at your LCD projection TV, instead of having to point it at the other equipment, which might be hidden or out of direct line of sight.

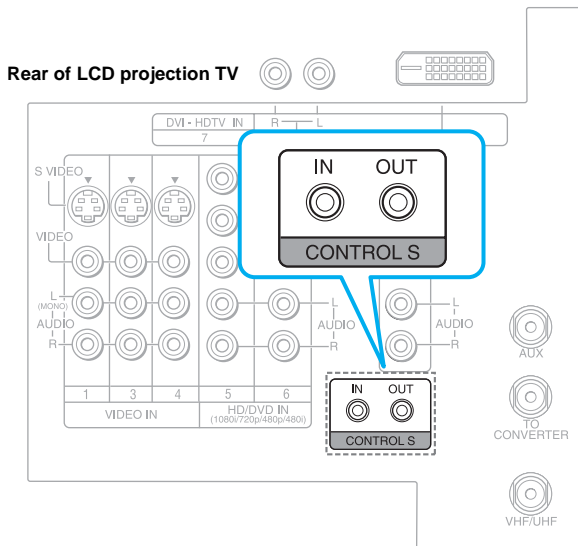

Setting Up the LCD projection TV Automatically

After you finish connecting your LCD projection TV, you can run Auto Setup to set up your channels. The Auto Setup screen appears when you turn your LCD projection TV on for the first time after installing it. If you do not want to set up the channels at this time, you can do it later by using the Auto Program feature in the Channel menu (see page 76).

 The Auto Setup feature does not apply for installations that use a cable box for all channel selection.

Using Auto Setup

- 1 Press POWER on the front panel of your LCD projection TV or on the remote control to turn on the LCD projection TV.
- 2 Press FUNCTION on the remote control until the TV indicator lights up.
- 3 Press CHANNEL+ on your LCD projection TV to run Auto Setup, or press CHANNEL- to exit. If you use the channel buttons on your remote control, be sure to use .

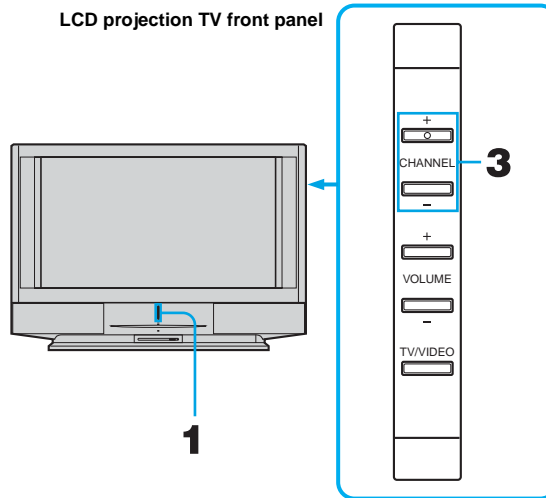

 You can run Auto Program by selecting it in the Channel menu, as described on page 76.

Using the Features

Using the Remote Control



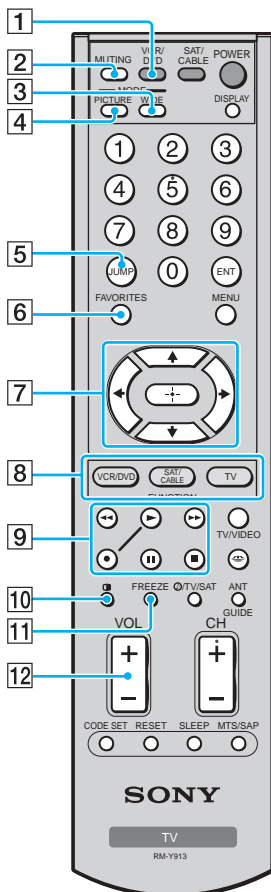

The following table describes the buttons on the remote control that are for more advanced functions.

Button Descriptions

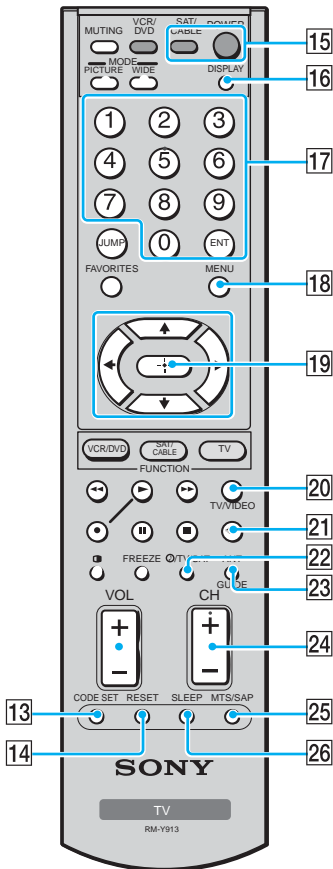

Button	Description
1	VCR/DVD Press to turn on and off the VCR or DVD player.
2	MUTING Press to mute the sound. Press again or press VOL + to restore the sound.
3	WIDE MODE Press to step through the wide screen modes: Wide Zoom, Normal, Full and Zoom. For details, see “Using Wide Screen Mode” on page 54.
4	PICTURE MODE Press repeatedly to step through the available video picture modes: Vivid, Standard and Pro Mode. Also available in the Video menu. For details, see “Selecting Video Options” on page 69.
5	JUMP Press to jump back and forth between two channels. The LCD projection TV alternates between the current channel and the last channel that was selected.
6	FAVORITES Displays the Favorite Channels list. For details, see “Using Favorite Channels” on page 49.
7	↑/↓/←/→ When the menu is displayed, move the on-screen cursor.
8	FUNCTION Select the equipment (TV, SAT/CABLE, VCR/DVD) that you want to operate.
9	 : Pause ■ : Stop ◀◀ : Rewind ▶▶ : Play ▶▶▶ : Fast-Forward ● : Record by pressing ● and ▶
10	TWIN VIEW Turns on/off Twin View. For details, see “Using Twin View™” on page 50.
11	FREEZE Freezes the window picture. Press again to restore the picture.
12	VOL +/- Adjusts the volume.



Button	Description
13 CODE SET	Use for programming the remote control to operate non-Sony video equipment. For details, see “Programming the Remote Control” on page 86.
14 RESET	Press when in a menu to reset the settings to the factory defaults.
15 POWER buttons (GREEN)	Turn on and off the LCD projection TV and other audio/video equipment you have programmed into the remote control. For instructions, see “Programming the Remote Control” on page 86.
16 DISPLAY	Press once to display the current time and channel label (if set) and channel number. Press again to turn Display off. See page 84 for details on setting the time.
17 0 – 9 and ENT	Press 0 - 9 to select a channel, the channel changes after 2 seconds. Press ENT to select immediately.
18 MENU	Press to display the LCD projection TV on-screen menu. Press again to exit from the menu.
19 	When the menu is displayed, select the item.
20 TV/VIDEO	Cycles through the video equipment connected to your LCD projection TV’s video inputs: TV, VIDEO 1, VIDEO 2, VIDEO 3, VIDEO 4, VIDEO 5, VIDEO 6 and VIDEO 7.
21 MEMORY STICK 	Press to display the Memory Stick Menu. For details, see “Using the Memory Stick Viewer” on page 55.
22 	Press to scroll an audio option: TruSurround, Simulated, and Off.
TV/SAT	Press to select the TV or satellite receiver.
23 ANT GUIDE	Changes between the VHF/UHF input and the AUX input. Displays the program guide of your satellite.
24 CH +/-	Scan through channels.  To scan rapidly through the channels, press and hold down CH+ or CH-.
25 MTS/SAP	Press to scroll through the Multi-channel TV Sound (MTS) options: Stereo, Auto SAP, and Mono.
26 SLEEP	Press repeatedly until the LCD projection TV displays the time in minutes (15, 30, 45, 60, or 90) that you want the LCD projection TV to remain on before shutting off automatically. To cancel Sleep timer, press SLEEP repeatedly until SLEEP OFF appears. Pressing down POWER also cancels the Sleep timer and turns off the power. While the Sleep feature is set, press once to view the remaining time.

Watching the TV

Many TV features can be accessed directly through the remote control. The following will explain the function of some of the buttons found on your remote control.

Buttons for LCD Projection TV Operations

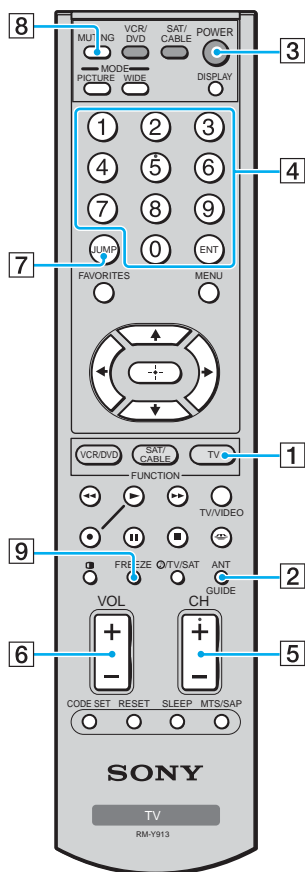

1 FUNCTION TV

Press to have the remote control operate the TV. The indicator lights up momentarily when pressed to show which equipment the remote control is operating.

2 ANT— (AUX input)

Press to change between the VHF/UHF input and the AUX input.

3 POWER

Turn the LCD projection TV on and off. If a video input indication (e.g., VIDEO 1, VIDEO 2) appears on the screen, press TV/VIDEO or CH +/- until a channel number appears.

4 0-9 and ENT

Use for direct channel selection. Press 0-9 to select a channel (for example, to select channel 10, press 1 and 0). The channel will change after 2 seconds, or you can press ENT for immediate selection.

5 CH +/-

Press to scan through the channels (+ up or – down).

6 VOL +/-

Press to adjust the volume (+ up or – down).

7 JUMP

Press to alternate or jump back and forth between two channels. The LCD projection TV will jump between the current channel and the last channel selected.

8 MUTING

Press to mute the sound. “MUTING” will appear on the screen. To restore the sound, press again or press VOL +.

9 FREEZE

This is useful when you need to copy down information that appears on the LCD projection TV’s screen (see “Using the Freeze Function” on page 53).

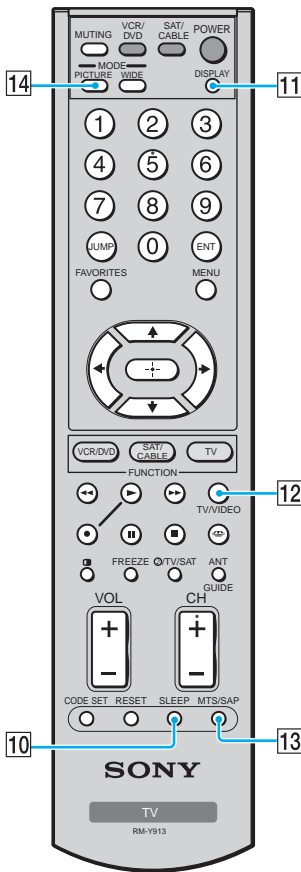
**10 SLEEP**

Press repeatedly until the LCD projection TV displays the approximate time in minutes (15, 30, 45, 60, or 90) that you want the LCD projection TV to remain on before shutting off automatically.

Cancel by pressing SLEEP until “SLEEP OFF” appears.

11 DISPLAY

Press to display the channel number, current time and channel label (if set).

To turn the display off, press DISPLAY again.

12 TV/VIDEO

Press repeatedly to scroll through available video inputs: TV, VIDEO 1, VIDEO 2, VIDEO 3, VIDEO 4, VIDEO 5, VIDEO 6 and VIDEO 7.

If you select Skip as a Video Label in the Setup menu, your LCD projection TV will skip the video input you selected (see “Video Label” on page 83).

13 MTS/SAP

Press to scroll through the Multi-channel TV Sound (MTS) options (see “MTS” on page 72).

14 PICTURE MODE

Press PICTURE MODE repeatedly to directly choose one of three different video modes that best suits the program you are watching.

Vivid: Select for enhanced picture contrast and sharpness.

Standard: Select to display a standard picture for normal viewing environments.

Pro: Select to display a picture with minimum enhancements.

When you select each mode, you can also adjust the picture quality (such as Brightness, Color, etc.) to suit your taste. For details, see “Mode” on page 69.

Watching Digital TV

When you have connected the DTV receiver, you can enjoy digital TV programs. This LCD projection TV is capable of receiving the 1080i, 720p, 480p and 480i digital TV formats.

To view a digital TV program

- 1 Connect the DTV receiver to DVI-HDTV IN 7, HD/DVD IN 5 or 6 on the LCD projection TV (for details, see page 39).
- 2 Press TV/VIDEO to select DVI-HDTV IN 7, HD/DVD IN 5 or 6.
- 3 Select a digital channel on the DTV receiver. For details, see the Operating Manual of the DTV receiver.
- 4 Adjust the volume of the LCD projection TV as necessary.

Using Favorite Channels

The Favorite Channel feature lets you select programs from a list of favorite channels that you preset.



Creating a List of Favorite Channels

- 1 Press MENU to display the Menu.
 - 2 Press ◀ or ▶ to highlight the Channel icon and press (+).
 - 3 Press (+) to select Favorite Channels.
 - 4 Press ▲ or ▼ to highlight a Favorite Channel number (1-16) and press (+).
 - 5 Press ▲ or ▼ to highlight a channel you want to assign to the Favorite Channel number. A preview of the highlighted channel appears in the upper right of the screen.
Press (+) to select that channel as a Favorite Channel.
 - 6 To add more channels to your favorites list, repeat steps 4-5.
To clear a Favorite Channel, press ▲ or ▼ to highlight the channel you want to clear. Press (+) and then press RESET.
 - 7 Press MENU to exit the Menu.
-  For details on using the Channel Menu, see page 76.

Displaying a List of Favorite Channels

- 1 Press FAVORITES.
The Favorite Channel options appear.



- 2 Press ▲ or ▼ to highlight the channel you want to watch. The program of that channel appears in the preview window. Press (+) to select.
-  When the remote control function is set to other than TV function, you can display the Favorite Channels. However, you cannot select the channel by using ▲ or ▼.
-  To assign Channel Labels (e.g., ABC, HBO, MTV, etc.) to channel numbers, as shown at right, use the Channel Label feature in the Channel Menu (see page 77).

Using Twin View™

Twin View enables you to watch two programs at the same time. You can also change the size of both the left and right pictures.



Activating Twin Pictures

To display twin pictures



- 1 Make sure your LCD projection TV is tuned to a working channel.
- 2 Press .



To cancel twin pictures

- Press  again (or press .

Activating the Picture

Although two pictures appear on the screen at the same time, only one picture is active. Change the picture size by using the  or  button. For an active picture, you can:

- Change channels.
- Adjust the volume.
- Switch the input sources from VHF/UHF to cable by pressing ANT or TV/VIDEO to switch the video input.

To activate the right picture

- Press .



To activate the left picture

- Press .

 Hookups that affect your ability to use Twin View:

- If you are viewing all channels through the cable box, the Twin View feature will not work. The cable box only unscrambles one signal at a time, so the right picture will be the same as the left picture.
- You can watch a scrambled cable channel and another video source. Be sure your DVD player, VCR or satellite receiver are connected to one of the VIDEO IN 1-7 and AUX inputs on the rear of the LCD projection TV. Pictures from equipment connected to HD/DVD IN 5 and 6, DVI-HDTV IN 7, and AUX will only appear in the left picture, not in the right.

Factors Affecting Twin View

- ❑ If you use a cable box to view all channels, the same channel appears in both windows because the cable box unscrambles only one channel at a time.
- ❑ If you use a cable box, you can view the cable box output in one window and view a different source (such as a VCR or DVD player) in the second window by using the TV/VIDEO button.
- ❑ Sources connected to the AUX, VIDEO 5, VIDEO 6, and VIDEO 7 inputs display in the left window, but not the right.
- ❑ If you are viewing a 4:3 source and a 16:9 enhanced source (such as a DVD) side by side, the 4:3 source appears larger.
- ❑ Twin View does not display channels that are blocked by parental settings (see page 78).

Changing the Picture Size

The zoom feature lets you change the size of the left and right pictures.

To enlarge the left picture (reduce the right)

- 1 Press ← to activate the left picture (if not already activated).
- 2 Press ↑ to enlarge the picture and ↓ to reduce the picture.

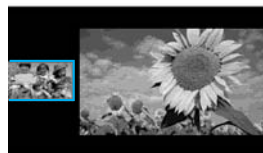
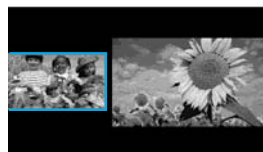
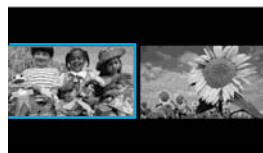
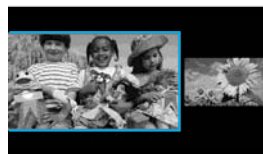

To enlarge the right picture (reduce the left)

- 1 Press → to activate the right picture (if not already activated).
- 2 Press ↑ to enlarge the picture and ↓ to reduce the picture.

📌 When you adjust the twin screen sizes, the LCD projection TV memorizes the change. The next time you use the Twin View function, the memorized sizes appear.

Using the Freeze Function

The FREEZE button allows you to temporarily capture a program's picture. You can use this feature to write down information such as phone numbers, recipes, etc.

To use the Freeze function

- 1 When the program information you want to capture is displayed, press FREEZE.
- 2 The LCD projection TV switches to Twin View mode and displays the "frozen" picture on the right, while the current program continues on the left.

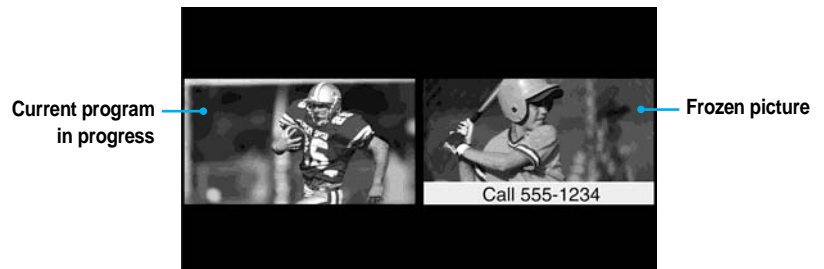

- 3 To cancel and return to normal viewing, press FREEZE.

 Freeze feature is not available if you are already in Favorite Channel (see page 49) or Twin View™ (see page 50).

Using Wide Screen Mode

Wide Screen Mode lets you watch 4:3 normal broadcasts in several Wide Screen Modes (16:9 aspect ratio).

- Press WIDE MODE repeatedly to toggle through the following Screen Mode settings.

 You can also access the Screen Mode settings in the Screen menu. For details, see page 74.



Wide Zoom



Normal



Full



Zoom

Wide Zoom enlarges the 4:3 picture to fill the 16:9 screen, keeping the original image as much as possible.

Normal returns the 4:3 picture to its original size.

Full Mode stretches the 4:3 picture horizontally only, to fill the 16:9 screen.

Zoom Mode enlarges the 4:3 picture horizontally and vertically to an equal aspect ratio that fills the 16:9 screen. Useful for watching Letterbox movies.

 When you change channels or inputs, the Screen Mode settings revert to Wide Zoom (or the 4:3 Default setting in the Wide menu). To retain the current Screen Mode setting as channels and inputs are changed, set 4:3 Default to Off. For details, see page 75.

Using the Memory Stick Viewer

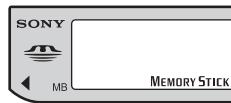

About Memory Stick

Memory Stick (sold separately) is a new, compact, portable, and versatile Integrated Circuit recording medium with a data capacity that exceeds that of a floppy disk. Memory Stick is specially designed for exchanging and sharing digital data among Memory Stick compatible products such as digital cameras and digital video cameras. Because it is removable, Memory Stick can also be used for external data storage.



The Memory Stick Viewer on your LCD projection TV allows you to view still images (JPEG files) and movies (MPEG1 files) stored on Memory Stick media.

For more information about using Memory Stick media, see “Notes on Using Memory Stick, Memory Stick PRO Media” on page 90.

 "Memory Stick", "Memory Stick PRO", "Memory Stick Duo" and " " are registered trademarks of Sony Corporation.

Supported Image Types

This LCD projection TV's Memory Stick viewer can display still images and movies that have been recorded on Memory Stick media.

You can view:

- ❑ Image files compressed in the JPEG format (DCF compliant) (with an extension, .jpg)
- ❑ MPEG1 files, MPEG MOVIE, MPEG MOVIE AD, MPEG MOVIE EX, MPEG MOVIE HQ, MPEG MOVIE HQX, MPEG MOVIE CV, VAIO Giga Pocket MPEG1.

(Continued)

- ✎ JPEG stands for “Joint Photographic Experts Group,” which is the organization that implemented this format. DCF stands for “Design Rules for Camera File Systems,” which are specifications established by the Japan Electronic Industry Development Association (JEIDA).
- ✎ MPEG1 stands for “Motion Picture Experts Group” which is the organization that implemented this format and is the typical compression format for movie files.

About Directory and File Names

Most Sony brand digital still and video cameras automatically record still images using DCF compliant directory and file names, or record movies using the directory and file names as shown in the following examples:

Still image files

Example:

Directory Name: /DCIM/100MSDCF

File Name: DSC00001.JPG

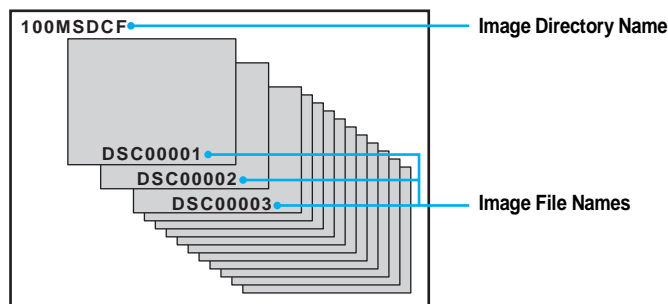

Movie files

Example:

Directory Name: /MSSONY/MOML0001

File Name: MOV00001.MPG

Unsupported Image Types

This LCD projection TV’s Memory Stick viewer cannot display any of the following:

- ❑ Images stored in TIFF or any other non-JPEG or non-MPEG compression format
- ❑ Images with less than 16 horizontal and/or vertical dots per line
- ❑ Images with more than 4096 horizontal and/or vertical dots per line
- ❑ An image processed by a computer may not be displayed correctly.

Inserting and Removing a Memory Stick

To insert a Memory Stick

- 1 Locate the Memory Stick slot (see page 21) and insert the Memory Stick into the Memory Stick slot as illustrated below. When inserted properly, it should slide in with little resistance and click into place.

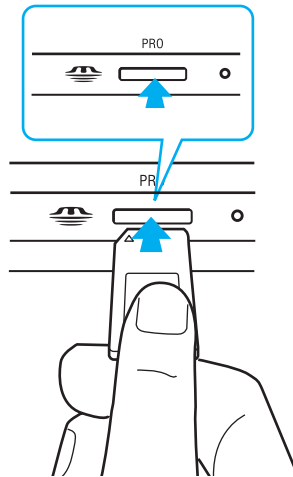

-  Be sure to insert the Memory Stick in the correct direction. If the Memory Stick is forced in the wrong way, it may become damaged. Insert only Memory Stick media into the Memory Stick slot. Attempting to insert other objects into the slot may damage the LCD projection TV. Before inserting a Memory Stick Duo into the Memory Stick slot, you must first insert the Memory Stick Duo into an adaptor (optional).

To remove a Memory Stick

- 1 Check that the Memory Stick indicator is off. (When the light is on, this indicates that the LCD projection TV is reading data from the Memory Stick.)

(Continued)

- 2 Push the Memory Stick gently into the slot, and then release it. The Memory Stick media is ejected.

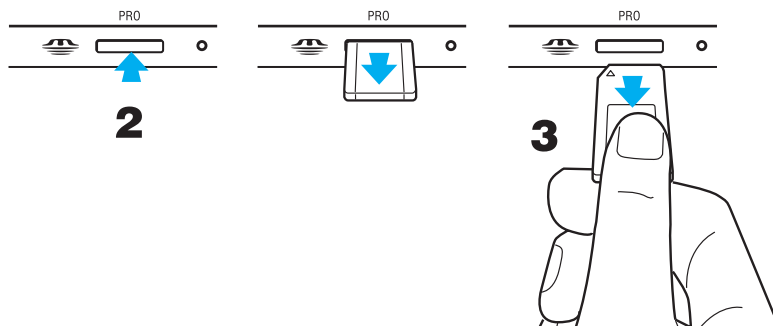

- 3 Pull the Memory Stick completely out of the slot.

 When removing the Memory Stick, do not attempt to just pull it from its slot.

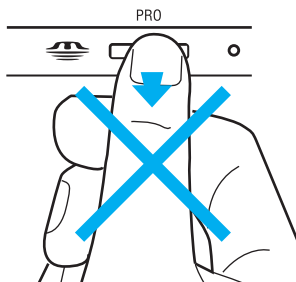

 To protect small children from injury from Memory Stick Media, remove all Memory Stick media from the LCD projection TV's Memory Stick slot and store it in a safe location when it is not in use.

Displaying the Memory Stick Home (Memory Stick Index)

Turn on the your LCD projection TV and insert a Memory Stick that contains the photo or movie files you want to view. For details on inserting a Memory Stick, see “To insert a Memory Stick” on page 57.

The Memory Stick Home appears, which displays thumbnails of still image and movie files stored on the Memory Stick.

When MEMORY STICK  on the remote control is pressed, the Memory Stick Home also appears.

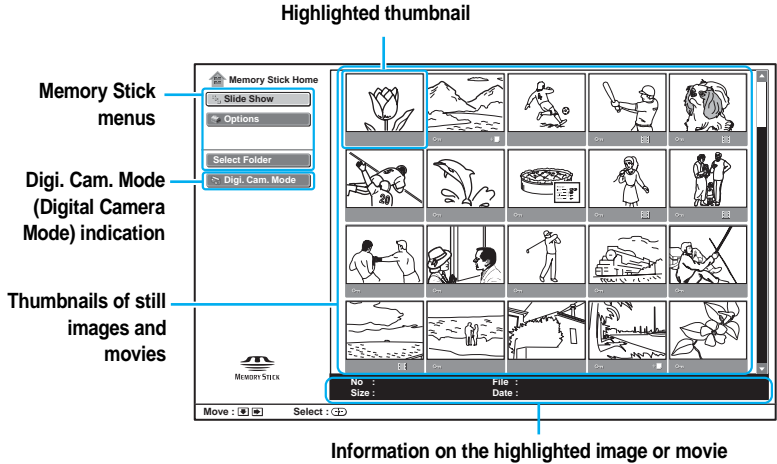

About the Icons on the Thumbnail Images

	(Movie)	Indicates the thumbnail is a movie (MPEG1) file.
	(Protect)	Indicates the thumbnail is protected. Protected files cannot be changed or deleted. For details, see “Using the Index Menu” on page 60.
	(Relative file)	Indicates another file named the same in the last four digits exists in the Memory Stick.

About the Digi. Cam. Mode (Digital Camera Mode)

Digi. Cam. Mode displays all JPEG and MPEG1 files recorded with the DCF compliant digital cameras. When you set the Digi. Cam. Mode to Off, the data of selected files or all files with the extension .jpg or .mpg can be displayed. The Memory Stick viewer of this projection TV sets Digi. Cam. Mode to On at the factory. When Digi. Cam. Mode is set to On, the maximum 2000 pieces of still images and/or movies can be displayed. When you want to display more than 2000 pieces of still images and/or movies, set Digi. Cam. Mode to Off. To set Digi. Cam. Mode to Off, see “Select Folder Menu Options” on page 66.

About caution displays

	This image data is the JPEG or MPEG1 format that is not-compatible.
	There is the thumbnail but it is not DCF-compatible.
	There is the image data but the thumbnail is broken.
	The image data is broken.

Using the Memory Stick Home

To Do This ...	Do This ...
Select the thumbnails	Press → .
Move the highlight to an image or movie thumbnail	Press ↑ ↓ ← → .
Display the previous or next page of thumbnails	<ol style="list-style-type: none"> 1 Select a file in the bottom row. 2 Press ↓. To go back to the previous page, press ↑. or 1 Select a file in the right-most column. 2 Press → to select a slider. 3 Press ↓. To go back to the previous page, press ↑.
Display the Index menu of the highlighted image or movie file to access additional options	Press ⊕ . For details on each Index menu, see “Using the Index Menu” on page 60.
Move the highlight to the Memory Stick Home menus to access additional options	<ol style="list-style-type: none"> 1 Press ↑ or ↓ to select Slideshow, Options or Select Folder. 2 Press ⊕. For details on these options, see “Memory Stick Home Menu Options” on page 65.
Exit Memory Stick Viewer	Press MEMORY STICK  on the remote control.

Using the Index Menu

When you select a still image or movie from the Memory Stick Home (see page 58), the Index menu appears with the following options. Press **↑** or **↓** to select the desired option.



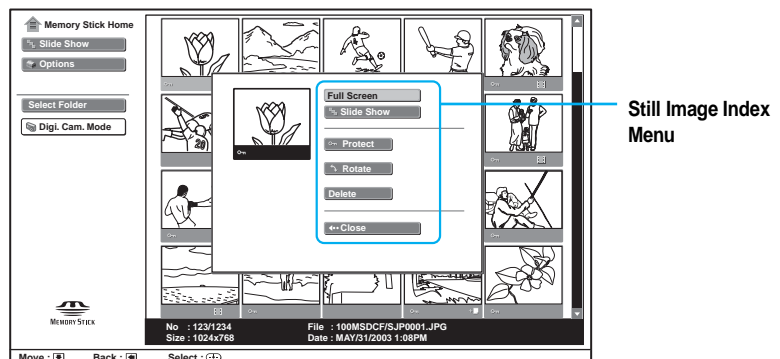

Still Image Index Menu

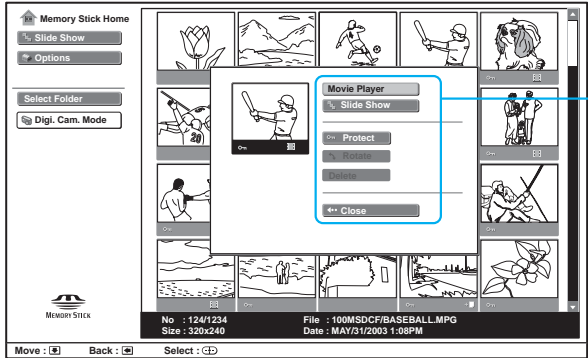

Movie Index Menu



Movie Index Menu

Option	Description	
Full Screen (Still image index menu only)	Displays the highlighted image file full screen. For details, see “Viewing Still Images” on page 62.	
Movie Player (Movie index menu only)	Display the Movie Player. For details, see “Playing Movies” on page 63.	
Slide Show	Starts the slide show from the highlighted image or movie.	
Protect	Allows you to protect the JPEG or MPEG1 file from any changes. Files that are protected are indicated by the  icon.	
	On	Protects the highlighted file.
	Off	Unlock the protect of the highlighted file.
Rotate	Allows you to rotate a still image in 90 degree increments clockwise or counterclockwise. Select  (clockwise) or  (counterclockwise). You cannot rotate a still image that has been protected (or if the Memory Stick is locked). This option is not available for a movie file.	
Delete	Deletes the JPEG or MPEG1 file from the Memory Stick. You cannot delete a file that has been protected (or if the Memory Stick is locked).	
	Selected	Deletes the highlighted file.
	After you select the option, the dialog appears. Select YES.	
Close	Displays the Memory Stick Home. Pressing  also returns to the Memory Stick Home.	

Viewing Still Images

When you select Full Screen from the Still image index menu and press **(+)**, it displays as shown below.

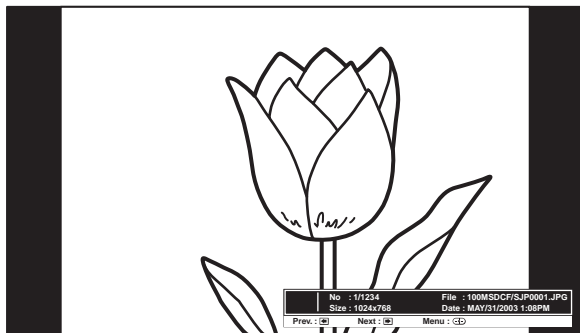

To Do This ...

Display the next or previous file on the Memory Stick

Access additional options

Exit Memory Stick Viewer

Do This ...

Press **→** to go to the next file, or **←** to go to the previous file.

Press **(+)**. For details, see “Image Setup Menu Options” on page 62.

Press **MEMORY STICK**  on the remote control.

Image Setup Menu Options

To access the Image setup menu

- 1 Press **↑** or **↓** to select the menu option.
- 2 Press **(+)**
- 3 Press **↑** or **↓** to select the desired option.

Image setup menu

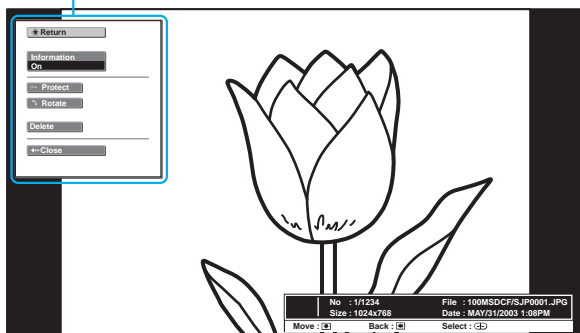

<i>Option</i>	<i>Description</i>
Return	Displays the Memory Stick Home.
Information	Allows you to turn on or off the display of file information. Select On or Off.
Protect	Allows you to protect this file from any changes. Selecting Off unlocks the protect.
Rotate	Allows you to rotate a still image in 90 degree increments clockwise or counterclockwise. If the file has been protected (or if the Memory Stick is locked), it cannot be rotated. Select ⌂ (clockwise) or ⌂ (counterclockwise).
Delete	Deletes the displayed file from the Memory Stick. Select Selected Items and press + . When the dialog appears, select YES. If the file has been protected (or if the Memory Stick is locked), it cannot be deleted.

Playing Movies

When you select Movie Player from the Movie index menu, it displays as shown below.

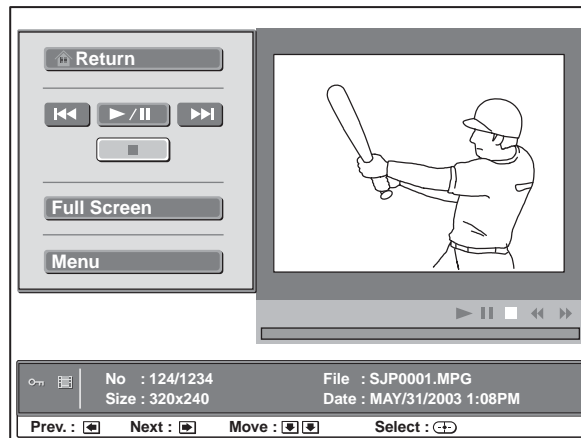

To Do This ...

Play (or pause) the movie.

Do This ...

1 Press **↑** or **↓** to select **▶/⏸**.

2 Press **+**.

Display the previous file on the Memory Stick

Press **←** during movie stop mode.

During playback or pause mode the control changes to **⏮** (Rewind).

(Continued)

To Do This ...	Do This ...
Display the next file on the Memory Stick	Press → during movie stop mode. During playback or pause mode the control changes to ▶▶ (Fast-forward).
Stop playback.	Press ↑ or ↓ to select ■ and press (+) .
Display the movie full screen	Press ↑ or ↓ to select Full Screen and press (+) . To display the Movie Player window, press (+) .
Display the Movie setup menu to access additional options	1 Press ↑ or ↓ to select Menu. 2 Press (+) . For details, see “Movie Setup Menu Options”.
Displays the Memory Stick Home.	1 Press ↑ or ↓ to select Return. 2 Press (+) .

 When displaying a large file, it will take longer time.

 The rewind and fast-forward may not work due to the movie file.

Movie Setup Menu Options

To access the Movie setup menu

- 1 Press **↑** or **↓** to select the menu option.
- 2 Press **(+)**
- 3 Press **↑** or **↓** to select the desired option.

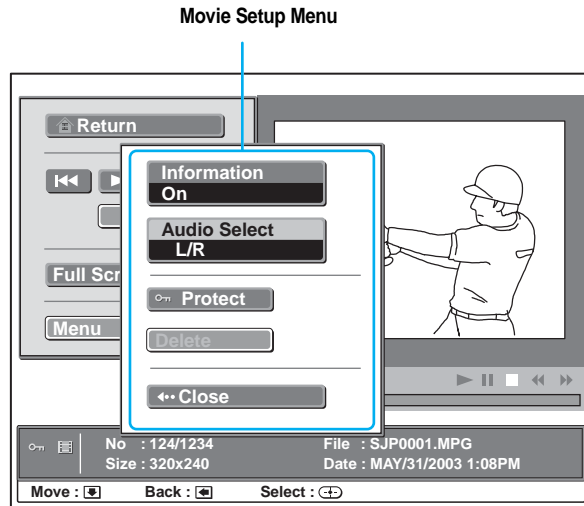

<i>Option</i>	<i>Description</i>
Information	Allows you to turn on or off the display of file information. Select On or Off .
Audio Select	Switches the sound to be heard. Select L (left sound), R (right sound) or L/R (left and right sounds) to hear the respective sound(s). The setting affects movie files.
Protect	Allows you to protect the file from any changes. Select On to protect. Select Off to unlock the protect.
Delete	Deletes the displayed file from the Memory Stick. Select Selected Items and press (+) . When the dialog appears, select YES . If the file has been protected (or if the Memory Stick is locked), it cannot be deleted.

Memory Stick Home Menu Options

The Memory Stick Home lets you select the Slide Show, Options and Select Folder menus that include additional options for each menu.

To access the Memory Stick Home menu

- 1 Press **↑** or **↓** to select Slide Show, Options or Select Folder.
- 2 Press **(+)**. The setup menu appears.
- 3 Press **↑** or **↓** to select the desired option and press **(+)**.

Slide Show Menu Options

The Slide Show menu includes the following menu options.

<i>Option</i>	<i>Description</i>
Start	Starts the slide show. Slide show plays all still and movie files. To stop the slide show, press (+) .
Advance	Auto Advances slides automatically. Slide show repeats after all files are displayed. Press (+) to stop the slide show.
	Manual Advances slides manually. Press → or ← on the remote control to go to the next or previous still or movie image file. Select ▶/■ to play movie files in the Movie Player window.
Interval	Allows you to specify a timed slide advance after a selected time interval. Select from 5 sec , 10 sec , 30 sec , 1 min and 5 min .
Close	Displays the Memory Stick Home.

Options Menu Options

The Options Menu includes the following options.

Option	Description
File	The File option is available when Digi. Cam. Mode is set to Off. For details, see “Using Select Folder Menu” on page 67.
Sort	Allows you to change the order in which the Memory Stick files are displayed. Select from Name Order \downarrow^A_Z (in alphabetical order by filename), Name Order \downarrow^Z_A (in reverse alphabetical order by filename), Date Order \downarrow^1_9 (in chronological order by recording or modification date) and Date Order \downarrow^9_1 (in reverse chronological order by recording or modification date).  The Sort function works only when fewer than 2000 files are saved.
Filter	Allows you to selectively display specific file types within the selected folder. Select from Show Stills (only still image files), Show Movies (only movie files), and Off (all readable files).
Memory Stick	Displays the current status of the Memory Stick, including Memory Stick type, total capacity, used capacity, and free capacity.

Select Folder Menu Options

The Select Folder Menu includes the following options.

Option	Description
Digi. Cam. Mode	On Off
	Displays only JPEG and MPEG1 files defined by the DCF rules and JPEG and MPEG1 files recorded on a Sony digital still camera or digital video camera.
	Displays all folders within the directories. JPEG and MPEG1 files in those directories are recognized even if they do not conform to the DCF file naming rules.

Using Select Folder Menu

Allows you to select different folders to view in the Memory Stick Viewer when you set Digi. Cam. Mode to Off.

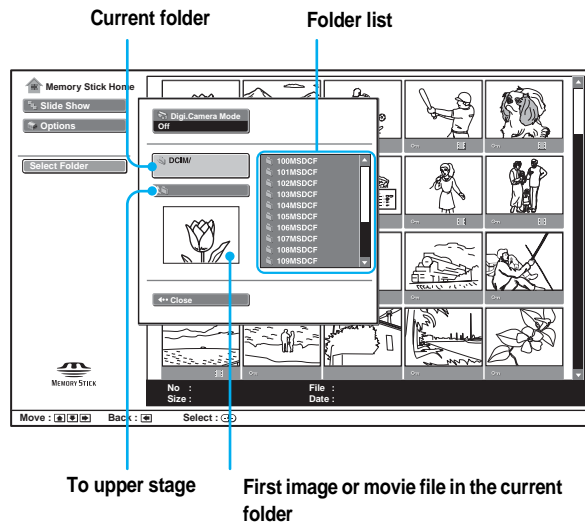

- 1 Select Off in Digi. Cam. Mode.
 - 2 Press \rightarrow to select the folder list.
 - 3 Press \uparrow or \downarrow to select the folder which includes the file you want, and press $\left(\oplus\right)$.
-  To select the hidden folders, press \rightarrow to select the slider and press \uparrow or \downarrow .

Using the Menus

Overview

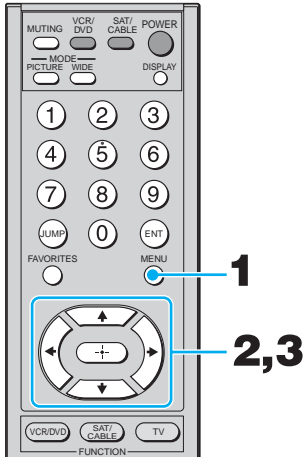

Opening and choosing a menu

- 1 Press MENU to display the menu screen.
- 2 Press ◀ or ▶ to highlight the desired menu icon and press (+) to select it.
- 3 Use the arrow button to scroll through the features.
- 4 See the specific menu page for instructions on moving through the menu.







To end a menu session

- Press MENU again.

To end one menu session and move to another

- Press ▲ to return to the menu icons.
Press ◀ or ▶ to choose the next menu icon and press (+) to select it.





The menu gives you access to the following features:

Menu Icon	Description	Page
	Allows you to make adjustments to your picture settings. It also allows you to customize the Picture Mode based on the type of program you are viewing.	69
	Offers enhanced audio options such as listening to second audio programming (SAP), or customizing the Effect of the sound on your LCD projection TV.	72
	Allows you to set the wide screen mode, adjust the vertical center in wide mode, and set the 4:3 Default mode.	74
	Allows you to set up a Favorite Channel list, run the Auto Program function, and more.	76
	Lets you control the viewing of programs based on their ratings.	78
	Provides several options for setting up your channels, labeling your Video inputs, and selecting the language of the on-screen menus.	82



Using the Video Menu

To select the Video Menu

- 1 Press MENU.
- 2 Press ◀ or ▶ to highlight the Video icon  and press .
- 3 Use the arrow button to scroll through the features.
- 4 Press  to select a feature. That feature's adjustment appears.
- 5 Use the arrow button to make the desired adjustments.
- 6 Press  to select/set.
- 7 Press MENU to exit the menu screen.

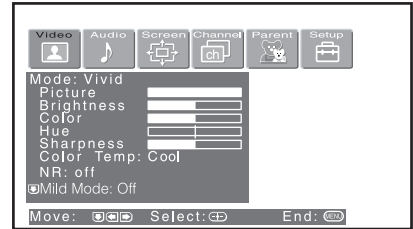



To restore the factory default settings for Picture, Brightness, Color, Hue, Sharpness and Color Temp

- ❑ Press RESET on the remote control when in the Video menu.





Selecting Video Options

The Video menu includes the following options.

Option	Description
Mode	Vivid Select for enhanced picture contrast and sharpness.
Customized picture viewing	Standard Recommended for Normal viewing conditions.
	Pro Select to display a picture with minimum enhancements.
<p> You can alter the Video menu settings (Picture, Brightness, Color, etc.) for each Mode.</p> <p> We recommend selecting Standard for normal home use.</p> <p> To quickly and easily change from one Video Mode to another, use PICTURE MODE on the remote control.</p>	
Picture	Adjust to increase picture contrast and deepen the color or decrease picture contrast and soften the color.
Brightness	Adjust to brighten or darken the picture.
Color	Adjust to increase or decrease color intensity.
Hue	Adjust to increase or decrease the green tones.
Sharpness	Adjust to sharpen or soften the picture.

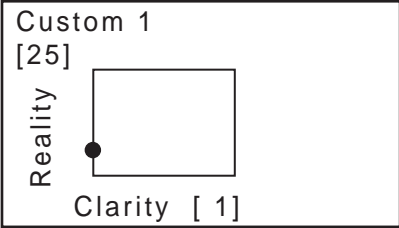
(Continued)

<i>Option</i>	<i>Description</i>		
Color Temp <i>White intensity adjustment</i>	Choose from three color temperatures:		
	Cool	Select to give the white colors a blue tint.	
	Neutral	Select to give the white colors a neutral tint.	
	Warm	Select to give the white colors a red tint.	
NR <i>Noise Reduction</i>	Select to reduce the noise level of connected equipment. It is also effective on the signal from the VHF/UHF jack. Select from High, Medium, Low and Off.		
Mild Mode	On	Select for a natural, soft picture.	
	Off	Select to turn off the Mild Mode.	
	✎ Mild Mode is unavailable when the Mode is set to vivid.		
Advanced Video	Program	DRC Mode	
		Creates a high-resolution picture with 4x density, for high quality sources (i.e., DVD player, satellite receiver).	
		High Density	Recommended for moving pictures.
		Progressive	Recommended for still images and text.
	CineMotion	Provides an optimized display by automatically detecting film content and applying a reverse 3/2 pulldown process. Moving pictures will appear clearer and more natural-looking.	

Option	Description
Advanced Video (Continued)	<p>Palette</p> <p>Allows you to customize the level of detail (Reality) and smoothness (Clarity) for up to three input sources. For example, you can create one Custom setting to optimize your cable input's picture, and create another to optimize your DVD player's picture. You can switch among the three Custom settings.</p>
	<p>1 Press the arrow button to highlight Custom 1, Custom 2, or Custom 3 and then press .</p> <p>The DRC palette appears.</p>
	
	<p>2 Press the arrow button to adjust the position of the marker (●). As you move the ● higher along the Reality axis, the picture becomes more detailed. As you move the ● to the right along the Clarity axis, the picture becomes smoother.</p>
	<p>3 To save the setting, press .</p> <p>To return the Custom options to the default factory settings, press the RESET button.</p>
	<p> Advanced Video is unavailable when you have selected Mild picture mode, or you are watching 1080i, 720p and 480p sources with Video 5 to 7 inputs.</p>
<p>BN Smoother <i>Block Noise Smoother</i></p>	<p>Select to reduce noise caused by video encoding and decoding process. It is especially effective for watching a DVD or HDTV picture. Select from High, Medium, Low and Off.</p>
	<p> An image may not be corrected due to the connected equipment.</p>



Using the Audio Menu

To select the Audio Menu

- 1 Press MENU.
- 2 Press **←** or **→** to highlight the Audio icon  and press **⏏**.
- 3 Use the arrow button to scroll through the options.
- 4 Press **⏏** to select an option. That option's settings appear.
- 5 Use the arrow button to scroll through the settings.
- 6 Press **⏏** to select the desired setting.
- 7 Press MENU to exit the menu screen.

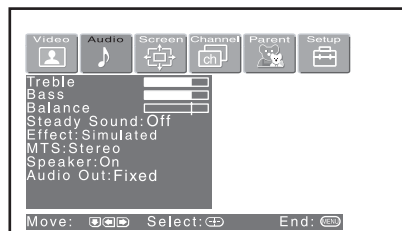

To restore the factory default settings for Treble, Bass and Balance

- Press RESET on the remote control when in the Audio menu.

Selecting Audio Options

The Audio menu includes the following options:

Option	Description
Treble	Adjust to increase or decrease higher-pitched sounds.
Bass	Adjust to increase or decrease lower-pitched sounds.
Balance	Adjust to emphasize left or right speaker balance.
Steady Sound	Auto Select to stabilize the volume.
	Off Select to turn off Steady Sound.
Effect	TruSurround Select for surround sound (for stereo programs only).
	Simulated Adds a surround-like effect to mono programs.
	Off Normal stereo or mono reception.
MTS <i>Enjoy stereo, bilingual and mono programs</i>	Stereo Select for stereo reception when viewing a program broadcast in stereo.
	Auto SAP Select to automatically switch the LCD projection TV to second audio programs when a signal is received. (If no SAP signal is present, the LCD projection TV remains in Stereo mode.)
	Mono Select for mono reception. (Use to reduce noise during weak stereo broadcasts.)

Option	Description	
Speaker	On	Select to turn on the LCD projection TV speakers.
	Off	Select to turn off the LCD projection TV speakers and listen to the LCD projection TV's sound only through your external audio system speakers.
Audio Out <i>Easy control of volume adjustments</i>	Variable	The LCD projection TV's speakers are turned off, but the volume output from your audio system can still be controlled by the LCD projection TV's remote control.
	Fixed	The LCD projection TV's speakers are turned off and the volume, bass and treble output of the LCD projection TV is fixed. Use your audio receiver's volume control to adjust the volume through your audio system.



Using the Screen Menu

To select the Screen menu

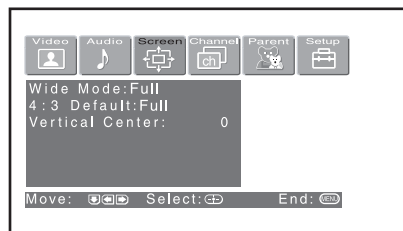

- 1 Press MENU.
- 2 Press **←** or **→** to highlight the Screen icon  and press **+**.
- 3 Use the arrow button to scroll through the features.
- 4 Press **+** to select a feature. That feature's options appear.
- 5 Use the arrow button to scroll through the options.
- 6 Press **+** to select the desired option.
- 7 Press MENU to exit the menu screen.











Selecting Screen Options

The Screen menu includes the following options:

-  To change from one Wide Mode to another, use WIDE MODE on the remote control.





Option	Description	
Wide Mode	Wide Zoom	
<i>Select a Screen Mode to use for 4:3 sources.</i>	Select to enlarge the 4:3 picture, to fill the 16:9 screen, keeping the original image as much as possible.	
	Normal	Select to return the 4:3 picture to normal mode.
	Full	Select to enlarge the 4:3 picture horizontally only, to fill the wide screen.
	Zoom	Select to enlarge the 4:3 picture horizontally and vertically to an equal aspect ratio that fills the wide screen.
	Wide Mode is unavailable while in Twin View (page 50) or Freeze (page 53).	
	Wide mode is unavailable when you are watching 720p and 1080i sources, and when viewing photos from your Memory Stick media.	

Option	Description
4:3 Default <i>Select the default Screen Mode to use for 4:3 sources.</i>	Wide Zoom Select to enlarge the 4:3 picture, to fill the 16:9 screen, keeping the original image as much as possible.
	Normal Select to return the 4:3 picture to normal mode.
	Full Select to enlarge the 4:3 picture horizontally only, to fill the wide screen.
	Zoom Select to enlarge the 4:3 picture horizontally and vertically to an equal aspect ratio that fills the wide screen.
	Off Select to continue using the current Screen Mode setting when the channel or input is changed.
	 The 4:3 Default functions only when the LCD projection TV receives 480i and 480p signals.  If 4:3 Default is set to anything but Off, the Wide Mode setting changes only for the current channel. When you change channels (or inputs), Wide Mode is automatically replaced with the 4:3 Default setting. To retain the current Wide Mode setting as channels and inputs are changed, set 4:3 Default to Off.
Vertical Center	Adjust Allows you to move the position of the picture up and down in the window. (Available only in Wide Zoom and Zoom modes.) Press  or  and press  to choose a position between +25 and -25 (Zoom mode), and +10 and -10 (Wide Zoom mode).
Vertical Size	Adjust Allows you to adjust the vertical size of the picture. (Available only in Wide Zoom and Zoom modes.) Press  or  and press  to choose a correction between +7 and -7.



Using the Channel Menu

To select the Channel Menu



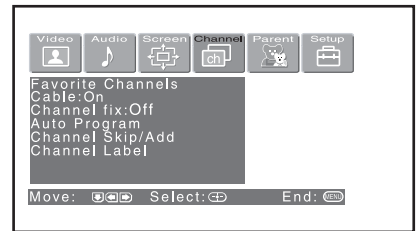











- 1 Press MENU.
- 2 Press ◀ or ▶ to highlight the Channel icon  and press .
- 3 Use the arrow button to scroll through the features.
- 4 Press  to select a feature. That feature's options appear.
- 5 Use the arrow button to scroll through the options.
- 6 Press  to select the desired option.
- 7 Press MENU to exit the menu screen.



Selecting Channel Options

The Channel menu includes the following options:

Option	Description
Favorite Channels	Let you set up a list of your favorite channels. For details, see “Using Favorite Channels” on page 49.
Cable	<p>On Select if you are receiving cable channels with a CATV cable.</p> <p>Off Select if you are using an antenna.</p> <p> You should run Auto Program after changing the Cable setting.</p>
Channel Fix	<p>2-6 “Fix” your LCD projection TV’s channel setting to 3 or 4 and use the cable box, VCR or satellite receiver to change channels. Select one of these settings if you have connected the device to the VHF/UHF jack.</p> <p>AUX 2-6 Same as 2-6, except you select one of these settings if you have connected the device to the AUX jack (see page 23).</p> <p>Video 1 Use when connecting a cable box. TV output should be connected through the cable box.</p>
Auto Program	Automatically programs the LCD projection TV for all receivable channels.



<i>Option</i>	<i>Description</i>
Channel Skip/Add	<p data-bbox="623 187 991 213">Removes and adds viewable channels.</p> <ol style="list-style-type: none"> <li data-bbox="623 227 1217 288">1 Use the arrow button to scroll through the channels until you find the channel you want to skip/add. <li data-bbox="623 302 897 328">2 Press  to select it. <li data-bbox="623 348 1157 374">3 Press  or  to toggle between “Add” and “Skip.” <li data-bbox="623 395 878 421">4 Press  to select. <p data-bbox="623 442 1233 499"> Channels that you set to be skipped can be accessed only with the 0-9 buttons.</p>
Channel Label	<p data-bbox="623 513 1184 565">Allows you to assign labels (such as station call letters) to channel numbers. You can label up to 40 channels.</p> <ol style="list-style-type: none"> <li data-bbox="623 579 1188 640">1 Press the arrow button to highlight Channel and press . <li data-bbox="623 654 1237 748">2 Press  or  to scroll through the channel numbers (1-125). Then press  to select the channel number that you want to assign a label. <li data-bbox="623 762 1233 788">3 Press the arrow button to highlight Label and press . <li data-bbox="623 808 1237 885">4 Press  or  to scroll through the label characters (A-Z, 0-9, etc.). Then press  to select the highlighted character. <li data-bbox="623 906 1099 932">5 Repeat to add up to 5 characters to the label. <li data-bbox="623 953 1166 979">6 To assign labels to more channels, repeat steps 1-4. <li data-bbox="623 999 1233 1058">7 Press  to return to the Channel Menu, or press MENU to exit the Menus. <p data-bbox="623 1072 1180 1124"> Channel Label is not available (grayed out) when watching the AUX and VIDEO inputs.</p>





Using the Parent Menu

The Parent Menu allows you to set up the TV to block programs according to their content and rating levels.

To select the Parent Menu

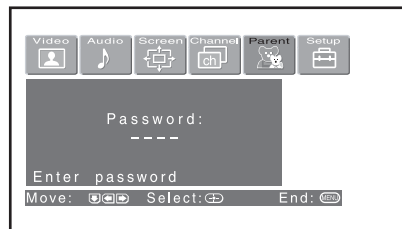
- 1 Press MENU.
- 2 Press ◀ or ▶ to highlight the Parent icon  and press .
- 3 Use the 0-9 buttons on the remote control to enter a four-digit password.
- 4 If this is the first time you are creating this password, confirm the password by entering it again. (The Parent Menu options appear.)
- 5 Press ▲ ▼ ◀ ▶ to change settings. Press  to select the changed setting.
- 6 Press MENU to exit the Menu.





 You need your password for any future access into the Parent Menu. If you lose your password, see “Lost password” on page 97.

Selecting Parent Options

The Parent Menu includes the following options:

Option	Description
Parental Lock <i>Turn ratings on/off and select a rating system</i>	Off Parental lock is off. No programs are blocked from viewing.
	Child Maximum ratings permitted are: US: TV-Y, TV-G, G Canada: C, G, TV-Y
	Youth Maximum ratings permitted are: US: TV-PG, PG Canada: C8+, PG, 8 ans+, TV-PG
	Y. Adult Maximum ratings permitted are: US: TV-14, PG-13 Canada: 14+, 13 ans+, TV-14
	Custom Select to set ratings manually. US: See page 80 for details. Canada: See page 81 for details.

Option	Description
	 If you are not familiar with the Parental Guideline rating system, you should select Child, Youth, or Young Adult to help simplify the rating selection. To set more restrictive ratings, select Custom.
	 For descriptions of Child, Youth, and Young Adult ratings, see page 80.
Change Password	For changing your password.
Select Country	U.S.A. Select to use USA ratings (see page 80). Canada Select to use Canadian ratings (see page 81).

To deactivate the Parental Control feature

- Set Parental Lock to OFF when in the Parent menu.

To change the password

- 1 Select Change Password option when in the Parent menu using the arrow button, and press .
- 2 Enter a new four-digit password using the 0-9 buttons.
- 3 Confirm the new password by entering it again.
- 4 Press MENU to exit the menu screen.

Viewing Blocked Programs

You can view a blocked program by entering the password.

- 1 Press ENTER when tuned to a blocked program.
- 2 Enter your password using the 0-9 buttons.
Parental Control will be canceled temporarily until you turn your LCD projection TV off.

Selecting Custom Rating Options

US custom rating options

If you selected U.S.A. as the country of residence on page 79, the Custom Rating Menu includes the following options. (If you selected Canada, see page 81.)

 To ensure maximum blocking capability, the age-based ratings should be blocked.

Option	Description	
Movie Rating	G All children and General Audience.	
	PG Parental Guidance suggested.	
	PG-13 Parental Guidance for children under 13.	
	R Restricted viewing, parental guidance is suggested for children under 17.	
	NC-17 and X No one 17 and under allowed.	
TV Rating	Age-Based Options	
<i>Block programs by their rating, content or both</i>	TV-Y All children.	
	TV-Y7 Directed to older children.	
	TV-G General Audience.	
	TV-PG Parental Guidance suggested.	
	TV-14 Parents Strongly cautioned.	
	TV-MA Mature Audience only.	
	Content-Based Options	
	FV Fantasy Violence.	
	D Suggestive Dialogue.	
	L Strong Language.	
S Sexual situations.		
V Violence.		
Unrated	Block Blocks all programs and movies that are broadcast without a rating.	
	Allow Allows programs and movies that are broadcast without a rating.	
	 If you select "Block," please be aware that the following programs may be blocked: emergency broadcasts, political programs, sports, news, public service announcements, religious programs and weather.	

 The content ratings will increase depending on the level of the age-based rating. For example, a program with a TV-PG V (Violence) rating may contain moderate violence, while a TV-14 V (Violence) rating may contain more intense violence.

Canadian custom rating options





If you selected Canada as the country of residence on page 79, the Custom Rating Menu includes the following options. (If you selected U.S.A., see page 80.)

<i>Option</i>	<i>Description</i>	
English Rating	C	All children.
	C8+	Children 8 years and older.
	G	General programming.
	PG	Parental Guidance.
	14+	Viewers 14 and older.
	18+	Adult programming.
French Rating	G	General programming.
	8 ans+	Not recommended for young children.
	13 ans+	Not recommended for ages under 13.
	16 ans+	Not recommended for ages under 16.
	18 ans+	Programming restricted to adults.
USA Rating	See “TV Rating” on page 80 for details.	



Using the Setup Menu

To select the Setup Menu

- 1 Press MENU.
- 2 Press ← or → to highlight the Setup icon  and press .
- 3 Use the arrow button to scroll through the features.
- 4 Press  to select a feature. That feature's options appear.
- 5 Use the arrow button to scroll through the options.
- 6 Press  to select the desired option.
- 7 Press MENU to exit the menu screen.

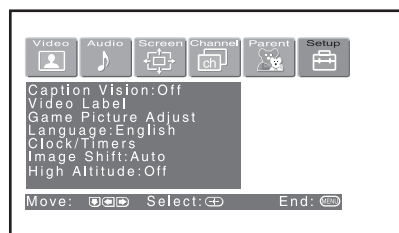

Selecting Setup Options

The Setup menu includes the following options:

Option	Description
Caption Vision	Allows you to select from three closed caption modes (for programs that are broadcast with closed captioning).
Off	Turns off Caption Vision.
CC1, CC2, CC3, CC4	Displays a printed version of the dialog or sound effects of a program. (Should be set to CC1 for most programs.)
Text1, Text2, Text3, Text4	Displays network/station information presented using either half or the whole screen (if available). For closed captioning, set to CC1.
Info	Displays the program name and the time remaining in the program (if the broadcaster offers this service). Displays when the channel is changed or the DISPLAY button is pressed.

<i>Option</i>	<i>Description</i>
Video Label	<p>Allows you to label the audio/video components you connected to the LCD projection TV so you can identify them when using TV/VIDEO. When in the Setup menu's Video Label feature, press ▲ or ▼ to highlight an input to label, then press (+) to select it. Use the arrow button to scroll through the labels. Press (+) to select the component you connected to each of the input jacks on the back of your LCD projection TV. Select "Skip" if you do not have a component connected to a particular set of input jacks.</p>
Video 1/2/3/4	VHS, DVD, Receiver, Satellite, Cable Box, 8mm, DTV, Game, LD, Web, Beta, Skip
Video 5/6/7	DVD, Satellite, Cable Box, DTV, HD, Game, Skip
	<p>If you select "Skip," your LCD projection TV skips this connection when you press TV/VIDEO.</p>
	<p> When you select "Receiver" on Video Label, your LCD projection TV's input is fixed (for Video 1 only).</p>
Game Picture Adjust	<p>Allows you to move the position of the picture left and right in the window. (Available for the picture of connected equipment.) Select while watching the picture to be adjusted. The TV stores the position in memory for each input.</p>
Language	<p>Select to display all on-screen menus in your language of choice: English, Español, Français.</p>

(Continued)

Option	Description
Clock/Timers	Lets you set the clock on your TV and allows you to program your TV for scheduled viewing using the Timers.
Sleep	Allows you to select the time in minutes (15, 30, 45, 60, or 90) that you want the TV to remain on before shutting off automatically.
Timer 1 Timer 2	You can use the Timers to program the TV to turn on and off and tune to a specific channel at two scheduled viewing times.
Timer 1 and Timer 2 are not available to be set until you set the Current Time.	
<p>1 Press ▲ or ▼ to highlight Timer 1 or Timer 2. To set the timer, press ▶.</p>	
<p>2 Press ▲ or ▼ to highlight one of the following options, then press ⊕.</p>	
Program	Select to set the Timer by day, time, duration, and channel.
Off	Select to turn off the Timer. (Your previous settings are saved.)
<p>3 If you selected Program in step 2, press ▲ and ▼ to set the day(s), hour, minute, duration, and channel number. Press ⊕ or press ▶ to confirm each setting and move to the next setting. Press ◀ to go back to the previous setting.</p>	
<p>4 Press MENU to exit the Menu. An LED on the front panel will light, indicating the timer has been set.</p>	
<p> To go directly to programming Timer 1 or 2, press ⊕ instead of pressing ▶.</p>	
Current Time	
<p>1 Press ⊕ to select Current Time.</p>	
<p>2 Press ▲ and ▼ to set the current time (day, hour, and minute). Press ⊕ (or press ▶) to confirm each setting and move to the next setting. Press ◀ to go back the previous setting.</p>	
<p>3 Press MENU to exit the Menu.</p>	

Option	Description
--------	-------------

Image Shift	Corrects the Image on your LCD projection TV.
	Before adjusting

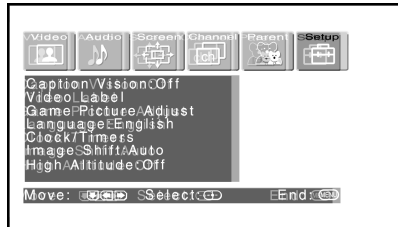

After adjusting

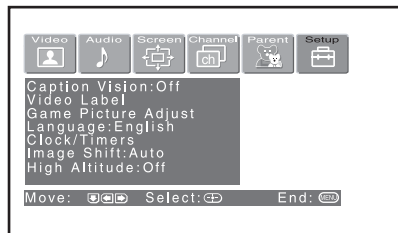

Auto: (Factory setting) Automatically corrects double images.

Level 1-4 (manual): Select the value with which double images are improved.

High Altitude	On	Set to use the unit at an altitude of 1,500 m (4921 ft.) or higher.
	Off	Set to use the unit at normal altitudes.

Other Information

Programming the Remote Control

If you have video equipment that you want to control with the LCD projection TV's remote control, use the following procedures to program the remote control.



 The equipment must have infrared (IR) remote capability in order to be used with the remote control.

From the “Manufacturer’s Codes” listed on page 87, select the three-digit code number for the manufacturer’s code for your component. If more than one code number is listed, start with the number listed first. Use the code number to complete the following procedure.

- 1 Press CODE SET.
- 2 Press the desired FUNCTION button.
- 3 Input the three-digit manufacture's code number.
- 4 Press ENT.

 When no code number is input for 30 seconds or invalid or incorrect numbers are input, the remote control is reset to the normal TV remote control mode.

Tips

-  If more than one code number is listed, try entering them one by one until you come to the correct code for your component.
-  If you enter a new code number, the code number you previously entered at that setting is erased.
-  In some rare cases, you may not be able to operate your component with the Sony remote control. In this case, use the component’s own remote control unit.

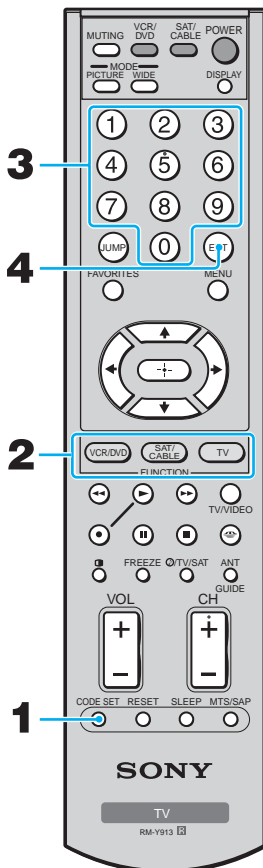

Other Information

Manufacturer's Codes

VCRs

<i>Manufacturer</i>	<i>Code</i>
Sony	301
Admiral (M. Ward)	327
Aiwa	338, 344
Audio Dynamic	314, 337
Broksonic	319, 317
Canon	309, 308
Citizen	332
Craig	302, 332
Criterion	315
Curtis Mathes	304, 338, 309
Daewoo	341, 312, 309
DBX	314, 336, 337
Dimensia	304
Emerson	319, 320, 316, 317, 318, 341
Fisher	330, 335
Funai	338
General Electric	329, 304, 309
Go Video	322, 339, 340
Goldstar	332
Hitachi	306, 304, 305, 338
Instant Replay	309, 308
JC Penney	309, 305, 304, 330, 314, 336, 337
JVC	314, 336, 337, 345, 346, 347
Kenwood	314, 336, 332, 337
LXI (Sears)	332, 305, 330, 335, 338
Magnavox	308, 309, 310
Marantz	314, 336, 337
Marta	332
Memorex	309, 335
Minolta	305, 304
Mitsubishi/MGA	323, 324, 325, 326
Multitech	325, 338, 321

<i>Manufacturer</i>	<i>Code</i>
NEC	314, 336, 337
Olympic	309, 308
Optimus	327
Panasonic	308, 309, 306, 307
Pentax	305, 304
Philco	308, 309
Philips	308, 309, 310
Pioneer	308
Quasar	308, 309, 306
RCA/PROSCAN	304, 305, 308, 309, 311, 312, 313, 310, 329
Realistic	309, 330, 328, 335, 324, 338
Sansui	314
Samsung	322, 313, 321
Sanyo	330, 335
Scott	312, 313, 321, 335, 323, 324, 325, 326
Sharp	327, 328
Shintom	315
Signature 2000 (M. Ward)	338, 327
SV2000	338
Sylvania	308, 309, 338, 310
Symphonic	338
Tashiro	332
Tatung	314, 336, 337
Teac	314, 336, 338, 337
Technics	309, 308
Toshiba	312, 311
Wards	327, 328, 335, 331, 332
Yamaha	314, 330, 336, 337
Zenith	331

DVD Players

<i>Manufacturer</i>	<i>Code</i>
Apex	762

Sony	751
Panasonic	753
Pioneer	752
RCA	755
Toshiba	754

Cable Boxes

<i>Manufacturer</i>	<i>Code</i>
Hamlin/Regal	223, 224, 225, 226
Jerrold/G. I.	201, 202, 203, 204, 205, 206, 207, 208, 218, 222
Oak	227, 228, 229
Panasonic	219, 220, 221
Pioneer	214, 215
Scientific Atlanta	209, 210, 211
Sony	230
Tocom	216, 217
Zenith	212, 213

Satellite Receivers

<i>Manufacturer</i>	<i>Code</i>
Sony	801
General Electric	802
Hitachi	805
Hughes	804
Panasonic	803
RCA/ PROSCAN	802, 808
Toshiba	806, 807

Others

<i>Manufacturer</i>	<i>Code</i>
Sony (5.1ch AV Amp)	763
Sony (AV Receiver)	764

Operating Other Components with Your LCD Projection TV Remote Control

Operating a VCR

Press FUNCTION VCR/DVD.

To Do This ...	Press
Turn on/off	SAT/CABLE (POWER)
Change channels	CH +/-
Record	▶ and ● simultaneously
Play	▶
Stop	■
Fast forward	▶▶
Rewind the tape	◀◀
Pause	(press again to resume normal playback)
Search the picture forward or backward	▶▶ or ◀◀ during playback (release to resume normal playback)

Operating a DVD Player

Press FUNCTION VCR/DVD.

To Do This ...	Press
Turn on/off	SAT/CABLE (POWER)
Play	▶
Stop	■
Pause	(press again to resume normal playback)
Step through different tracks of an audio disc	▶▶ to step forward or ◀◀ to step backward
Step through different chapters of a video disc	CH+ to step forward or CH- to step backward

Operating a Cable Box

Press FUNCTION SAT/CABLE.

To Do This ...	Press
Turn on/off	SAT/CABLE (POWER)
Select Cable Box	SAT/CABLE (FUNCTION)
Select a channel	0-9 buttons, ENTER
Change channels	CH +/-
Back to previous channel	JUMP

Operating a Satellite Receiver

Press FUNCTION SAT/CABLE.

To Do This ...	Press
Turn on/off	SAT/CABLE (POWER)
Select Satellite Receiver	SAT/CABLE (FUNCTION)
Select a channel	0-9 buttons, ENTER
Change channels	CH +/-
Back to previous channel	JUMP
Display channel number	DISPLAY
Display DBS menu	MENU
Select item	

Notes on Using Memory Stick, Memory Stick PRO Media

Memory Stick, Memory Stick PRO Precautions

When using Memory Stick, Memory Stick PRO media, follow these precautions:

- ❑ To avoid permanent damage to still image data, do not turn off the TV or remove Memory Stick media from the insertion slot while data is being read (as indicated by the Memory Stick indicator light being on).
- ❑ Avoid touching the terminal of Memory Stick media or bringing it into contact with a metal object.
- ❑ Do not drop, bend, or submit Memory Stick media to external shock.
- ❑ Do not disassemble or modify Memory Stick media.
- ❑ Avoid getting liquid on Memory Stick media.
- ❑ Apply labels only within the designated label area.

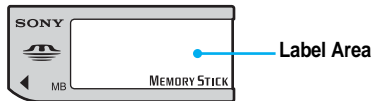

- ❑ To avoid permanent damage to still image data, do not use or store Memory Stick media in a location subject to:
 - ❑ High temperature (such as near a heater or inside a hot car)
 - ❑ High humidity
 - ❑ Direct sunlight
 - ❑ Corrosive substances
 - ❑ Magnetic fields
 - ❑ Excessive dust
 - ❑ Static electricity or electric noise
 - ❑ Electric surges
- ❑ Store and carry Memory Stick media in its original case to ensure protection of stored data.
- ❑ Save a backup of stored data.
- ❑ Memory Stick PRO of maximum 1GB-memory can be used for this unit.

Notes on Using Memory Stick Duo

Memory Stick Duo is a new, compact version of the standard-sized Memory Stick recording medium. You can use a Memory Stick Duo on your LCD projection TV by inserting a Memory Stick Duo into an adapter before inserting it into the TV.

- ❑ Be sure to attach a Memory Stick Duo to the adapter with the correct orientation.
- ❑ Be sure to insert the Memory Stick Duo adapter into the Memory Stick slot with the correct orientation. Otherwise, the LCD projection TV may be damaged.
- ❑ Do not insert the Memory Stick Duo adapter without the Memory Stick Duo attached. Doing so may result in malfunction of the LCD projection TV.

Contacting Sony

If, after reading these operating instructions, you have additional questions related to the use of your Sony television, please call our Customer Information Services Center at 1-800-222-SONY (7669) (US residents only) or (416) 499-SONY (7669) (Canadian residents only).

Troubleshooting

Twin View

Problem	Possible Remedies
I cannot get Twin View to work	<ul style="list-style-type: none">❑ If you are using a cable box to unscramble all channels (as shown on page 28), you cannot use the Twin View feature. This is because the cable box can unscramble only one channel at a time.❑ You can use Twin View to view a signal from a different source that is connected to the TV's A/V jacks (such as a VCR or DVD player) in the second window by pressing TV/VIDEO while in Twin View.❑ Sources connected to the AUX, HD/DVD IN 5 and 6, DVI-HDTV IN 7 inputs display in the left Twin View window, but not the right.
There is no Twin View window, or it is just static	<ul style="list-style-type: none">❑ Be sure the Twin View window is set to a video input or channel that has a signal airing.❑ You might be tuned to a video input with nothing connected to it. Try cycling through the video inputs by pressing TV/VIDEO.
Twin View cannot display anything but TV channels	<ul style="list-style-type: none">❑ Try cycling through the video inputs by pressing TV/VIDEO. Check that the Video Label option is not set to Skip. (See the Setup Menu on page 83.)
Twin View displays the same program in both windows	<ul style="list-style-type: none">❑ Both Twin View windows might be set to the same channel. Try changing channels in either window.

Remote Control

Problem	Possible Remedies
Remote control does not operate	<ul style="list-style-type: none"> <input type="checkbox"/> The batteries could be weak. Replace the batteries. <input type="checkbox"/> Check the orientation of the batteries. <input type="checkbox"/> Press FUNCTION (VCR/DVD, SAT/CABLE or TV) to select the equipment that you want to operate. <input type="checkbox"/> Make sure this unit's power cord is connected securely to the wall outlet. <input type="checkbox"/> Locate the unit at least 3-4 feet away from fluorescent lights.
Cannot change channels with the remote control	<ul style="list-style-type: none"> <input type="checkbox"/> If you are using the TV to change channels, first press FUNCTION TV button. <input type="checkbox"/> If you are using another device to change channels, be sure you have not inadvertently switched your TV from the channel 3 or 4 setting. Use the Channel Fix option to "fix" the channel based on the hookup you used (see page 76). <input type="checkbox"/> If you are using another device to change channels, be sure to press FUNCTION (VCR/DVD, SAT/CABLE or TV) for that device.
Remote control does not operate non-Sony video equipment	<ul style="list-style-type: none"> <input type="checkbox"/> If you replaced the batteries to the remote recently, the code numbers for the video equipment may need to be reset. <input type="checkbox"/> There may be more than one code for the equipment that you are attempting to operate. <input type="checkbox"/> There is a possibility that some non-Sony equipment cannot be operated by your Sony TV remote. You may need to use the equipment's original remote control.

Memory Stick

Problem	Possible Remedies
Image does not display	<ul style="list-style-type: none"> <input type="checkbox"/> Make sure the Memory Stick is inserted properly (see page 57). <input type="checkbox"/> Memory Stick functions are not available while using Twin View, Freeze or Favorite Channel functions. <input type="checkbox"/> Press the MEMORY STICK button (see page 45). <input type="checkbox"/> Make sure that the photo or movie files are contained in the Memory Stick. <input type="checkbox"/> Set Digi. Cam. Mode to Off and select the folder when the photo or movie image is processed by the computer.
"No Memory Stick" is displayed	<ul style="list-style-type: none"> <input type="checkbox"/> Make sure the Memory Stick is inserted properly (see page 57).
"Memory Stick error" is displayed	<ul style="list-style-type: none"> <input type="checkbox"/> The Memory Stick is not correct. Remove the Memory Stick and insert it again (see page 57). <input type="checkbox"/> The Memory Stick may be broken. Insert another Memory Stick.
"File error" is displayed	<ul style="list-style-type: none"> <input type="checkbox"/> A name of the selected file is not correct.
"Format error" is displayed	<ul style="list-style-type: none"> <input type="checkbox"/> The Memory Stick is not formatted correctly. Format correctly with other equipment such as a digital camera or insert another Memory Stick formatted correctly.
"Cannot play" is displayed	<ul style="list-style-type: none"> <input type="checkbox"/> Make sure that the photo or movie files to be played back are contained in the Memory Stick. <input type="checkbox"/> Set Digi. Cam. Mode to Off and select the folder.

(Continued)

Other Information

Problem	Possible Remedies
"Memory Stick type error" is displayed	<input type="checkbox"/> A Memory Stick not available for use with this LCD projection TV is inserted.
"No files that can be displayed" is displayed	<input type="checkbox"/> The photo or movie image to be played back is not contained when the Digi. Cam. Mode is set to On.
"No files in this folder that can be displayed" is displayed	<input type="checkbox"/> The photo or movie image is not contained in the selected folder when the Digi. Cam. Mode is set to Off.
"Memory Stick Locked" is displayed	<input type="checkbox"/> The Memory Stick is locked. Unlock the Memory Stick.
"No movie file" is displayed	<input type="checkbox"/> Show Movies is selected from Filter of the Option menu. However there is no movie file in the folder.
"No still file" is displayed	<input type="checkbox"/> Show Stills is selected from Filter of the Option menu. However there is no still file in the folder.
Cannot use Memory Stick Duo	<input type="checkbox"/> Check that the Memory Stick Duo and adaptor are inserted correctly.
Blank square appears instead of a thumbnail image	<input type="checkbox"/> This indicates that the image does not support a thumbnail view. Selecting the icon, however, displays the full-size image on the screen. It could also indicate that both the thumbnail and full-size images are corrupted or not supported.
Cannot rotate image, no thumbnail appears	<input type="checkbox"/> Be sure the LOCK switch on the Memory Stick is set to off. <input type="checkbox"/> If a blank square appears instead of the thumbnail image, this indicates that the image does not support a thumbnail view and cannot be rotated.
Cannot hear audio while using Memory Stick	<input type="checkbox"/> There is no audio available while using Memory Stick.
Image file name does not appear; instead, dashes (---) appear	<input type="checkbox"/> Dashes appear instead of the file name if the image was recorded using equipment that is not DCF-compliant. Dashes also appear if a DCF-compliant file was renamed.

Video

Problem	Possible Remedies
No picture (screen not lit), no sound	<input type="checkbox"/> If your LCD projection TV does not turn on, and a red light keeps flashing, your LCD projection TV may need service. Call your local Sony Service Center. <input type="checkbox"/> Make sure the power cord is plugged in. <input type="checkbox"/> Press POWER/STANDBY on the front of the LCD projection TV. <input type="checkbox"/> Check to see if the TV/VIDEO setting is correct: when watching TV, set to TV, and when watching connected equipment, set to VIDEO 1, 2, 3, 4, 5, 6 or 7. <input type="checkbox"/> The Parental Control feature is activated (See "Using the Parent Menu" on page 78.). <input type="checkbox"/> If your LCD projection TV's power is on, and LAMP (red) indication is flashing, the lamp for the light source burns out. Replace it with new Sony XL-2100U replacement lamp (see page 13). <input type="checkbox"/> Try another channel; it could be station trouble.

Problem	Possible Remedies
Dark, poor or no picture (screen lit), good sound	<ul style="list-style-type: none"> ❑ Adjust the Picture option in the Video Menu (see page 69). ❑ Adjust the Brightness option in the Video Menu (see page 69). ❑ Check the antenna/cable connections. <p>It is strongly recommended to connect the antenna using a 75-ohm coaxial cable to get optimum picture quality. A 300-ohm twin lead cable can be easily affected by radio noise and the like, resulting in signal deterioration. If you use a 300-ohm twin lead cable, keep it away as far as possible from the LCD projection TV. Do not use an indoor antenna because it is especially susceptible to radio noise (see page 25).</p>
No color	<ul style="list-style-type: none"> ❑ Adjust the Color option in the Video Menu (see page 69).
Only snow and noise appear on the screen	<ul style="list-style-type: none"> ❑ Check the antenna/cable connections. ❑ Check the Cable setting in the Channel menu (see “Cable” on page 76). ❑ Make sure the channel is broadcasting programs. ❑ Press ANT to change the input mode (see page 45).
Dotted lines or stripes	<ul style="list-style-type: none"> ❑ Adjust the antenna. ❑ Move the LCD projection TV away from noise sources such as cars, neon signs, or hair-dryers.
Double images	<ul style="list-style-type: none"> ❑ Use a highly directional outdoor antenna or a cable (when the problem is caused by reflections from nearby mountains or tall buildings). ❑ Set the Image Shift to an appropriate value. The default setting is Auto. If doubled images appear with Auto, select the best value from 1 to 4 (see page 85).
“Black box” on screen	<ul style="list-style-type: none"> ❑ You have selected a text option in the Setup Menu and no text is available. (see page 82) to reset Setup selections.) To turn off this feature, set the Caption Vision option to Off. If you were trying to select closed captioning, select CC1 instead of Text 1-4.
Black bands appear at the top and bottom of the screen	<ul style="list-style-type: none"> ❑ Some wide-screen programs are filmed in aspect ratios that are greater than 16:9 (this is especially common with theatrical releases). Your LCD projection TV will show these programs with black bands at the top and bottom of the screen. For more details, check the documentation that came with your DVD (or contact your program provider).
Certain programs on DVD or other digital sources display a loss of detail, especially during fast-motion or dark scenes	<ul style="list-style-type: none"> ❑ The compression used by certain digital broadcasts and DVDs may cause your TV’s screen to display less detail than usual, or cause artifacts (small blocks or dots, pixelations) to appear on your screen. This is due to your TV’s large screen and ability to show very fine detail, and is normal for certain digitally recorded programs. Adjust the reality/clarity in the Palette menu (see page 71) to optimize the picture while viewing these sources.
Some video sources do not appear when you press TV/VIDEO	<ul style="list-style-type: none"> ❑ Ensure that Video Label is not set to “Skip” (see “Video Label” on page 83).

(Continued)

Audio

<i>Problem</i>	<i>Possible Remedies</i>
Good picture, no sound	<ul style="list-style-type: none">❑ Press MUTING so that Muting disappears from the screen (see page 44).❑ Make sure the Speaker option is set to On in the Audio Menu (see page 73).
Audio noise	<ul style="list-style-type: none">❑ Communication problems may occur if the infrared communication equipment (e.g., infrared cordless headphones) is used near the TV. Please use headphones other than infrared cordless headphones. Also, if you use the infrared communication equipment other than infrared cordless headphones, move the infrared transceiver away from the TV until the noise is eliminated, or move the transmitter and receiver of the infrared communication equipment closer together.
Cannot gain enough volume when using a cable box	<ul style="list-style-type: none">❑ Increase the volume of the cable box using the cable box's remote control. Then press FUNCTION TV button and adjust the TV's volume.
Sound seems weak or insufficient	<ul style="list-style-type: none">❑ The TV's audio might be set to Auto SAP or Mono, when it might be better set to Stereo. In the Audio Menu (see page 72), set the MTS setting to Stereo. If already set to Stereo, switch to Mono (which may reduce background noise during weak stereo broadcasts).
Cannot raise the volume on external speakers	<ul style="list-style-type: none">❑ If the Speaker option is set to Off and the Audio Out option is set to Fixed (in order to output the sound to your audio system) use your audio receiver to adjust the sound (see page 73). Or, to use the TV remote control, set the Audio Out option to Variable.❑ To turn on the TV speakers, set the Speaker option to On (see page 73).

Channels

<i>Problem</i>	<i>Possible Remedies</i>
Cannot receive upper channels (UHF) when using an antenna	<ul style="list-style-type: none">❑ Change the Cable option to Off (see page 76).❑ Use Auto Program in the Channel Menu to add receivable channels that are not presently in the TV's memory (see page 76).
TV is fixed to one channel	<ul style="list-style-type: none">❑ Use Auto Program in the Channel Menu to add receivable channels that are not presently in the TV's memory (see page 76).❑ Check your Channel Fix settings (see page 76).
Cannot receive any channels when using cable TV	<ul style="list-style-type: none">❑ Use Auto Program in the Channel Menu to add receivable channels that are not presently in the TV's memory (see page 76).❑ Check your cable settings.❑ Make sure the Cable option is set to On in the Channel Menu (see page 76).
Cannot receive or select channels	<ul style="list-style-type: none">❑ Use Auto Program in the Channel Menu to add receivable TV channels that are not presently in TV memory (see page 76).
Cannot receive digital channels (when a DTV receiver is connected)	<ul style="list-style-type: none">❑ Check the connections between the DTV receiver and the LCD projection TV (see page 39).❑ Check your local listings to find out if you can receive digital broadcasts in your area.

General

<i>Problem</i>	<i>Possible Remedies</i>
How to restore Video settings to factory settings	<ul style="list-style-type: none"> ❑ Press RESET on the remote control while in the Video Menu (see page 69).
How to restore Audio settings to factory settings	<ul style="list-style-type: none"> ❑ Press RESET on the remote control while in the Audio Menu (see page 72).
Cannot cycle through the other video equipment connected to the TV	<ul style="list-style-type: none"> ❑ Be sure the Video Label option is not set to Skip (see page 83).
Cannot operate Menu	<ul style="list-style-type: none"> ❑ If a menu option appears in gray, this indicates that the menu option is not available.
Lost password	<ul style="list-style-type: none"> ❑ In the password screen (see page 78), enter the following master password: 4357. The master password clears your previous password; it cannot be used to temporarily unblock channels.
LED on the display unit is lit	<ul style="list-style-type: none"> ❑ The POWER/STANDBY LED lights up when the TV is turned on. If the LED blinks continuously, this may indicate the TV needs a service. ❑ The TIMER LED indicates that the timer is set. When the timer is set, this LED will remain lit even when the LCD projection TV is turned off.
LCD projection TV is fixed to one channel	<ul style="list-style-type: none"> ❑ Use Auto Program in the Channel menu to add receivable channels that are not presently in TV memory (see page 76). ❑ Check your Channel Fix settings (see page 76).

Flashing Indicators on the Front of the Monitor

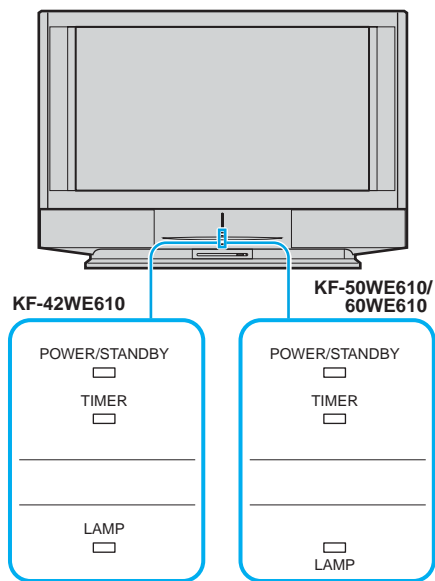

The POWER/STANDBY (red) and/or LAMP (red) indicators indicate the conditions of the LCD projection TV and warnings by lighting or flashing, as follows.

The POWER/STANDBY indicator flashes.

- ❑ The lamp for the light source is ready to turn on.

The POWER/STANDBY indicator flashes three times.

- ❑ The lamp cover is not attached securely. When you correct, the POWER/STANDBY indicator goes out and the LCD projection TV enters the standby mode (see page 16).

The LAMP indicator flashes.

- ❑ The lamp for the light source burns out. Replace it with new one (see page 13).

If the LCD projection TV is not recovered after correcting the problems, contact with qualified Sony personnel.

Specifications

Projection System	3 LCD Panels, 1 lens projection system	
LCD Panel	0.87 inch TFT LCD panel Approx. 3.28 million dots (1,092,168 pixels)	
Projection Lens	High Performance, large diameter hybrid lens F2.4	
Antenna	75 ohm external terminal for VHF/UHF	
Lamp	UHP lamp, 100W XL-2100U	
Television System	NTSC, American TV Standard	
Screen Size (measured diagonally)	KF-42WE610: 42 inches, KF-50WE610: 50 inches, KF-60WE610: 60 inches	
Channel Coverage		
VHF	2-13	
UHF	14-69	
CATV	1-125	
Power Requirements	120V, 60 Hz	
Number of Inputs/Outputs		
DVI-HDTV	1 terminal, 3.3 V T.M.D.S., 50 ohms The DVI-HDTV input terminal is compliant with the EIA-861 standard and is not intended for use with personal computers.	
Video (IN)	4	1 Vp-p, 75 ohms unbalanced, sync negative
S Video (IN)	4	Y: 1 Vp-p, 75 ohms unbalanced, sync negative C: 0.286 Vp-p (Burst signal), 75 ohms
Audio (IN)	6	500 mVrms (100% modulation) Impedance: 47 kilohms
AUDIO (VAR/FIX)	1	500 mVrms at the maximum volume setting (Variable) 500 mVrms (Fixed) Impedance (output): 2 kilohms
CONTROL S (IN/OUT)	1	minijacks
Component Video Input	2 (Y, P _B , P _R)	Y: 1.0 Vp-p, 75 ohms unbalanced, sync negative P _B : 0.7 Vp-p, 75 ohms P _R : 0.7 Vp-p, 75 ohms
RF Inputs	2	
Converter	1	
Speaker Output	5W (L), 5W (R), 20W (Woofer)	
Dimensions (W × H × D)	KF-42WE610: 1,201 × 819 × 371 mm (47 1/4 × 32 1/4 × 14 1/2 inches) KF-50WE610: 1,377 × 928 × 452 mm (54 1/4 × 36 1/2 × 17 3/4 inches) KF-60WE610: 1,619 × 1,067 × 541 mm (63 3/4 × 42 × 21 1/4 inches)	
Mass	KF-42WE610: 32 Kg (70 lb 12 oz) KF-50WE610: 39.5 kg (87 lb 1 oz), KF-60WE610: 49.5 kg (109 lb 2 oz)	
Power Consumption		
In Use	210 W	
In Standby	Under 1 W	

Other Information

Supplied Accessories	
Remote Control	RM-Y913
AA Batteries	2 supplied for remote control
Cleaning Cloth	1
Optional Accessories	
TV Stand	SU-GW1 (for KF-50/60WE610), SU-GW2 (for KF-42WE610)
Lamp	XL-2100U
AV Cable	VC-810S/820S/830S
Control S Cable	RK-G69
Component Video Cable	VMC-10/30
AV Receiver	STR series or equivalent
Memory Stick media	8MB (MSA-8A), 16MB (MSA-16A), 32MB (MSA-32A), 64MB (MSA-64A), 128MB (MSA-128A)

Design and specifications are subject to change without notice.

Index

- A**
- Activating a Twin View screen **50**
 - Adding channels to the channel list **76**
 - Adjusting audio, Steady Sound **72**
 - ANT button **45**
 - Antenna, connecting **25**
 - Audio menu **68, 72**
 - Audio receiver, connecting **36**
 - Audio/Video cable **24**
 - Auto Program (channel setup) **43, 76**
 - Auto Setup **43, 76**
- B**
- Balance, adjusting **72**
 - Bass, adjusting **72**
 - Batteries, inserting in remote **17**
 - Bilingual audio **72**
 - BN Smoother **71**
 - Brightness, adjusting **69**
- C**
- Cable
 - connecting **25–28**
 - setting ON/OFF **76**
 - with VCR, connecting **29**
 - Cable box
 - connecting with VCR **30**
 - using with TV remote control **89**
 - Camcorder, connecting **41**
 - Caption Vision **82**
 - CATV. See Cable.
 - Channel list, adding channels **76**
 - Channel menu **68, 76**
 - Channel Skip/Add **77**
 - Channels
 - Auto Program **76**
 - creating labels **77**
 - setting up **43**
 - Cleaning Cloth **12**
 - Closed caption modes **82**
 - CODE SET button **86**
 - Color temperature, adjusting **70**
 - Color, adjusting **69**
 - Connecting
 - Audio receiver **36**
 - Cable box **26–28, 30–31**
 - Cable or an Antenna **25**
 - Cable or Antenna **25**
 - Camcorder **41**
 - Digital TV Receiver **39**
 - DVD player **37, 38**
 - Satellite receiver **33–35**
 - VCR **30–32, 34**
 - Connector Types **24**
 - Contents of box **17**
 - CONTROL S **42**
- D**
- Digital TV
 - connecting **39**
 - watching **48**
 - Digital TV program **48**
 - Digital TV receiver, connecting **39**
 - DISPLAY button **45**
 - Display, turning off **45**
 - DRC Mode **70**
 - DVD player
 - using with TV remote control **88**
 - with A/V connectors, connecting **38**
 - with component video connectors, connecting **37**
- E**
- Enlarging pictures, in Twin View **52**
- F**
- Favorite Channel
 - setting up **76**
 - using **49**
 - FAVORITES button **44**
 - Features **9**
 - FREEZE button **44**
 - Freeze, using **46, 53**
 - FUNCTION button **44**
- H**
- High Altitude **85**
 - Hue, adjusting **69**
- I**
- Image Setup Menu **62**

Image Shift **85**
Inputs, labeling **83**
Installation of the projection TV **25–42**

J

JUMP button **44**
Jump, using **46**

L

Label
 Channels **77**
 video inputs **83**
Lamp, replacing **13–16**

M

Memory Stick
 Advance **65**
 Audio Select **65**
 Close **61, 65**
 Delete **61, 63, 65**
 Digi. Cam. Mode **66**
 File **66**
 Full Screen **61**
 Home Menu **65**
 Index Menu **60**
 Information **63, 65**
 inserting **57**
 Interval **65**
 Memory Stick Home **58**
 Movie Player **61**
 Playing Movies **63**
 Protect **61, 63, 65**
 Return **63**
 Rotate **61, 63**
 Slide Show **61**
 Start **65**
 Still Images **62**
MEMORY STICK button **45**

MENU button **45**

Menus

 Audio **68, 72**
 Channel **68, 76**
 Parent **68, 78**
 Screen **68, 74**
 Setup **68, 82**
 Video **68, 69**

Mild Mode **70**

MODE

 Pro **47**
 Standard **47**
 Vivid **47**

MTS/SAP button **45**
MTS/SAP, using **47**
Muting, using **46**

N

NR **70**

P

Palette **71**
Password, changing **79**
Picture contrast, adjusting **69**
PICTURE MODE button **44**
Picture size, adjusting in Twin View **52**
Playing Movies **63**
POWER buttons (GREEN) **45**
POWER/STANDBY **98**
Presetting channels **43**
Problems, troubleshooting **92, 97**

R

Ratings

 setting **80**
 viewing blocked programs **79**

Remote control

 Function of buttons **46**
 inserting batteries **17**
 programming **86–87**

Remote control, operating other components with

 Cable box **89**
 DVD player **88**
 Satellite receiver **89**
 VCR **88**

Removing channels from the channel list **77**

RESET button **45**

Resetting

 Audio options **72**
 Video options **69**

S

S Video cable **24**

Satellite receiver

 connecting **33**
 using with TV remote control **89**

Screen menu **74**

Setting up channels **43**

Setup menu **68, 82**

Sharpness, adjusting **69**

Sleep **84**

Specifications **99–100**

(Continued)

Steady Sound
adjusting **72**
Still Images **62**
Surround sound **72**

T

Timer
set current **84**
Timer menu **84**
Timer setting **84**
Treble, adjusting **72**
Troubleshooting **92, 97**
TV/VIDEO button **45**
Twin View™
activating a picture **50**
using **50**

V

VCR
using with TV remote control **88**
with cable box, connecting **30**
with cable, connecting **29**
with satellite receiver, connecting **34**
Video inputs, labeling **83**
Video menu **68, 69**
Video Modes, selecting **69**
Viewing area, recommended **20**
VOL +/- button **44**

W

WIDE MODE button **44**

Z

Zoom feature, with Twin View **52**

If, after reading this instruction manual, you have additional questions related to the use of your Sony projection TV, please call one of the following numbers (English only).

Customers in the continental United States

contact the Direct Response Center at:

1-800-222-SONY (7669)

Customers in Canada contact the

Customer Relations Center at:

(416) 499-SONY (7669)

<http://www.sony.net/>

Printed in U.S.A.